

# Melec



2-phase/5-phase Stepping Motor Driver

## QDB-M240X2

### Instructions Manual

(For designers' use)

# USER'S MANUAL

Please ensure to read and understand this Instructions Manual before using the product. Please keep this Instructions Manual at hand so that it is always available for reference.

CE

MN0370

## **Introduction**

This Instructions Manual describes the safe and proper method of handling "2-phase/5-phase Stepping Motor Driver QDB-M240X2" with emphasis on the specifications, assuming that our readers are engaged in designing of control devices incorporating stepping motors.

Please ensure to read and understand this Instructions Manual before using the product.

Please keep this Instructions Manual at hand so that it is always available for reference.

**Descriptions in this manual on safety matters:**

This product must be operated and used properly.

Otherwise, or when it is operated and used erroneously, unforeseen accidents may occur, causing physical injuries or property damages.

Majority of these accidents can be avoided if you are well informed of hazardous circumstances in advance.

Consequently, this instructions manual describes all the hazardous and dangerous circumstances and situations which can be foreseen and anticipated as well as necessary precautions.

All the above descriptions are being titled by the following symbol-marks and signal-words, namely:



Represents warnings ignorance of which can cause accidents involving fatal or serious physical injuries.



Represents cautions ignorance of which can cause accidents involving minor physical injuries or property damages.

## Introduction

Descriptions in this manual on safety matters:

	CONTENTS	PAGE
<b>1. Safety</b>		
1-1. Safety precautions .....		6
1-2. Safety Information for Handling .....		7
<b>2. Overview</b>		
2-1. Characteristics .....		10
2-2. Product Configuration .....		10
2-3. Appearance .....		10
<b>3. Name and Function of Each Section</b>		
3-1. Signal I/O Connector (J1) .....		11
3-2. DC Input/Motor Output Connector (J2, J3, J4) .....		12
3-3. POWER LED .....		12
3-4. ALM LED .....		12
3-5. Operating Section .....		13
<b>4. Setting</b>		
4-1. Setting MOTOR SELECT switch .....		14
4-2. Setting STEP ANGLE SELECT switch .....		15
4-3. Setting HOLD CURRENT SELECT switch .....		16
4-4. Setting DRIVE CURRENT SELECT switch .....		17
4-5. Setting PULSE INPUT TYPE SELECT switch .....		18
4-6. Setting EXTEND FUNCTION SELECT switch .....		19
<b>5. Installation</b>		
5-1. Conditions for Installation .....		20
5-2. Mounting Method .....		21
<b>6. Connection</b>		
6-1. Overview of Connection Configuration .....		22
6-2. Connecting Signal I/O Connector (J1) .....		23
6-3. Connecting DC Input/Motor Output Connector (J2, J3, J4) .....		24
6-4. Inputting Power .....		27
<b>7. Confirmation of Setting and Connection</b>		
7-1. Check Points .....		28

	PAGE
<b>8. Maintenance and Check-up</b>	
8-1. Maintenance and Check-up .....	29
8-2. Troubleshooting .....	29
<b>9. Storing and Disposal</b>	
9-1. Storing .....	31
9-2. Disposal .....	31
<b>10. Specifications</b>	
10-1. General Specifications .....	32
10-2. I/O Signal	
(1) Example Circuit Connection .....	33
(2) Drive pulse input           (1/CW, 1/CCW, 2/CW, 2/CCW) .....	34
(3) Extend function signal input   (IN1, IN2) .....	35
10-3. Alarm (ALM) LED .....	36
10-4. Dimensions .....	37
10-5. Applicable Motors .....	38
10-6. Torque Characteristics .....	41
10-7. Conforming to Europe standards .....	48

The main parts which revised by this manual

## 1. Safety

### 1 – 1. Safety Precautions

 <b>WARNING</b>
--

- (1) This product is not designed or manufactured for application for equipment requiring high level of reliability such as equipment related to nuclear energy, aeronautics-related equipment, automobiles, ships, medical appliances directly handling the human body and equipment that might seriously affect properties.
- (2) Do not use or keep the product in explosive or corrosive environments, in the presence of flammable gases, locations subjected to splashing water, fine particles, soot, steam, or exposed to radiation or direct sunshine. Doing so may cause injury or fire.
- (3) For the driver's power supply, use a DC power supply with reinforced insulation on its primary and secondary sides. Failure to do so may cause electric shock.
- (4) This product is designed for use within machinery, so it should be installed within an enclosure. Failure to do so may cause injury.
- (5) Do not transport, move, install the product, perform connections or inspections when the power is on. Doing so may cause electric shock, injury or fire.
- (6) Only qualified personnel are allowed to transport, move, install the product, perform connections or inspections. Failure to do so may cause injury or fire.

 <b>CAUTION</b>
--

- (7) Do not touch the driver during operation or immediately after stopping. Doing so may cause burn on the skin due to overheating of the driver.
- (8) Ensure to use this product according to the method specified in the Instructions Manual and within the specifications.
- (9) Depending on the operational conditions, the stepping motor may step out when it is on holding-state or driving-state. In particular, the load in transport may fall if the motor steps out on the vertical drive (such as the Z-axis). Start operation after test run for deliberate confirmation of operation.
- (10) Provide fail-safe measures so that the entire system may operate in a safe mode even in cases of the external power supply failure, disconnection of the signal line, or any failure on the driver.

## 1 – 2. Safety Information for Handling

## ●Overall:

 CAUTION

Do not touch the driver during operation or immediately after stopping. It may cause burn on the skin due to overheating of the driver.

●When setting up the MOTOR SELECT switch/  
the STEP ANGLE SELECT switch: CAUTION

Erroneous setting may cause breakage of the machine or injury due to unexpected rotation of the motor. Ensure correct setting.

## ●When setting up the HOLD CURRENT SELECT switch:

 CAUTION

A high setting value may cause burn on the skin due to overheating of the motor. Do not select a high value beyond the required.

## ●When setting up the DRIVE CURRENT SELECT switch:

 CAUTION

Erroneous setting may cause motor deterioration or damage and burn on the skin due to overheating of the motor. Ensure correct setting.

## ●When setting up the PULSE INPUT TYPE SELECT switch:

 CAUTION

Erroneous setting may cause breakage of the machine or injury due to unexpected rotation of the motor. Ensure correct setting.

- When setting up the EXTEND FUNCTION SELECT switch:

**⚠ CAUTION**

Erroneous setting may cause breakage of the machine or injury due to unexpected rotation of the motor.  
Ensure correct setting.

- When installing:

**⚠ WARNING**

Overheating may cause fire.  
Mount it on a noncombustible member.  
Keep it away from combustibles.

- When connecting the DC Input/ Motor Output Connectors (J2, J3, J4):

**⚠ CAUTION**

Erroneous connection may cause breakage of the motor or the driver.  
Correctly connect the DC Input/Motor output connector.

- When inputting power:

**⚠ CAUTION**

Breakage of the machine or injury is apprehended due to unexpected behavior of the motor. Maintain the state where emergency stop is enabled at any time.

- When inputting the motor excitation stop (M.F) signal:

**⚠ WARNING**

Deterioration of the holding power with the motor may cause breakage of the machine or injury.  
Check safety before inputting.



- When alarm (ALM) LED comes on:

** WARNING**

Overheating may cause fire.  
Stop operation when this LED comes on.

- When the alarm (ALM) LED flashes:

** CAUTION**

Breakage of the machine or injury is apprehended due to unexpected behavior of the motor.  
Stop operation when this LED flashes.

- When performing maintenance and checking:

** WARNING**

Injury or fire is apprehended due to unexpected behavior.  
Do not replace fuse.  
Do not disassemble, repair or modify.

## 2. Overview

### 2-1. Characteristics

QDB-M240X2 is a driver for two 2-phase/5-phase stepping motors with DC +24V input. Driving method is the bipolar constant current type.

It can drive the 5-phase stepping motor of new pentagon connection ranging from 0.35A/phase to 2.40A/phase, and the 2-phase stepping motor of bipolar winding ranging from 0.35A/phase to 2.40A/phase.

Step angles can be selected from sixteen step angles ranging from 1 division to 500 division of the basic angle.

HOLD CURRENT and DRIVE CURRENT can be set up.

### 2-2. Product Configuration

● QDB-M240X2

One unit (main frame)

J1, J2, J3 and J4 of the housing and the contact is not in accessories.

### 2-3. Appearance

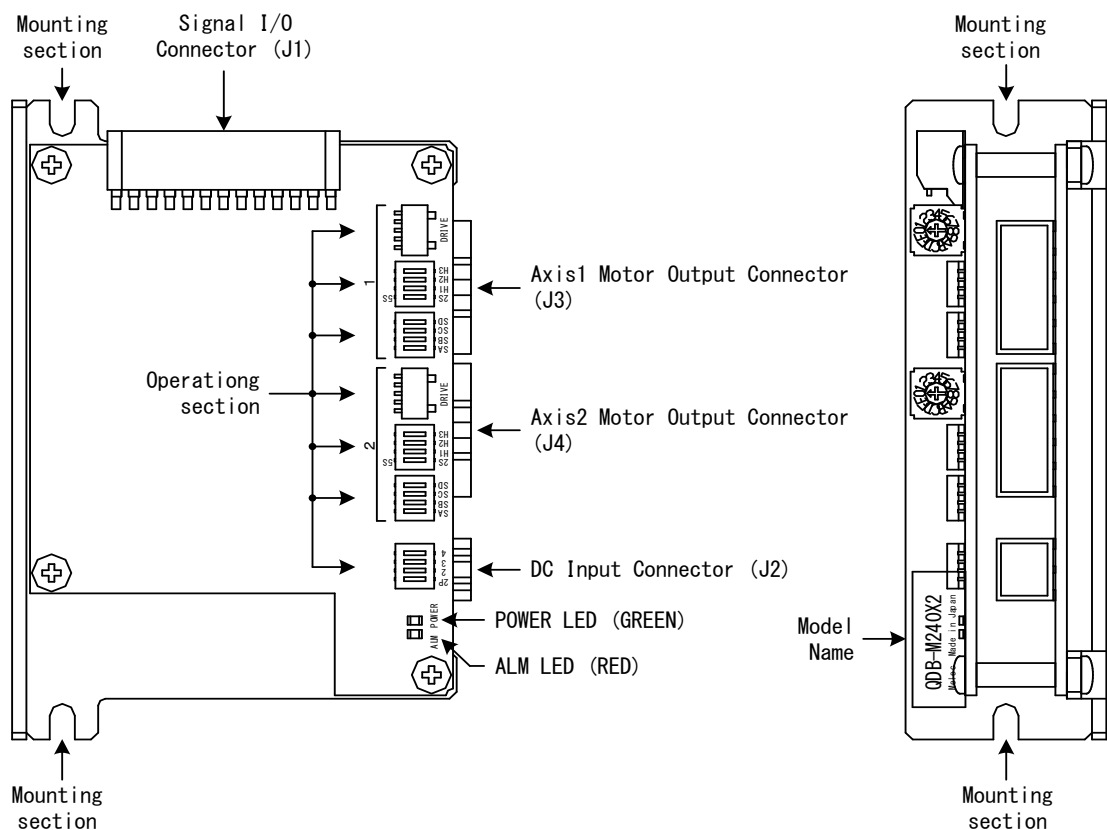

### 3. Name and Function of Each Section

#### 3-1. Signal I/O Connector (J1)

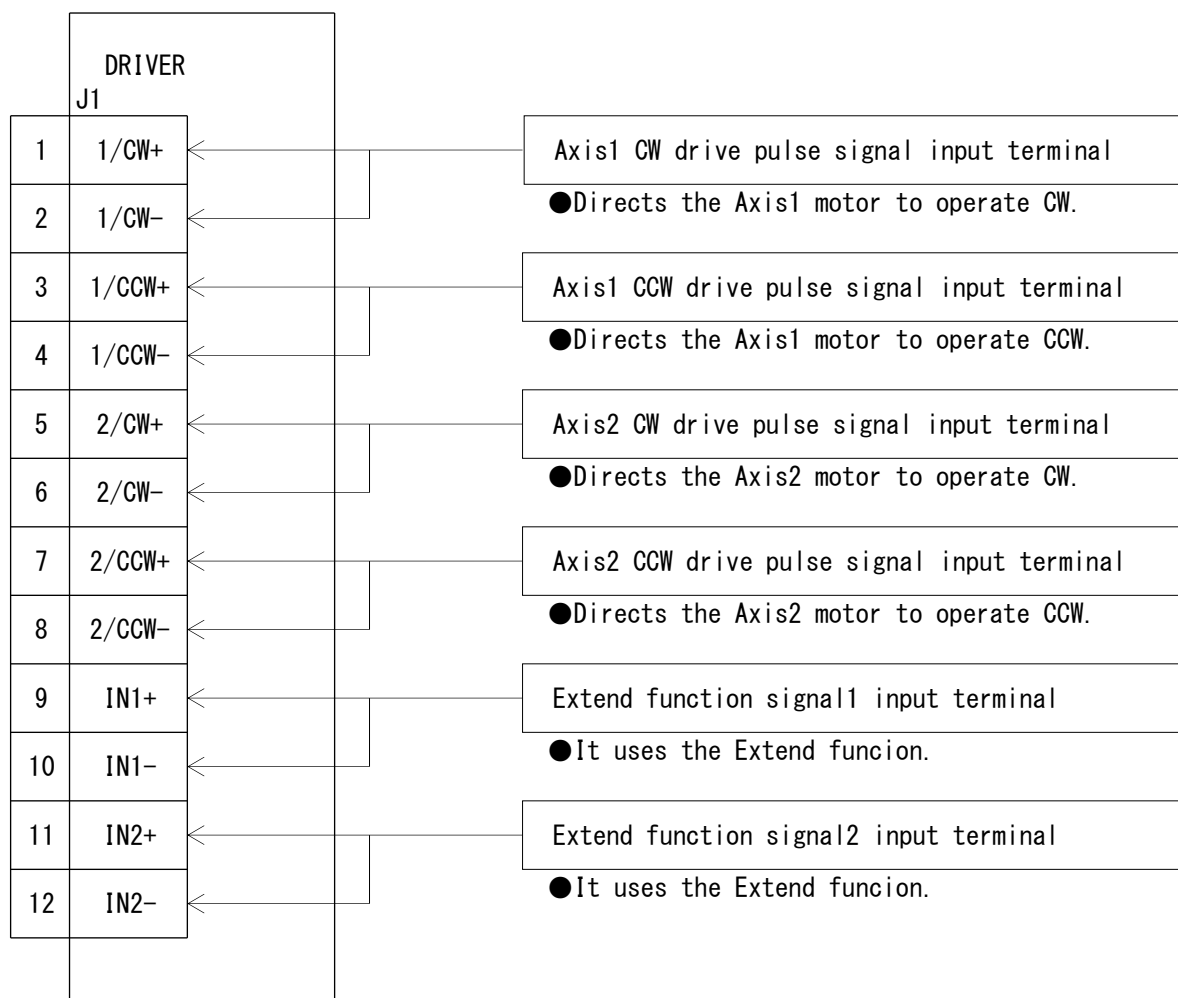

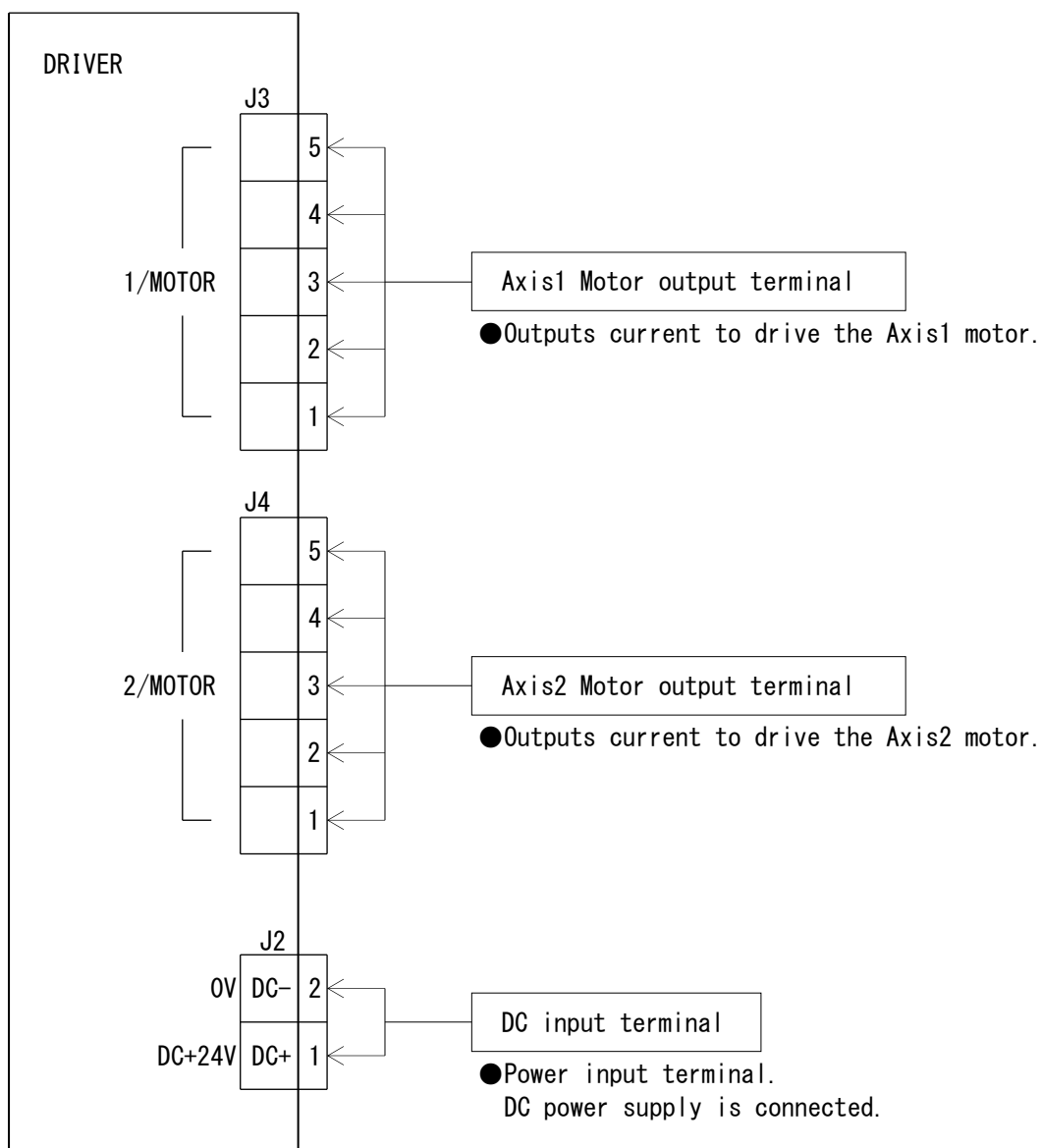
**3 – 2. DC Input/Motor Output Connector ( J 2, J 3, J 4 )****3 – 3. POWER LED**

(1) POWER LED (GREEN) comes on upon inputting power.

**3 – 4. ALM LED**

(1) When an alarm occurs, ALM LED (RED) comes on or flashes.

3 – 5. Operating Section

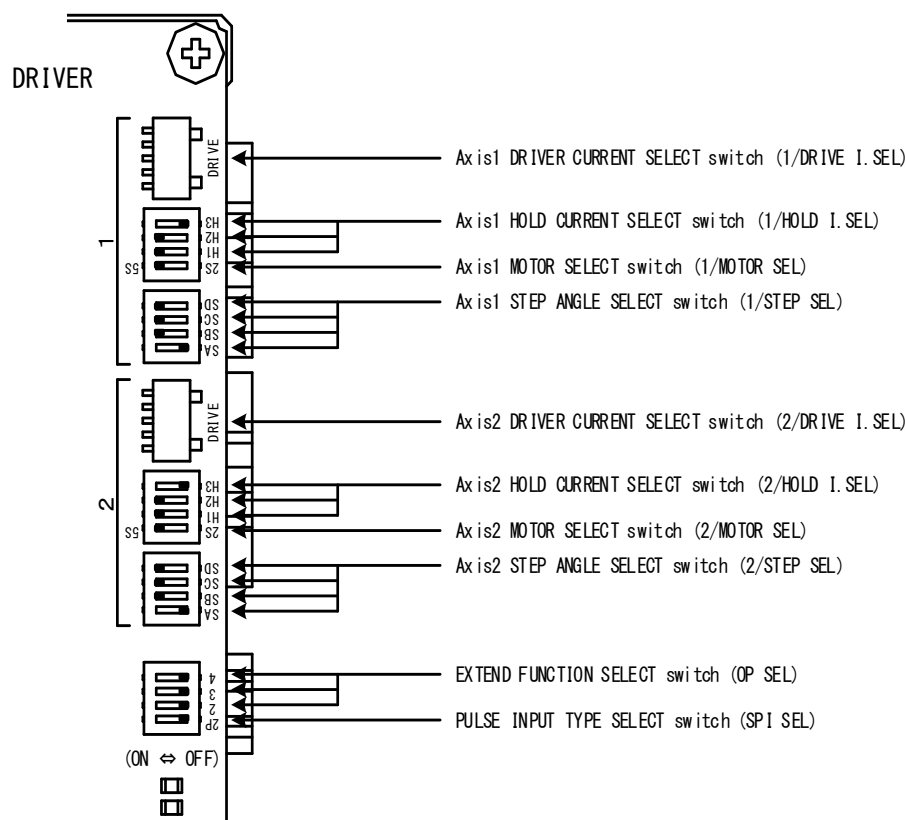

Name of Operating Section	Function	Factory Setting
Axis1 DRIVE CURRENT SELECT switch	Select Axis1 DRIVE CURRENT.	[No. 4]
4: Axis1 HOLD CURRENT SELECT switch	Select Axis1 HOLD CURRENT.	H3 : [OFF]
3: Axis1 HOLD CURRENT SELECT switch		H2 : [ON]
2: Axis1 HOLD CURRENT SELECT switch		H1 : [ON]
1: Axis1 MOTOR SELECT switch	Select Axis1 2-phase MOTOR or 5-phase MOTOR.	2S/5S : [ON]
4: Axis1 STEP ANGLE SELECT switch	Select Axis1 STEP ANGLE.	SD : [ON]
3: Axis1 STEP ANGLE SELECT switch		SC : [ON]
2: Axis1 STEP ANGLE SELECT switch		SB : [ON]
1: Axis1 STEP ANGLE SELECT switch		SA : [OFF]
Axis2 DRIVE CURRENT SELECT switch	Select Axis2 DRIVE CURRENT.	[No. 4]
4: Axis2 HOLD CURRENT SELECT switch	Select Axis2 HOLD CURRENT.	H3 : [OFF]
3: Axis2 HOLD CURRENT SELECT switch		H2 : [ON]
2: Axis2 HOLD CURRENT SELECT switch		H1 : [ON]
1: Axis2 MOTOR SELECT switch	Select Axis2 2-phase MOTOR or 5-phase MOTOR.	2S/5S : [ON]
4: Axis2 STEP ANGLE SELECT switch	Select Axis2 STEP ANGLE.	SD : [ON]
3: Axis2 STEP ANGLE SELECT switch		SC : [ON]
2: Axis2 STEP ANGLE SELECT switch		SB : [ON]
1: Axis2 STEP ANGLE SELECT switch		SA : [OFF]
4: EXTEND FUNCTION SELECT switch	Select EXTEND FUNCTION.	4 : [OFF]
3: EXTEND FUNCTION SELECT switch		3 : [OFF]
2: EXTEND FUNCTION SELECT switch		2 : [OFF]
1: PULSE INPUT TYPE SELECT switch		2P : [OFF]

## 4. Setting

### 4 – 1. Setting MOTOR SELECT switch

 **CAUTION**

Erroneous setting may cause breakage of the machine or injury due to unexpected rotation of the motor.  
Ensure correct setting.

The motor of Axis1 is set up with the 1/MOTOR SEL switch.  
The motor of Axis2 is set up with the 2/MOTOR SEL switch.  
MOTOR SEL can be selected 2-phase motor or 5-phase motor.  
Set this switch with power OFF.

- (1) Turn power [OFF].
- (2) Set the 1/MOTOR SEL switch.
- (3) Set the 2/MOTOR SEL switch.

MOTOR SEL	Motor
ON	5-phase stepping motor of new pentagon connection (5S)
OFF	2-phase stepping motor of bipolar winding (2S)

(Factory Setting)

## 4 – 2. Setting STEP ANGLE SELECT switch

**CAUTION**

Erroneous setting may cause breakage of the machine or injury due to unexpected rotation of the motor.  
Ensure correct setting.

The step angle of Axis1 is set up with the 1/STEP SEL switch.  
The step angle of Axis2 is set up with the 2/STEP SEL switch.  
The step angle can be selected from sixteen different types of step angles.  
Set this switch with power OFF.

- (1) Turn power [OFF].
- (2) Set the step angle of Axis1 required by 1/STEP SEL switch.
- (2) Set the step angle of Axis2 required by 2/STEP SEL switch.

● Relationship between the MOTOR SEL switch, the STEP SEL switch and the step angle.

MOTOR SEL [ON : 5-phase motor (5S) ]						
STEP SEL				1/ Divisions	step angle(° )	
SD	SC	SB	SA		0.72° motor	
ON	ON	ON	ON	1/1	0.72	
ON	ON	ON	OFF	1/2	0.36 (Factory Setting)	
ON	ON	OFF	ON	1/4	0.18	
ON	ON	OFF	OFF	1/10	0.072	
ON	OFF	ON	ON	1/20	0.036	
ON	OFF	ON	OFF	1/40	0.018	
ON	OFF	OFF	ON	1/100	0.0072	
ON	OFF	OFF	OFF	1/200	0.0036	
OFF	ON	ON	ON	—	—	
OFF	ON	ON	OFF	—	—	
OFF	ON	OFF	ON	—	—	
OFF	ON	OFF	OFF	—	—	
OFF	OFF	ON	ON	—	—	
OFF	OFF	ON	OFF	—	—	
OFF	OFF	OFF	ON	—	—	
OFF	OFF	OFF	OFF	—	—	

MOTOR SEL [OFF : 2-phase motor (2S) ]						
STEP SEL				1/ Divisions	step angle(° )	
SD	SC	SB	SA		1.8° motor	
ON	ON	ON	ON	1/2.5	0.72	
ON	ON	ON	OFF	1/5	0.36	
ON	ON	OFF	ON	1/10	0.18	
ON	ON	OFF	OFF	1/25	0.072	
ON	OFF	ON	ON	1/50	0.036	
ON	OFF	ON	OFF	1/100	0.018	
ON	OFF	OFF	ON	1/250	0.0072	
ON	OFF	OFF	OFF	1/500	0.0036	
OFF	ON	ON	ON	1/1	1.8	
OFF	ON	ON	OFF	1/2	0.9	
OFF	ON	OFF	ON	1/4	0.45	
OFF	ON	OFF	OFF	1/8	0.225	
OFF	OFF	ON	ON	1/16	0.1125	
OFF	OFF	ON	OFF	1/32	0.05625	
OFF	OFF	OFF	ON	1/64	0.028125	
OFF	OFF	OFF	OFF	1/128	0.0140625	

## 4 – 3. Setting HOLD CURRENT SELECT switch

**⚠ CAUTION**

A high setting value may cause burn on the skin due to overheating of the motor. Do not select a high value beyond the required.

The HOLD CURRENT of Axis1 is set up with the 1/HOLD I. SEL switch.  
 The HOLD CURRENT of Axis2 is set up with the 2/HOLD I. SEL switch.  
 The ratio of HOLD CURRENT to DRIVE CURRENT can be selected.

- (1) Set the HOLD I. SEL switch to the ratio of HOLD CURRENT to DRIVE CURRENT required.

●Ratio of HOLD CURRENT

$$\text{Ratio of HOLD CURRENT (\%)} = \frac{\text{HOLD CURRENT}}{\text{DRIVE CURRENT}} \times 100$$

HOLD I. SEL switch			Ratio of HOLD CURRENT (%)
H3	H2	H1	
OFF	OFF	OFF	10
OFF	OFF	ON	20
OFF	ON	OFF	30
OFF	ON	ON	40
ON	OFF	OFF	50
ON	OFF	ON	60
ON	ON	OFF	70
ON	ON	ON	100

(Factory Setting)

- HOLD CURRENT changes relative to DRIVE CURRENT setting.  
 The ratio of HOLD CURRENT [100%] represents the same as the setting for DRIVE CURRENT.
- The greater the ratio of HOLD CURRENT grows, the more heat the motor generates when is on holding-state.



## 4 – 4. Setting DRIVE CURRENT SELECT switch

**CAUTION**

Erroneous setting may cause motor deterioration or damage and burn on the skin due to overheating of the motor. Ensure correct setting.

The DRIVE CURRENT of Axis1 is set up with the 1/DRIVE I.SEL switch.

The DRIVE CURRENT of Axis2 is set up with the 2/DRIVE I.SEL switch.

(1) Set the 1/DRIVE I.SEL switch No.

(2) Set the 2/DRIVE I.SEL switch No.

●Relationship between the DRIVE I.SEL switch No. and DRIVE CURRENT.

DRIVE I.SEL No.	A/phase
0	0.20
1	0.35
2	0.50
3	0.60
4	0.75
5	1.00
6	1.20
7	1.40
8	1.50
9	1.70
A	1.80
B	2.00
C	2.20
D	2.30
E	2.40
F	–

(Factory setting)

## 4 – 5. Setting PULSE INPUT TYPE SELECT switch

**CAUTION**

Erroneous setting may cause breakage of the machine or injury due to unexpected rotation of the motor.  
Ensure correct setting.

The pulse input method is set up with the SPI SEL switch.  
The setting is common in Axis1 and Axis2.  
Set this switch with power OFF.

- (1) Turn power [OFF].
- (2) Set the SPI SEL switch.

SPI SEL	Input type
ON	1 PULSE (1P)
OFF	2 PULSE (2P)

(Factory setting)

- When the motor is operated with two pulse signal inputs of CW and CCW, set the SPI SEL switch to [OFF(2P)].
- When the motor is operated with the pulse signal and direction signal input, set the SPI SEL switch to [ON(1P)].
- In the case that 1-pulse input method is selected, the CCW terminal becomes direction signal input designating the direction of the motor rotation. Drive pulse set to the CW terminal (CW+, CW-).

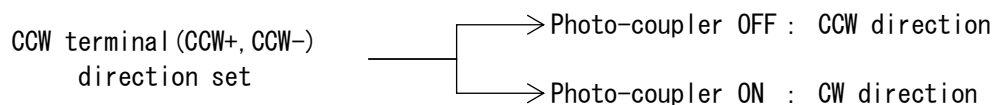

- The input timing is same with 2-pulse input method and 1-pulse input method. As for input timing, refer to "10-2. (2) Drive pulse input (CW, CCW)"

## 4 – 6. Setting EXTEND FUNCTION SELECT switch

**⚠ CAUTION**

Erroneous setting may cause breakage of the machine or injury due to unexpected rotation of the motor.  
Ensure correct setting.

Set this switch with power OFF.

- (1) Turn power [OFF].
- (2) Set the function required by the OP SEL switch.

OP SEL switch			Function
4	3	2	
OFF	OFF	OFF	Motor excitation stop input (M.F)
OFF	OFF	ON	–
OFF	ON	OFF	–
OFF	ON	ON	–
ON	OFF	OFF	Sub adjustment (Not available)
ON	OFF	ON	–
ON	ON	OFF	–
ON	ON	ON	–

(Factory Setting)

## 5. Installation

### 5-1. Conditions for Installation

**⚠ WARNING**

Overheating may cause fire.  
Mount it on a noncombustible member.  
Keep it away from combustibles.

- (1) Designed for incorporating into equipment used indoors, this product requires to be installed in the following environment:
- Indoors (where it is not exposed to direct sun).
  - Where ambient temperature and humidity are controlled within the range set out in the specifications.
  - Where there is no explosive, corrosive or inflammable gas.
  - Where it can be protected from dust, salt or iron powder.
  - Where the product main frame is not exposed to direct vibration or shock.
  - Where it is not exposed to splashes of water, oil or chemicals.
- (2) Install the driver at least 5mm away from other equipment.  
However, please be installed to a distance of at least 15mm from the heating element.

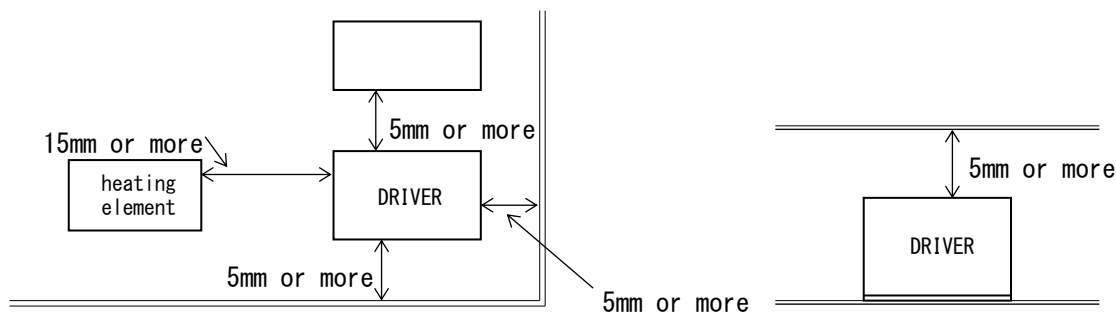

- Please contact us if you are not installed to a distance of at least 15mm from the heating element.
- (3) Take measures against accumulation of heat such as allowing generous space around the driver or installing a fan so that heat release is taken care of.
- (4) In the case that the alarm(ALM) LED comes on, perform compulsion air cooling and use the driver on the condition that the alarm(ALM) LED goes out.
- (5) Do not allow standing or placing anything heavy on the product.

## 5 – 2. Mounting Method

The round holes on the main frame are used.

The following items are required:

- M-3 screw (8mm or more in length): ----- 2
- M-3 spring washer: ----- 2
- M-3 flat washer: ----- 2

(1) Fix the product at the two round holes on the main frame.

● Mounting example

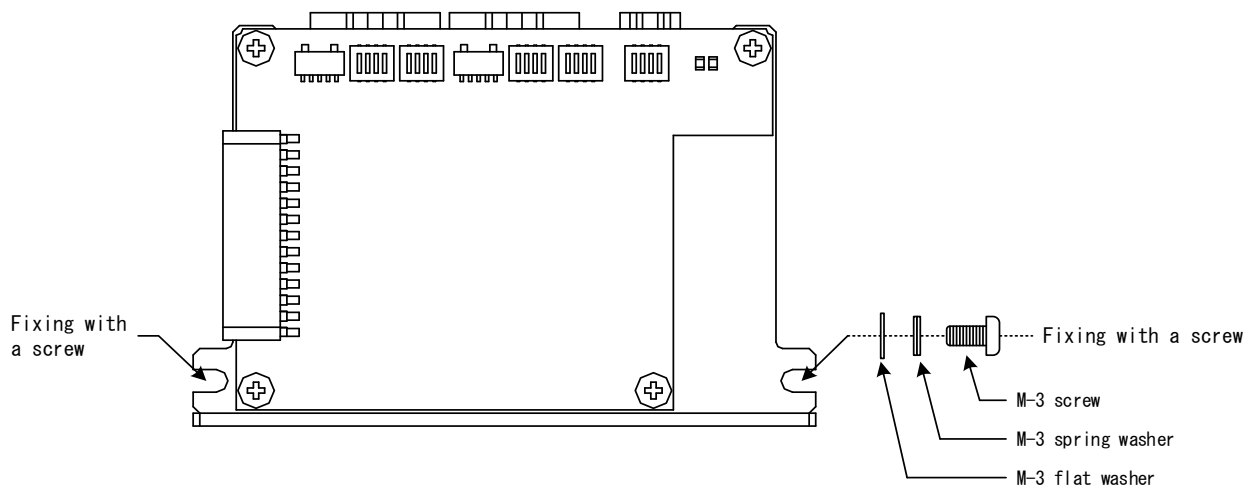
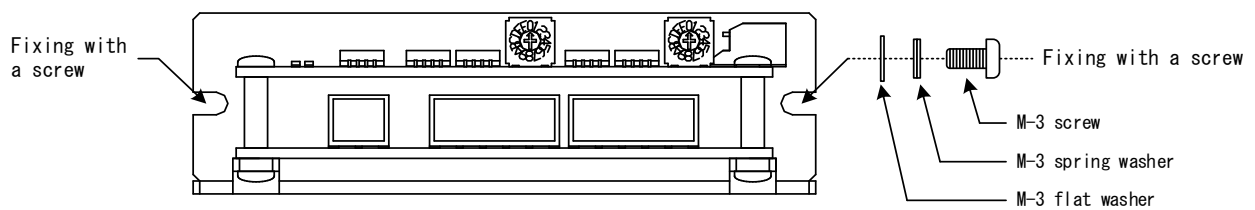

## 6. Connection

### 6 – 1. Overview of Connection Configuration

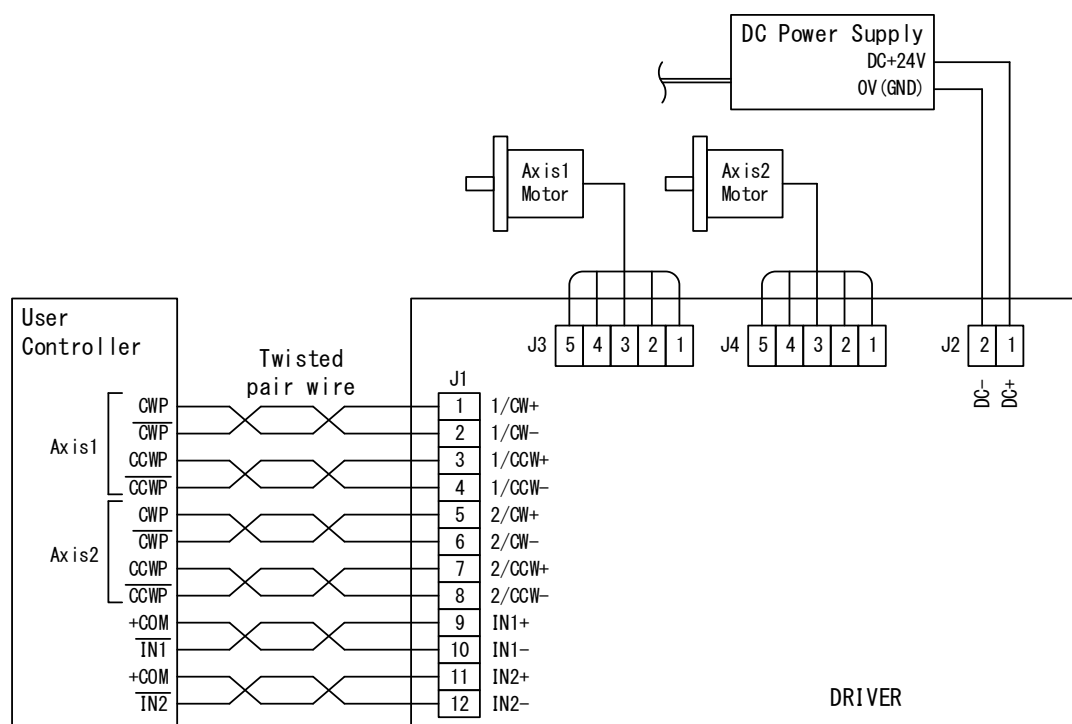

- Connect only one motor to one motor output terminal.
- Use twisted pair wire for the CW/CCW input signal line.
- Provide shielding for the signal line where considerable noise is generated.
- Use the wire material of the characteristic that is difficult to burn.
- For the driver's power supply, use a DC power supply with reinforced insulation on its primary and secondary sides.
- Connect the motor with power off.

## 6 – 2. Connecting Signal I/O Connector ( J 1 )

The following items are required:

- Housing for J1 (51103–1200:Molex) One unit
- Contact for J1 (50351–8100:Molex) 12 contacts
- Manually operated crimping tool for AWG28–22 (57295–5000:Molex) One unit

- (1) Crimp the contact to the cable used for wiring.
- (2) Insert the contact into the housing.  
Make sure that the housing No. and the connector No. on the main frame are matched before inserting the contacts.
- (3) Connect the housings to the connectors on the main frame.
  - The contacts for J1 are 12 pieces.
  - When inserting, keep pushing J1 housing into the connectors until it is locked. Also, check if the contacts are not displaced from the housing.
  - In wiring, isolate the J1 signal lines from equipment that may be a source of noise, the power line and the motor line.

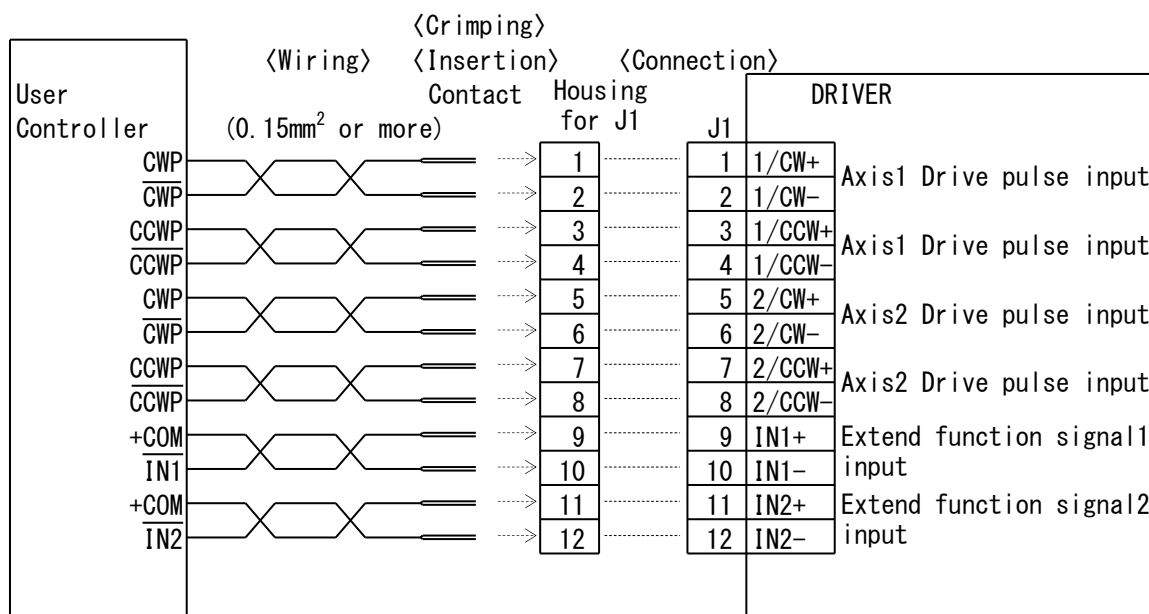
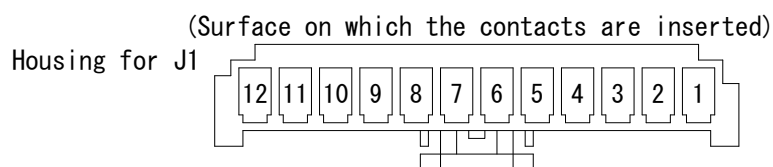

## 6-3. Connecting DC Input/Motor Output Connector (J2, J3, J4)

**CAUTION**

Erroneous connection may cause breakage of the motor or the driver. Correctly connect the DC Input/Motor output connector.

The following items are required:

●Housing for J2 (51067-0200:Molex)	One unit
●Housing for J3, J4 (51067-0500:Molex)	Two units
●Contact for J2, J3, J4 (50217-9101:Molex)	12 contacts
●Manually operated crimping tool for AWG24-18 (57189-5000:Molex)	One unit

- (1) Crimp the contact to the cable used for wiring.
- (2) Insert the contact into the housing.  
Make sure that the housing No. and the connector No. on the main frame are matched before inserting the contacts.
- (3) Connect the housings to the connectors on the main frame.
  - The contacts for J2(for DC input) are 2 pieces, and for J3 and J4(motor output) are 5 pieces.
  - When inserting, keep pushing J2, J3, J4 housings into the connectors until it is locked. Also, check if the contacts are not displaced from the housing.

(Surface on which the contacts are inserted)

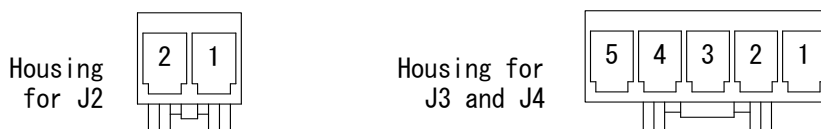

[DC input Connector]

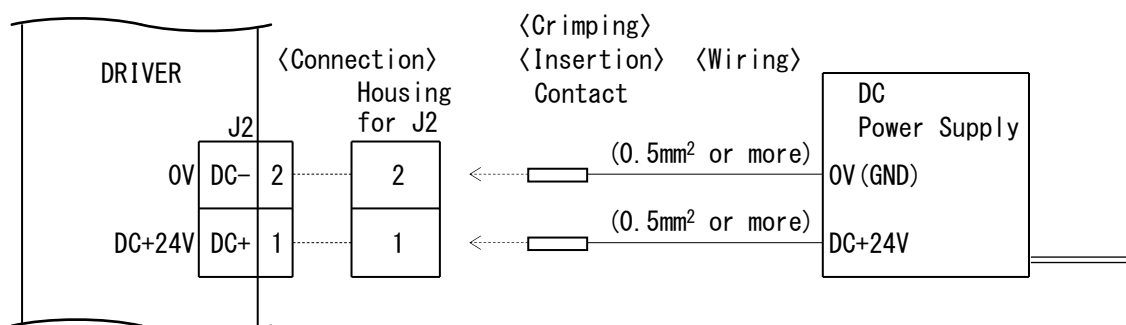



[Motor output Connector]

5-phase motor  
new pentagon connection

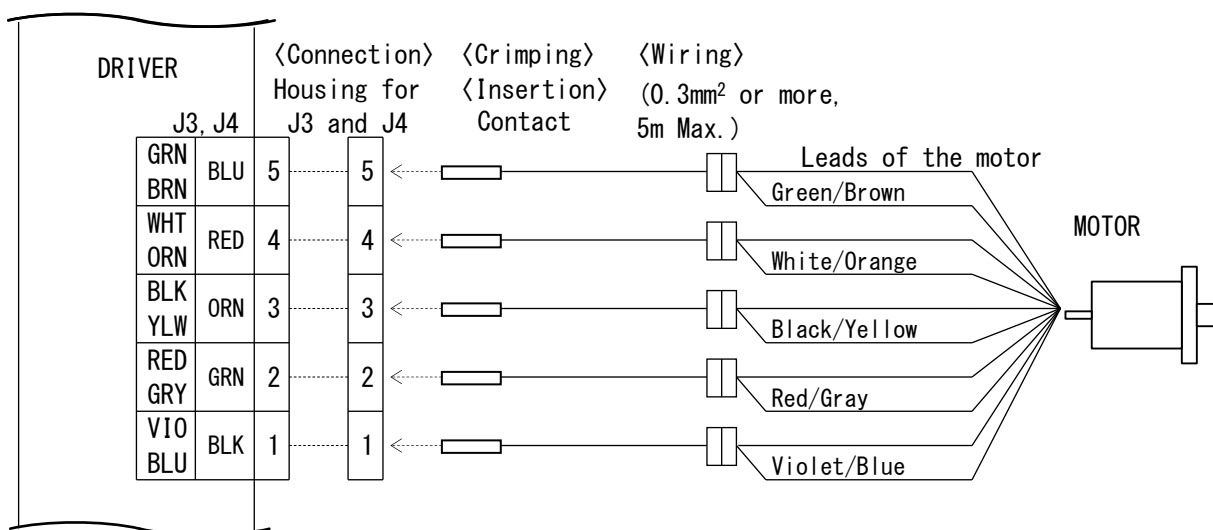
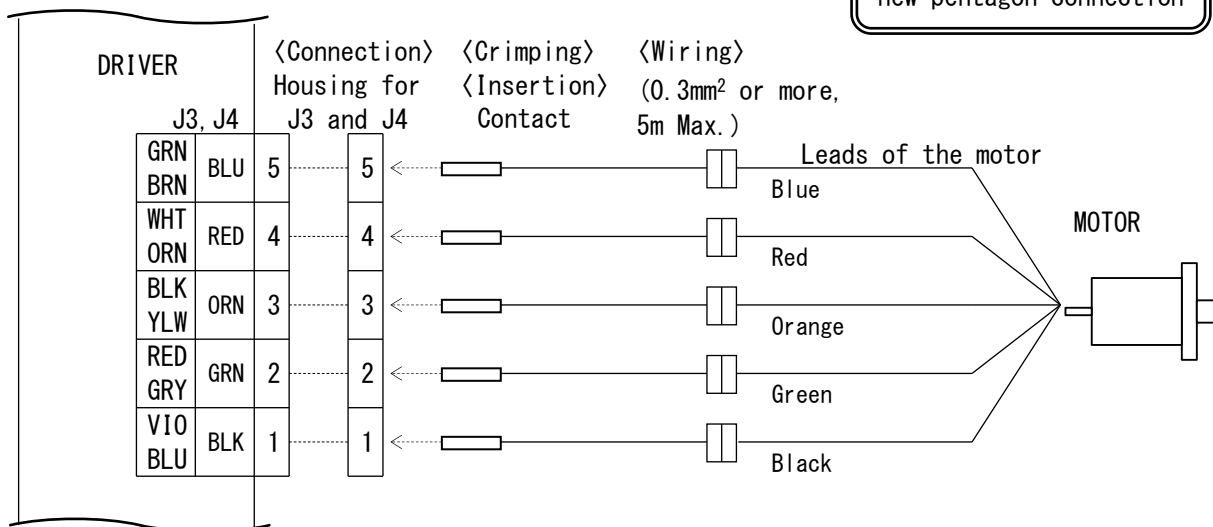

- Color indications for the motor crimping J3 and J4 represent colors of the leads of the motor.
- Use a cable of 5m or less for the motor cable.
- Connect the motor with power off.

## [Motor output Connector]

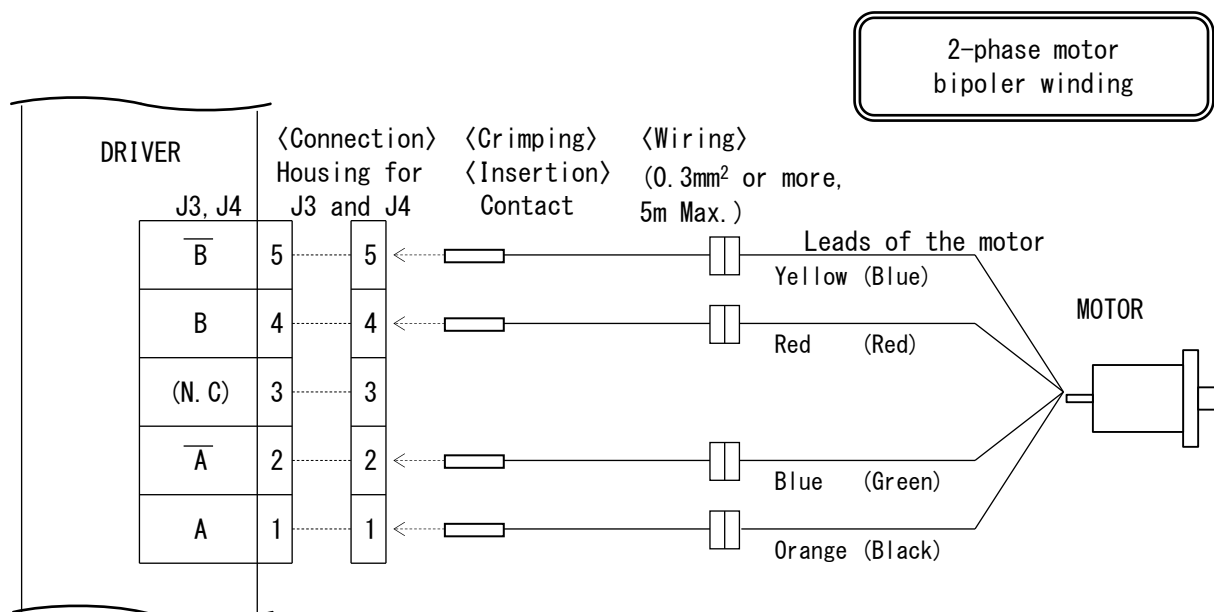

- The color indications for leads of the motor indicate motor of the SANYO DENKI CO., LTD.  
The color indications for leads of the motor in parentheses ( ) indicate motor of the ORIENTAL MOTOR Co., Ltd.
- Use a cable of 5m or less for the motor cable.
- Do not wiring anything to the pin number 3 of connector.
- Connect the motor with power off.

## 6 – 4. Inputting Power

**⚠ CAUTION**

Breakage of the machine or injury is apprehended due to unexpected behavior of the motor. Maintain the state where emergency stop is enabled at any time.

- (1) Input the DC power supply (DC+24V) in the cable that connected to No.1 and No.2 terminals of J2.

## ① Timing chart

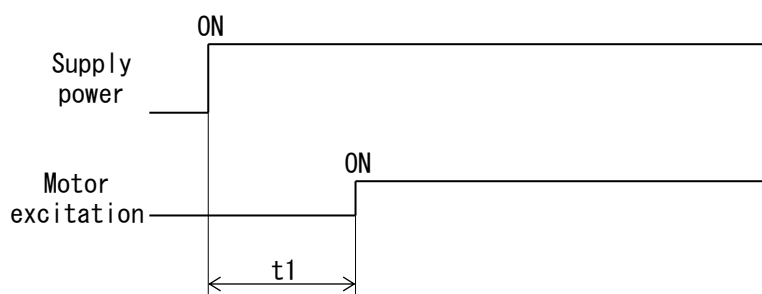

$t1 \leq 1s$  ( $t1$ : Time required for the motor to be enabled.)

- Connect the motor with power off.

## 7. Confirmation of Setting and Connection

### 7 – 1. Check Points

This product requires different switch setting and motor wiring depending on the motor used.

Check if the switch setting and the motor wiring are correctly performed.

Check Points		Check	Remarks
Setting of Axis1 DRIVE CURRENT SELECT switch	1/DRIVE I. SEL		
Setting of Axis1 HOLD CURRENT SELECT switch	1/HOLD I. SEL		
Setting of Axis1 MOTOR SELECT switch	1/MOTOR SEL		
Setting of Axis1 STEP ANGLE SELECT switch	1/STEP SEL		
Setting of Axis2 DRIVE CURRENT SELECT switch	2/DRIVE I. SEL		
Setting of Axis2 HOLD CURRENT SELECT switch	2/HOLD I. SEL		
Setting of Axis2 MOTOR SELECT switch	2/MOTOR SEL		
Setting of Axis2 STEP ANGLE SELECT switch	2/STEP SEL		
Setting of PULSE INPUT TYPE SELECT switch	SPI SEL		
Setting of EXTEND FUNCTION SELECT switch	OP SEL		
Connection of J1			
Connection of J2	DC+, DC-		
Connection of J3	1/MOTOR		
Connection of J4	2/MOTOR		

## 8. Maintenance and Check-up

### 8 – 1. Maintenance and Check-up

 **WARNING**

Injury or fire is apprehended due to unexpected behavior.  
Do not replace fuse.  
Do not disassemble, repair or modify.

- (1) As for maintenance inspections the engineer of the specialty shall do it.
- (2) We recommend that the following check-ups should be performed periodically:
  - Checking for any loosened contact on the connectors.
  - Checking for any flaw and crack on the cabling.
- (3) In case of failure, return the driver to us and have it repaired.

### 8 – 2. Troubleshooting

Trouble	Check Item	Assumed Cause
1. POWER LED does not come on.	<ul style="list-style-type: none"> <li>▪ Connection of power supply.</li> <li>▪ Value of power voltage.</li> </ul>	<ul style="list-style-type: none"> <li>▪ Wiring error with power supply.</li> <li>▪ Power voltage failure.</li> <li>▪ Driver failure.</li> </ul>
2. The motor is not excited. (It can be easily rotated by hand.)	<ul style="list-style-type: none"> <li>▪ Setting of the MOTOR SELECT switch.</li> <li>▪ Connection of the motor to the driver.</li> <li>▪ ON/OFF status of the M.F signal.</li> </ul>	<ul style="list-style-type: none"> <li>▪ Wrong setting for the motor selection.</li> <li>▪ Wiring error or disconnection with the motor and the driver.</li> <li>▪ The motor connected to the driver with power on.</li> <li>▪ The M.F signal is input.</li> <li>▪ Driver failure.</li> </ul>

Trouble	Check Item	Assumed Cause
3. The motor does not rotate. The motor behaves abnormally. The motor steps out.	<ul style="list-style-type: none"> <li>▪ The same check items as those under item 2 above.</li> <li>▪ Setting of the PULSE INPUT TYPE SELECT switch.</li> <li>▪ Connection of the pulse signal.</li> <li>▪ Voltage and wave form of the pulse signal.</li> <li>▪ Setting of the DRIVE CURRENT SELECT switch.</li> <li>▪ Setting of the STEP ANGLE SELECT switch.</li> </ul>	<ul style="list-style-type: none"> <li>▪ Wrong setting for the pulse input type.</li> <li>▪ Wiring error with the pulse signal line.</li> <li>▪ Pulse signal of wrong specifications.</li> <li>▪ DRIVE CURRENT is too low.</li> <li>▪ Wrong setting for the step angle.</li> <li>▪ Driver failure.</li> <li>▪ Motor failure.</li> </ul>
4. The motor steps out during acceleration.	<ul style="list-style-type: none"> <li>▪ Starting pulse speed.</li> <li>▪ Acceleration time.</li> </ul>	<ul style="list-style-type: none"> <li>▪ Starting pulse signal speed is too high.</li> <li>▪ Acceleration time is too short.</li> </ul>
5. The motor generates excessive heat.	<ul style="list-style-type: none"> <li>▪ Setting of the DRIVE CURRENT SELECT switch.</li> <li>▪ Setting of the HOLD CURRENT SELECT switch.</li> </ul>	<ul style="list-style-type: none"> <li>▪ DRIVE CURRENT is higher than the setting for the applicable motor.</li> <li>▪ The setting for HOLD CURRENT is too high.</li> </ul>
6. The alarm(ALM) LED flashes once.	<ul style="list-style-type: none"> <li>▪ The same check items as those under item 2 above in Axis1.</li> </ul>	<ul style="list-style-type: none"> <li>▪ Driver failure.</li> </ul>
7. The alarm(ALM) LED flashes twice.	<ul style="list-style-type: none"> <li>▪ The same check items as those under item 2 above in Axis2.</li> </ul>	<ul style="list-style-type: none"> <li>▪ Driver failure.</li> </ul>

(1) Short-circuiting of the motor output connector may cause the driver to fail.

- The motor output connector and the power line.
- The motor output connector and the motor output connector.

(2) When a large inertial load (motor rotor inertia x 5 or more) is operated at high speed (rotational speed  $20\text{s}^{-1}$  or more), regenerative energy will generate and increase the power supply voltage, which can damage the driver. Review the operating condition and make sure regenerative voltage will not generate.

When the failure phenomenon cannot be remedied, contact our office.

## 9. Storing and Disposal

### 9 – 1. Storing

(1) Keep the product in the following environment:

- Indoors (where it is not exposed to direct sun).
- Where ambient temperature and humidity are controlled within the range set out in the specifications.
- Where there is no explosive, corrosive or inflammable gas.
- Where it can be protected from dust, salt or iron powder.
- Where the product main frame is not exposed to direct vibration or shock.
- Where it is not exposed to splashes of water, oil or chemicals.

(2) Do not allow standing or placing anything heavy on the product.

### 9 – 2. Disposal

(1) Dispose of the product as industrial waste.

## 1 0. Specifications

### 1 0 – 1. General Specifications

Supply Power	DC+24V *1 (Ripple voltage P-P 2.0V or less) ●Rated input current : [DRIVE I. SEL ⇒ No. E set up] at DRIVE DC+24V: 5.4A (2.7A/Axis) *2 ●Rated input current : [HOLD I. SEL ⇒ Approx. 40% set up] at HOLD DC+24V: 1.0A (0.5A/Axis)	
Driving method	Bipolar constant current type	
Motor output current	●DRIVE CURRENT 0.20A/phase~2.40A/phase ●HOLD CURRENT Approx. 40% of DRIVE CURRENT (factory-set)	
Input Signal	●Drive pulse input (1/CW, 1/CCW, 2/CW, 2/CCW) ..... Photo-coupler input ●Extend function signal input (IN1, IN2) ..... Photo-coupler input	
Functions of Operating Sections	●MOTOR selection (MOTOR SEL) ●STEP ANGLE selection (STEP SEL) ●HOLD CURRENT selection (HOLD I. SEL) ●DRIVE CURRENT selection (DRIVE I. SEL) ●PULSE INPUT TYPE selection (SPI SEL) ●EXTEND FUNCTION selection (OP SEL)	
Alarm	●Overheat alarm, Abnormality detection (ALM LED)	
Operating Ambient Temperature	0°C ~ +50°C (No freezing allowed.)	
Operating Ambient Humidity	80%RH or less (No condensation allowed.)	
Storing Temperature	-10°C ~ +55°C (No freezing allowed.)	
Storing Humidity	80%RH or less (No condensation allowed.)	
Altitude	Up to 1000m above sea level	
Atmosphere	Indoor (Exposure to direct sun is not allowed.) Without any explosive, corrosive or inflammable gas, oil mist, or dust.	
Withstanding Vibration	No abnormality should be found after a vibration test at 10~55Hz, 0.15mm P-P	
Insulation resistance (nomal temperature and humidity)	DC connector - signal connector - Frame (Each other)	DC500V 100MΩ or more
Exterior Dimensions	<sup>H</sup> 64 × <sup>W</sup> 94 × <sup>D</sup> 28 (mm)	
Weight	100g	

\*1 Input voltage range is DC+24V±10%.

\*2 Use a power supply that provides sufficient input current.



## 10-2. I/O Signal

### (1) Example Circuit Connection

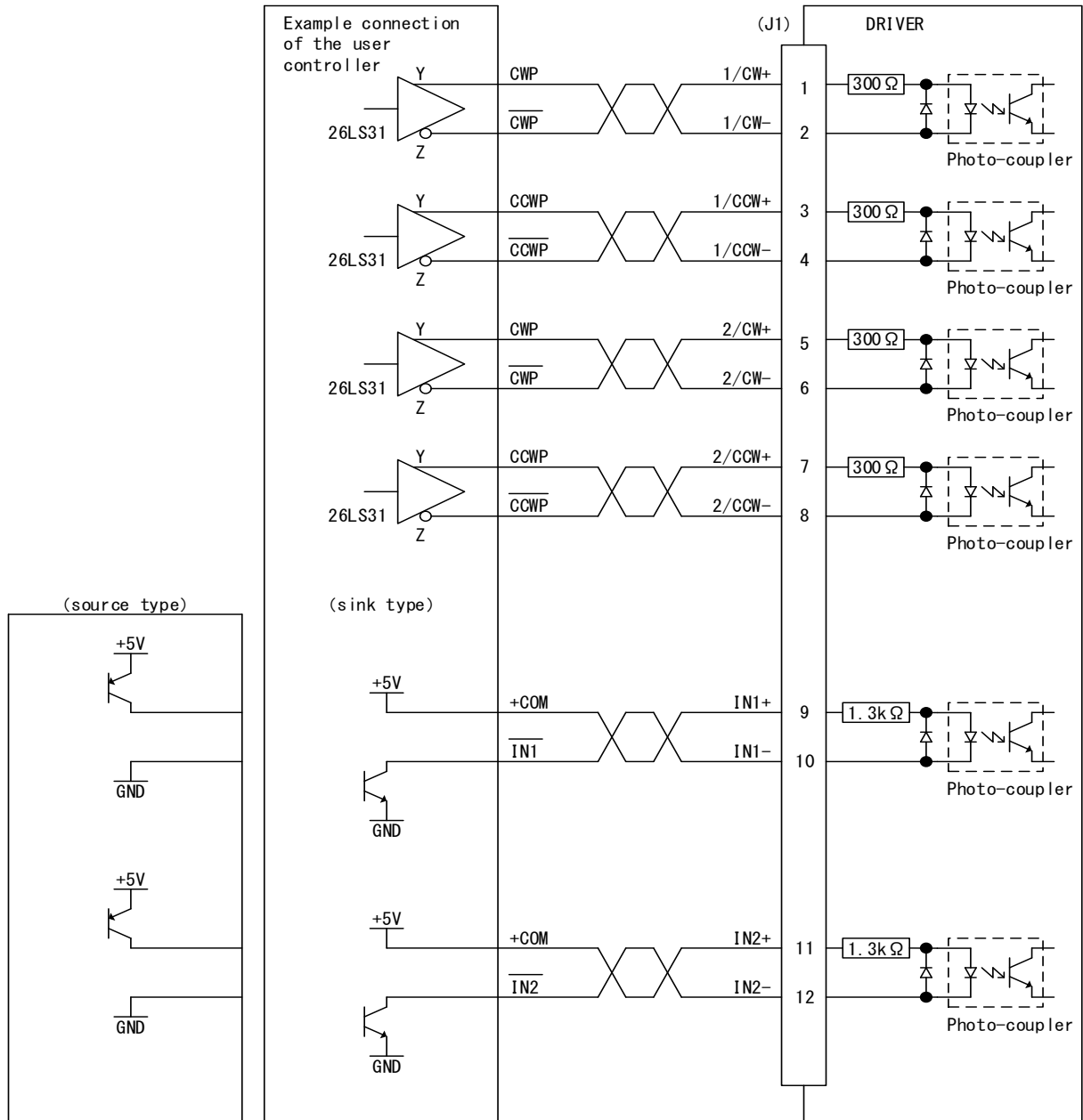

(2) Drive pulse input (1/CW, 1/CCW, 2/CW, 2/CCW)

① Operating current range : 5mA~14mA

The photo-coupler turns on with inter-terminal voltage of 3.1V~5.5V. (Photo-coupler diode  $V_F \doteq 1.5V$ )

② Timing chart

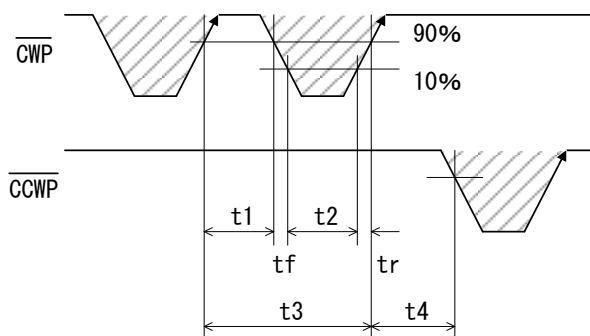

$t1 \geq 0.5 \mu s,$     $t2 \geq 0.5 \mu s,$     $t_f, t_r \leq 1 \mu s$   
 $t3 \geq 1 \mu s,$     $t4 > 1 \mu s$

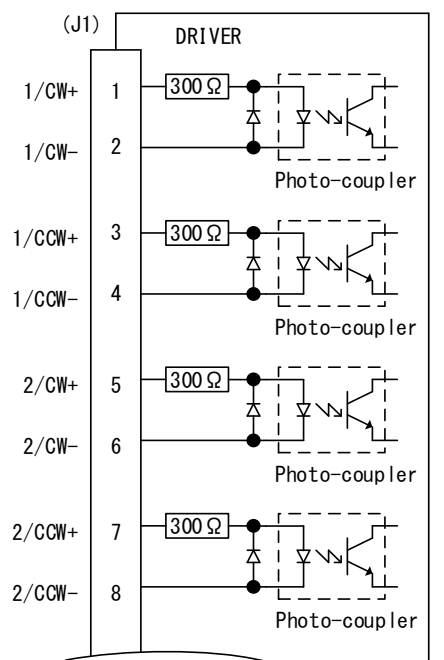

[To the line driver 26LS31]

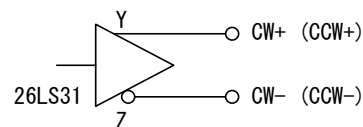

Maximum response frequency : 1MHz  
 (at 50% duty)

- The shaded area ( // ) indicates light emission from the photo-coupler, and the motor is driven at the rising edge (↑).  
 "t4" greatly varies according to the inertial moment including that of the motor.

③ Automatic switching for DRIVE/HOLD

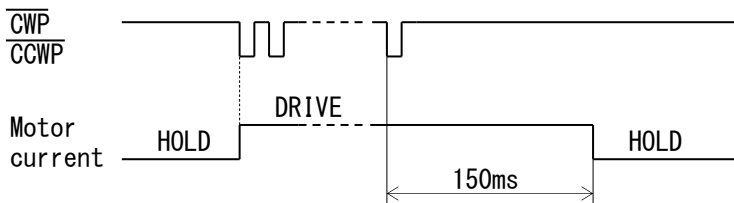

- Inputting drive pulse causes the current output to the motor to change from HOLD CURRENT to DRIVE CURRENT, which returns to HOLD CURRENT in about 150ms. DRIVE CURRENT continues if pulse is input on driving-state.

④ Direction of rotation

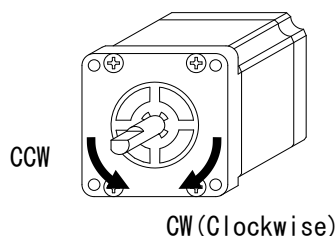

(3) Extend function signal input (IN1, IN2)

- ① Operating current range : 2.6mA~19.5mA  
 The photo-coupler turns on with inter-terminal voltage of 4.5V~26.4V.  
 (Photo-coupler diode  $V_F \doteq 1.1V$ )

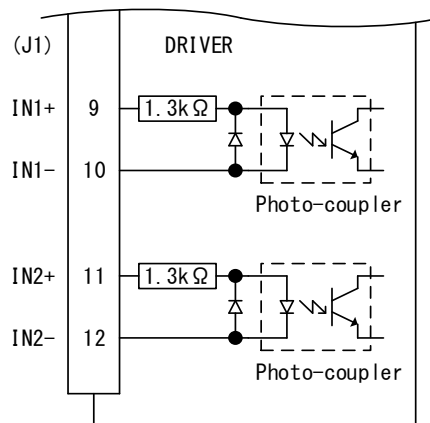

**⚠ CAUTION**

Deterioration of the holding power with the motor may cause breakage of the machine or injury.  
 Check safety before inputting.

② Motor excitation stop input (M.F)

- In the case that OP SEL set as below,  
 The extend function signal input can use as the motor excitation stop input.

Set this switch with power OFF.

OP SEL switch			Function
4	3	2	
OFF	OFF	OFF	Motor excitation stop input (M.F) (Factory setting)

- The Axix1 motor output current is shut off with the photo-coupler of IN1 ON.  
 The Axix1 motor output current is shut off with the photo-coupler of IN2 ON.  
 At this time, the motor torque changes to detent torque.
- When this signal is input, motor torque may be lost, resulting in failure to retain the load transported.  
 In particular, this risk is high with the vertical drive (such as the Z-axis).

③ Timing chart

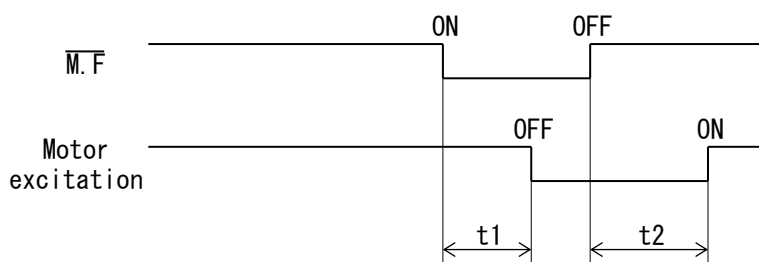

$t1 \leq 5ms$  ( $t1$ : Time required for the motor output current to be shut off.)  
 $t2 \leq 100ms$  ( $t2$ : Time required for the motor to be enabled.)

## 1 0 – 3. Alarm (ALM) LED

### WARNING

Overheating may cause fire.  
Stop operation when this LED comes on.

### CAUTION

Breakage of the machine or injury is apprehended due to unexpected behavior of the motor.  
Stop operation when this LED flashes.

#### (1) Overheat alarm

- In case of internal temperature of the driver reaches approx. 70°C or more, ALM LED comes on. At this time the motor output current is not blocked.
- When this LED comes on, stop operation and check if there is any abnormality occurring with the motor and the driver.
- Provide mechanical cooling, for example, if this LED comes on while no abnormality is detected.
- Continuous operation is possible unless this LED comes on.

#### (2) Abnormality detection

- When abnormality is detected on Axis1, the ALM LED flashes once.
- When abnormality is detected on Axis2, the ALM LED flashes twice.
- When this LED flashes, stop operation and check if there is any abnormality occurring with the motor and the driver.
- Please refer to “8-2. Troubleshooting” for the cause.

1 0 - 4. Dimensions

(Unit : mm)

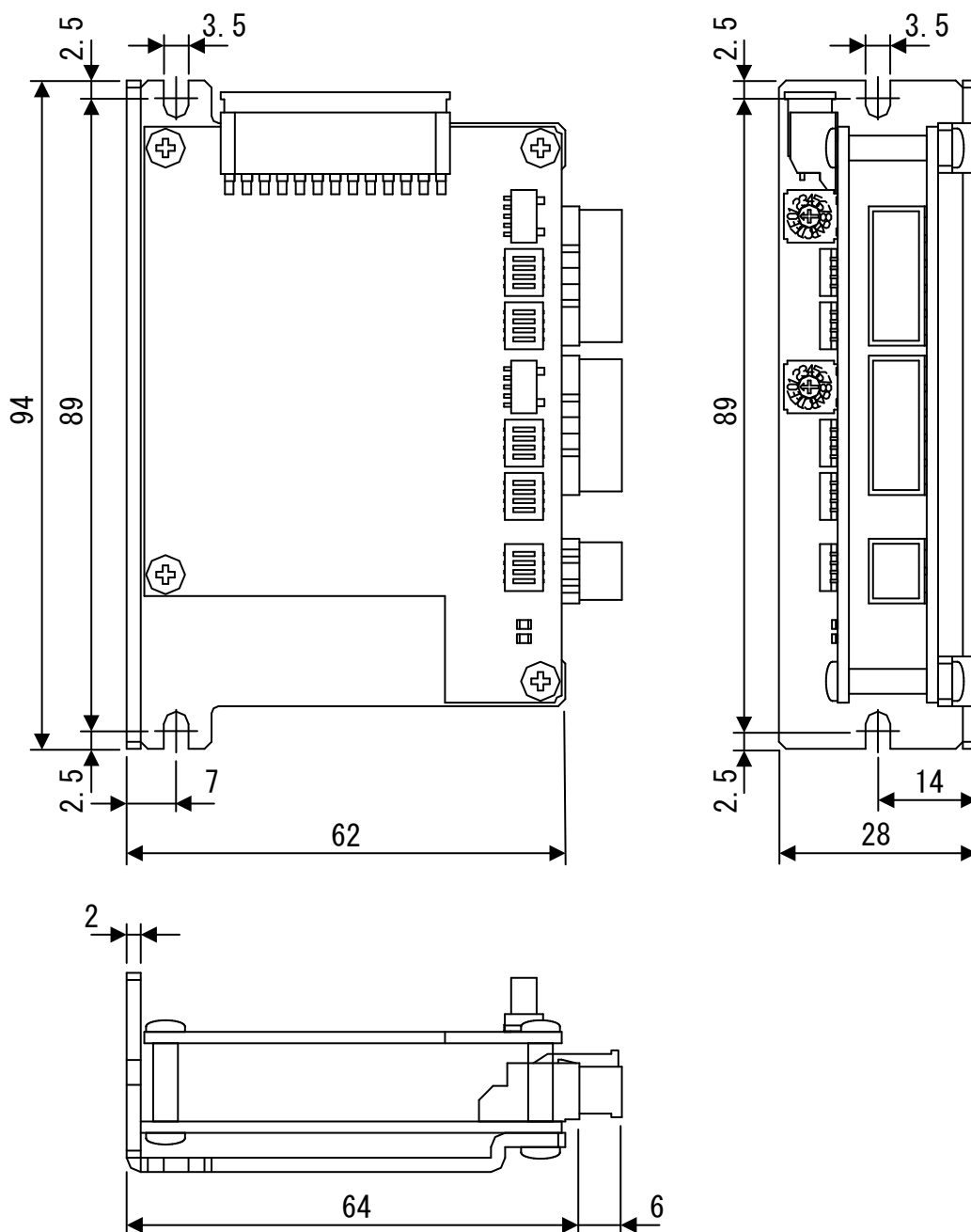

## 1 0 – 5. Applicable Motors

- (1) It can drive the 5-phase stepping motor of new pentagon connection ranging from 0.35A/phase to 2.40A/phase, and the 2-phase stepping motor of bipolar winding ranging from 0.35A/phase to 2.40A/phase.

### ① Examples of applicable motors

#### ●5-phase stepping motor of new pentagon connection

SANYO DENKI Co., LTD.		Basic Angle (°)	Current (A/phase)	Setting DRIVE I. SEL switch No.	Setting MOTOR SEL switch	Torque Data Fig. No.
□28mm	SH5281-7241 (7211)	0.72	0.75	4	ON	—
	SH5285-7241 (7211)	0.72	0.75	4	ON	—
□42mm	103F5505-7241	0.72	0.75	4	ON	Fig. 1
	103F5508-7241	0.72	0.75	4	ON	—
	103F5510-7241	0.72	0.75	4	ON	Fig. 2
□60mm	103F7852-8241	0.72	1.4	7	ON	Fig. 3
	103F7853-8241	0.72	1.4	7	ON	—

ORIENTAL MOTOR Co., Ltd.		Basic Angle (°)	Current (A/phase)	Setting DRIVE I. SEL switch No.	Setting MOTOR SEL switch	Torque Data Fig. No.
□28mm	PK523PA (B)	0.72	0.35	1	ON	Fig. 4
	PKP523N12A (B)	0.72	1.2	6	ON	—
□42mm	PK543-A (B)	0.72	0.75	4	ON	Fig. 5
	PKP543N18A2 (B2)	0.72	1.8	A	ON	—
□60mm	PK566-A (B)	0.72	0.75	4	ON	Fig. 6
	PK566H-A (B)	0.72	1.4	7	ON	Fig. 7
	PKP566FN24A2 (B2)	0.72	2.4	E	ON	—
Factory Setting				4	ON	—

( ) : Both Axis

- Please contact us if you want to use the motor other than the above to our office.

## ●2-phase stepping motor of bipolar winding

SANYO DENKI Co., LTD.		Basic Angle (°)	Current (A/phase)	Setting DRIVE I. SEL switch No.	Setting MOTOR SEL switch	Torque Data Fig. No.
□28mm	SH2281-5771 (5731)	1.8	1.0	5	OFF	—
	SH2285-5771 (5731)	1.8	1.0	5	OFF	—
□42mm	103H5205-5240 (5210)	1.8	1.0	5	OFF	Fig. 8
	103H5210-5240 (5210)	1.8	1.0	5	OFF	—
□56mm	103H7123-5740 (5710)	1.8	2.0	B	OFF	Fig. 9

ORIENTAL MOTOR Co., Ltd.		Basic Angle (°)	Current (A/phase)	Setting DRIVE I. SEL switch No.	Setting MOTOR SEL switch	Torque Data Fig. No.
□28mm	PKP223D15A2 (B2)	1.8	1.5	8	OFF	—
□42mm	PKP243D15A2 (B2)	1.8	1.5	8	OFF	Fig. 10
	PKP243D23A2 (B2)	1.8	2.3	D	OFF	—
□56.4mm	PKP266D14A2 (B2)	1.8	1.4	7	OFF	Fig. 11
Factory Setting				4	ON	—

( ) : Both Axis

●Please contact us if you want to use the motor other than the above to our office.

(2) It can drive 2.80A/phase motor, when the DRIVE CURRENT is set to 2.40A/phase.

① Examples of applicable motors

●5-phase stepping motor of new pentagon connection

SANYO DENKI Co., LTD.		Basic Angle (°)	Current (A/phase)	Setting DRIVE I. SEL switch No.	Setting MOTOR SEL switch	Torque Data Fig. No.
□60mm	SF5601-9251	0.72	2.8	E	ON	—
	SF5602-9251	0.72	2.8	E	ON	Fig. 12
	SF5603-9251	0.72	2.8	E	ON	—
Factory Setting				4	ON	—

●2-phase stepping motor of bipolar winding

ORIENTAL MOTOR Co., Ltd.		Basic Angle (°)	Current (A/phase)	Setting DRIVE I. SEL switch No.	Setting MOTOR SEL switch	Torque Data Fig. No.
□56.4mm	PKP266D28A2 (B2)	1.8	2.8	E	OFF	Fig. 13
Factory Setting				4	ON	—

( ) : Both Axis

●Please contact us if you want to use the motor other than the above to our office.



## 10-5. Torque Characteristics

- (1) Representations in the torque characteristics table are made in terms of the motor rotation ( $s^{-1}$ , r/min) vs. torque ( $N \cdot m$ ).

Motor rotation ( $s^{-1}$ ) and drive pulse frequency (Hz) are converted as follows:

$$\text{Motor rotation}(s^{-1}) \times \frac{360^{\circ}}{\text{Step angle}} = \text{Drive pulse input frequency(Hz)}$$

Motor rotation ( $s^{-1}$ ) and motor rotation (r/min) are converted as follows:

$$\text{Motor rotation}(s^{-1}) \times 60 = \text{Motor rotation(r/min)}$$

● Use the motor rotation at  $100s^{-1}$  (6000r/min) or less.

- (2) The Maximum Starting Pulse Rate is represented as "fs" by the value at zero inertial load.
- (3) Upon operation, provide adequate allowance for torque.
- (4) The stepping motor may attain high temperature, depending on the operational conditions.  
Use the stepping motor according to the Instructions Manual produced by motormakers.

**Instructions Manual**

**Fig. 1**

QDB-M240X2  
103F5505-7241  
0.75A/PHASE

MOTOR SEL = ON  
DRIVE I. SEL = No. 4  
DC24V

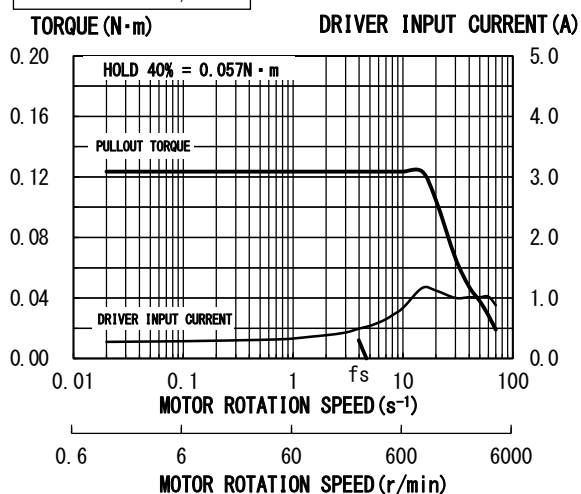

**Fig. 2**

QDB-M240X2  
103F5510-7241  
0.75A/PHASE

MOTOR SEL = ON  
DRIVE I. SEL = No. 4  
DC24V

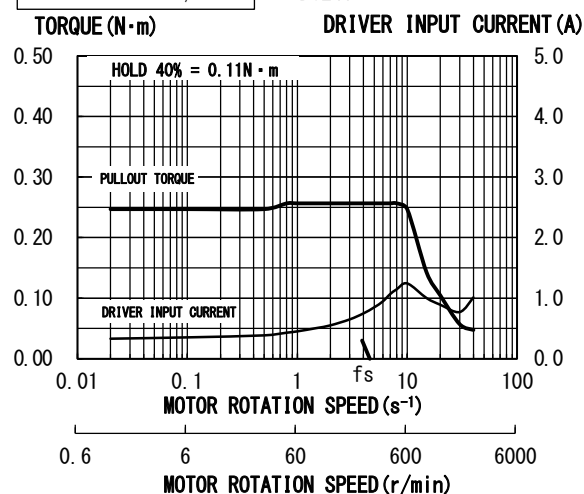

**Fig. 3**

QDB-M240X2  
103F7852-8241  
1.4A/PHASE

MOTOR SEL = ON  
DRIVE I. SEL = No. 7  
DC24V

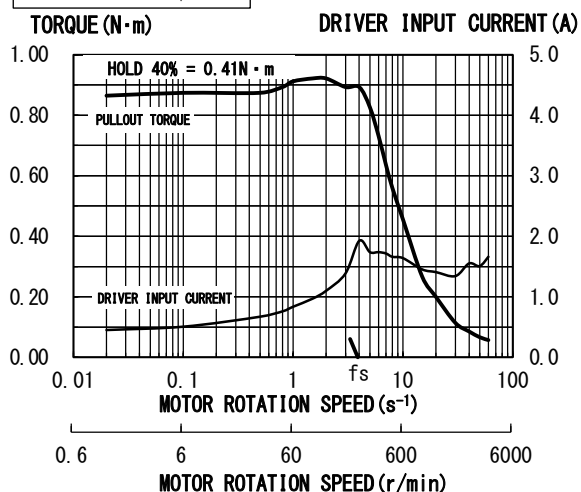

**Instructions Manual**

**Fig. 4**

QDB-M240X2  
PK523PA (B)  
0.35A/PHASE

MOTOR SEL = ON  
DRIVE I. SEL = No. 1  
DC24V

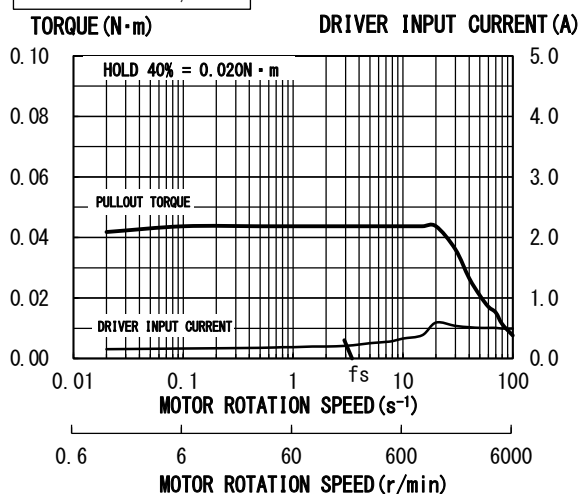

**Fig. 5**

QDB-M240X2  
PK543-A (B)  
0.75A/PHASE

MOTOR SEL = ON  
DRIVE I. SEL = No. 4  
DC24V

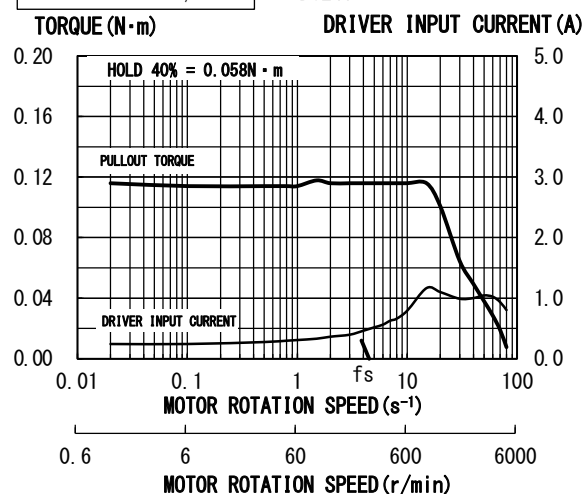

**Fig. 6**

QDB-M240X2  
PK566-A (B)  
0.75A/PHASE

MOTOR SEL = ON  
DRIVE I. SEL = No. 4  
DC24V

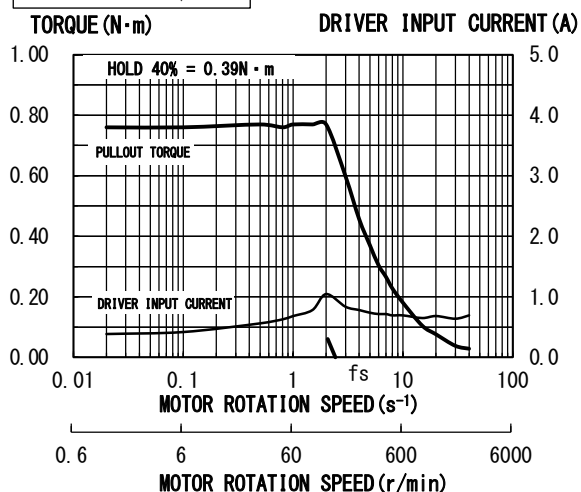

**Fig. 7**

QDB-M240X2  
PK566H-A (B)  
1.4A/PHASE

MOTOR SEL = ON  
DRIVE I. SEL = No. 7  
DC24V

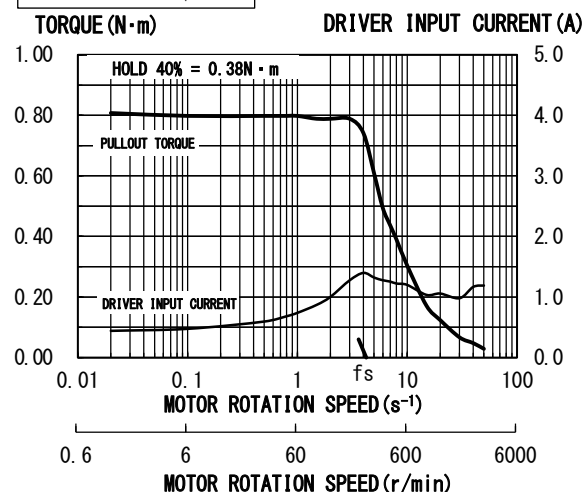

**Instructions Manual**

**Fig. 8**

QDB-M240X2  
103H5205-5240 (5210)  
1.0A/PHASE

MOTOR SEL = OFF  
DRIVE I. SEL = No. 5  
DC24V

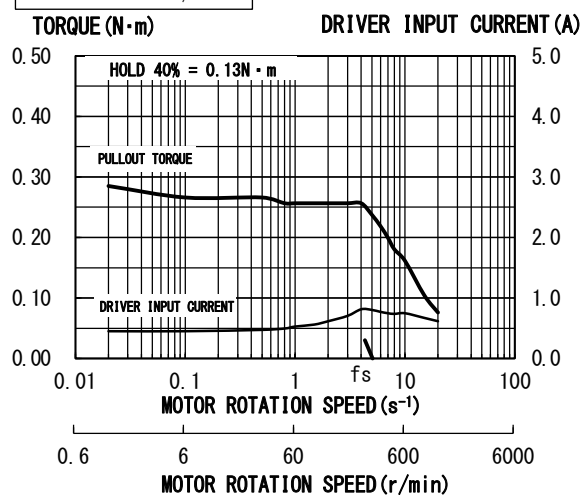

**Fig. 9**

QDB-M240X2  
103H7123-5740 (5710)  
2.0A/PHASE

MOTOR SEL = OFF  
DRIVE I. SEL = No. B  
DC24V

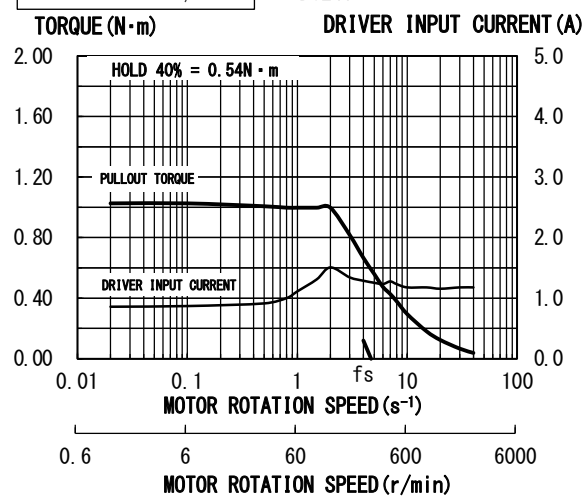

**Instructions Manual**

**Fig. 10**

QDB-M240X2  
PKP243D15A2 (B2)  
1.5A/PHASE

MOTOR SEL = OFF  
DRIVE I. SEL = No. 8  
DC24V

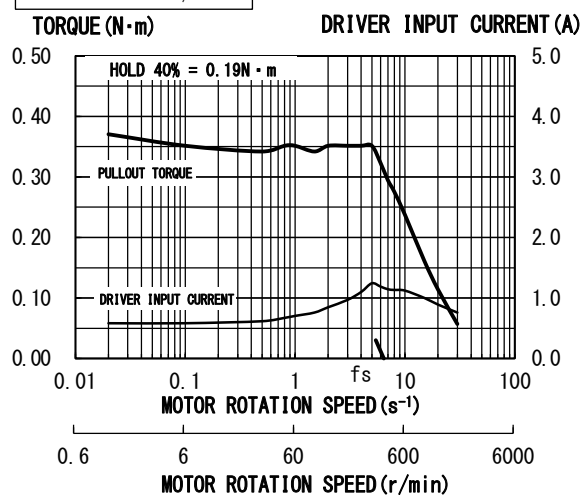

**Fig. 11**

QDB-M240X2  
PKP266D14A2 (B2)  
1.4A/PHASE

MOTOR SEL = OFF  
DRIVE I. SEL = No. 7  
DC24V

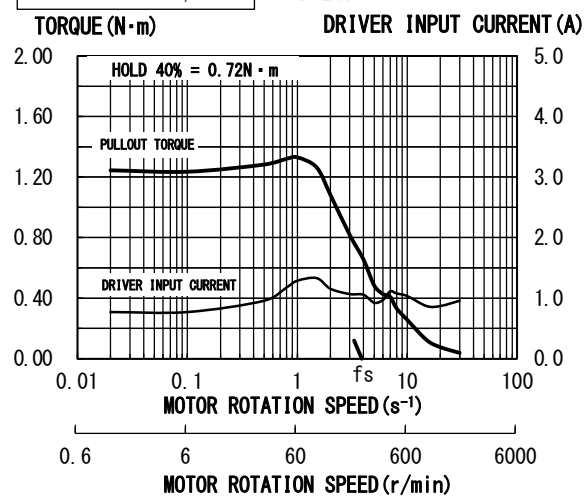
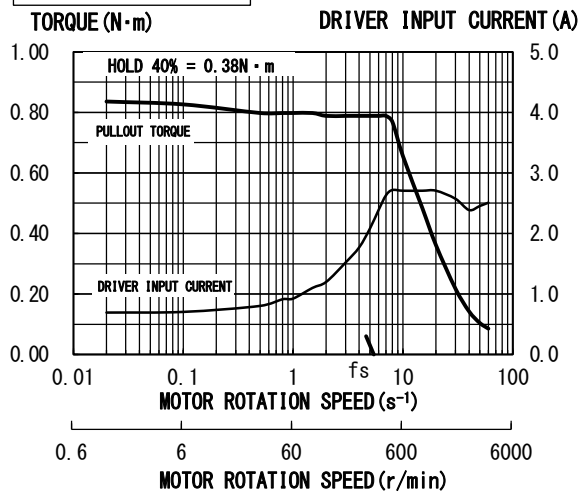

Fig. 12

QDB-M240X2  
 SF5602-9251  
 2.8A/PHASE

MOTOR SEL = ON  
 DRIVE I. SEL = No. E  
 DC24V



**Fig. 13**

QDB-M240X2  
 PKP266D28A2 (B2)  
 2.8A/PHASE

MOTOR SEL = OFF  
 DRIVE I. SEL = No. E  
 DC24V

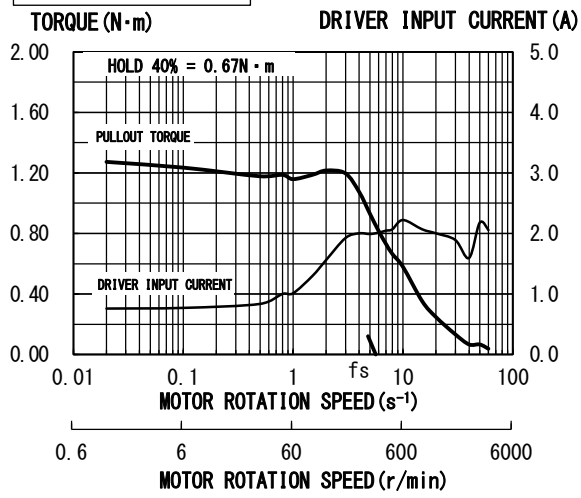

## 10-7. Conforming to Europe standards

### (1) Low voltage directive

This product is not subject to the EC's Low Voltage Directive by the following.

- This product should be installed within an enclosure.
- For the driver's power supply, use a DC power supply with reinforced insulation on its primary and secondary sides.

### (2) EMC directive

This product declares the CE marking based on the EMC Directive by oneself.

#### ● Applicable Standards

EN61000-6-4

EN61000-6-2

#### ● This product conducted EMC measurement with the system configuration for EMC.

- EMC characteristic may vary depending on the configuration of the equipment that contains the driver or stepping motor. Be sure to conduct EMC measurement with the product assembled in your equipment.

#### Configuration

The metallic enclosure and shielded wires and ferrite core work to shield noise.

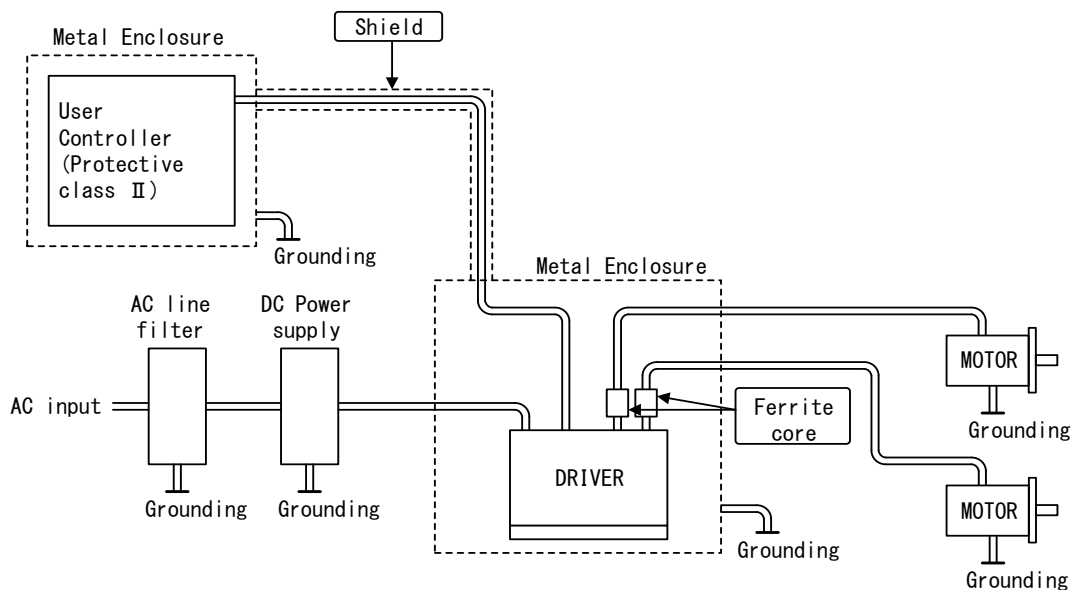



The main parts which revised by this manual

Parts	Content

---

## **Technical Service**

TEL. (042) 664-5382 FAX. (042) 666-5664  
E-mail [s-support@melec-inc.com](mailto:s-support@melec-inc.com)

---

## **Sales and Service**

TEL. (042) 664-5384 FAX. (042) 666-2031  
URL:<http://www.melec-inc.com>

Melec Inc. Control equipment marketing department  
516-10, Higashiasakawa-cho, Hachioji-shi, Tokyo 193-0834, Japan

---

This Operating Manual is subject to change without prior notice  
for the purpose of product improvement.

C1807