

Melec



5-PHASE STEPPING MOTOR Instructions Manual (For designers' use)

USER'S MANUAL

Please ensure to read and understand this Instructions Manual before using the product. Please keep this Instructions Manual at hand so that it is always available for reference.

Introduction

This Instructions Manual describes the safe and proper method of handling "5-phase Stepping Motor" with emphasis on the specifications, assuming that our readers are engaged in designing of control devices incorporating stepping motors.

Please ensure to read and understand this Instructions Manual before using the product.

Please keep this Instructions Manual at hand so that it is always available for reference.

Descriptions in this manual on safety matters:

This product must be operated and used properly.

Otherwise, or when it is operated and used erroneously, unforeseen accidents may occur, causing physical injuries or property damages.

Majority of these accidents can be avoided if you are well informed of hazardous circumstances in advance.

Consequently, this instructions manual describes all the hazardous and dangerous circumstances and situations which can be foreseen and anticipated as well as necessary precautions.

All the above descriptions are being titled by the following symbol-marks and signal-words, namely:



Represents warnings ignorance of which can cause accidents involving fatal or serious physical injuries.

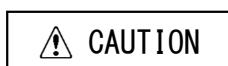

Represents cautions ignorance of which can cause accidents involving minor physical injuries or property damages.

Introduction

Descriptions in this manual on safety matters:

	CONTENTS	PAGE
1.	Safety	
1-1.	Safety Precautions	4
2.	Overview	
2-1.	Kind of motors	5
2-2.	Motor and driver combination	5
3.	Specifications	
3-1.	Specifications list	
(1)	SANYO DENKI CO.,LTD.	6
(2)	TAMAGAWA SEIKI CO.,LTD.	6
3-2.	General specifications	
(1)	SANYO DENKI CO.,LTD.	7
(2)	TAMAGAWA SEIKI CO.,LTD.	7
(3)	Encoder specifications	7A
3-3.	Wiring diagram /Direction of rotation	7B
3-4.	Dimensions	8

The main parts which revised by this manual

1. Safety

1 – 1. Safety Precautions

 **WARNING**

- (1) This product is not designed or manufactured for application for equipment requiring high level of reliability such as equipment related to nuclear energy, aeronautics-related equipment, automobiles, ships, medical appliances directly handling the human body and equipment that might seriously affect properties.
- (2) Do not use or keep the product in explosive or corrosive environments, in the presence of flammable gases, locations subjected to splashing water, fine particles, soot, steam, or exposed to radiation or direct sunshine. Doing so may cause injury or fire.
- (3) Do not transport, move, install the product, perform connections or inspections when the power is on. Doing so may cause electric shock, injury or fire.
- (4) Only qualified personnel are allowed to transport, move, install the product, perform connections or inspections. Failure to do so may cause injury or fire.
- (5) Connect the cables securely according to the wiring diagram in order to prevent fire. Moreover, do not forcibly bend, pull or pinch the cable. Failure to do so may cause injury or fire.

 **CAUTION**

- (6) Do not touch the motor during operation or immediately after stopping. Doing so may cause burn on the skin due to overheating of the motor.
- (7) Ensure to use this product according to the method specified in the Instructions Manual and within the specifications.
- (8) Depending on the operational conditions, the stepping motor may step out when it is on holding-state or driving-state. In particular, the load in transport may fall if the motor steps out on the vertical drive (such as the Z-axis). Start operation after test run for deliberate confirmation of operation.
- (9) Provide fail-safe measures so that the entire system may operate in a safe mode even in cases of the external power supply failure, disconnection of the signal line, or any failure on the motor.

2. Overview

R2

2-1. Kind of motors

In our company, 5-phase stepping motor is prepared.
 It is possible to use it by combining with driver of our company for 5-phase stepping motor.



2-2. Motor and driver combination

The combination with the following driver is a typical example.
 Refer to each driver's instruction manual for the torque characteristic.

Outside Dimensions (mm)	Model name		Maximum Holding Torque (N·m)	Current (A/phase)	Maker	Combination example with driver of MELEC Inc.												
	Both axes	Single axis				ODB-M240X2	ODB-M241X2	ODB-MS240X2	ODB-MS280	ODB-MS450	GDB-5K40	GDB-5K50	GD-5410v1	GD-5510-01	GD-5610v1	ADB-5F41EL		
<input type="checkbox"/> 20	TS3682N11	TS3682N1	0.013	0.35	TAMAGAWA SEIKI CO., LTD.	<input type="checkbox"/>	<input type="checkbox"/>	<input type="checkbox"/>	<input type="checkbox"/>	<input type="checkbox"/>	<input type="checkbox"/>	<input type="checkbox"/>	<input type="checkbox"/>	<input type="checkbox"/>	<input type="checkbox"/>	<input type="checkbox"/>	<input type="checkbox"/>	
	TS3682N12	TS3682N2	0.024	0.35		<input type="checkbox"/>	<input type="checkbox"/>	<input type="checkbox"/>	<input type="checkbox"/>	<input type="checkbox"/>	<input type="checkbox"/>	<input type="checkbox"/>	<input type="checkbox"/>	<input type="checkbox"/>	<input type="checkbox"/>	<input type="checkbox"/>	<input type="checkbox"/>	
<input type="checkbox"/> 24	TS3664N11E2	TS3664N1E2	0.018	0.75		<input type="checkbox"/>	<input type="checkbox"/>	<input type="checkbox"/>	<input type="checkbox"/>	<input type="checkbox"/>	<input type="checkbox"/>	<input type="checkbox"/>	<input type="checkbox"/>	<input type="checkbox"/>	<input type="checkbox"/>	<input type="checkbox"/>	<input type="checkbox"/>	
	TS3664N12E4	TS3664N2E4	0.028	0.75		<input type="checkbox"/>	<input type="checkbox"/>	<input type="checkbox"/>	<input type="checkbox"/>	<input type="checkbox"/>	<input type="checkbox"/>	<input type="checkbox"/>	<input type="checkbox"/>	<input type="checkbox"/>	<input type="checkbox"/>	<input type="checkbox"/>	<input type="checkbox"/>	
<input type="checkbox"/> 28	SH5281-3211	SH5281-3241	0.045	0.35		<input type="checkbox"/>	<input type="checkbox"/>	<input type="checkbox"/>	<input type="checkbox"/>	<input type="checkbox"/>	<input type="checkbox"/>	<input type="checkbox"/>	<input type="checkbox"/>	<input type="checkbox"/>	<input type="checkbox"/>	<input type="checkbox"/>	<input type="checkbox"/>	
	SH5285-3211	SH5285-3241	0.085	0.35		<input type="checkbox"/>	<input type="checkbox"/>	<input type="checkbox"/>	<input type="checkbox"/>	<input type="checkbox"/>	<input type="checkbox"/>	<input type="checkbox"/>	<input type="checkbox"/>	<input type="checkbox"/>	<input type="checkbox"/>	<input type="checkbox"/>	<input type="checkbox"/>	
	SH5281-7211	SH5281-7241	0.041	0.75		<input type="checkbox"/>	<input type="checkbox"/>	<input type="checkbox"/>	<input type="checkbox"/>	<input type="checkbox"/>	<input type="checkbox"/>	<input type="checkbox"/>	<input type="checkbox"/>	<input type="checkbox"/>	<input type="checkbox"/>	<input type="checkbox"/>	<input type="checkbox"/>	
	SH5285-7211	SH5285-7241	0.078	0.75		<input type="checkbox"/>	<input type="checkbox"/>	<input type="checkbox"/>	<input type="checkbox"/>	<input type="checkbox"/>	<input type="checkbox"/>	<input type="checkbox"/>	<input type="checkbox"/>	<input type="checkbox"/>	<input type="checkbox"/>	<input type="checkbox"/>	<input type="checkbox"/>	
	SH5281-7411	-	0.032	0.75		<input type="checkbox"/>	<input type="checkbox"/>	<input type="checkbox"/>	<input type="checkbox"/>	<input type="checkbox"/>	<input type="checkbox"/>	<input type="checkbox"/>	<input type="checkbox"/>	<input type="checkbox"/>	<input type="checkbox"/>	<input type="checkbox"/>	<input type="checkbox"/>	
	SH5285-7411	-	0.06	0.75		<input type="checkbox"/>	<input type="checkbox"/>	<input type="checkbox"/>	<input type="checkbox"/>	<input type="checkbox"/>	<input type="checkbox"/>	<input type="checkbox"/>	<input type="checkbox"/>	<input type="checkbox"/>	<input type="checkbox"/>	<input type="checkbox"/>	<input type="checkbox"/>	
	<input type="checkbox"/> 42	103F5505-7211	103F5505-7241	0.13		0.75	SANYODENKI CO., LTD.	<input type="checkbox"/>	<input type="checkbox"/>	<input type="checkbox"/>	<input type="checkbox"/>	<input type="checkbox"/>	<input type="checkbox"/>	<input type="checkbox"/>	<input type="checkbox"/>	<input type="checkbox"/>	<input type="checkbox"/>	<input type="checkbox"/>
103F5505-8211		103F5505-8241	0.13	1.4		<input type="checkbox"/>		<input type="checkbox"/>	<input type="checkbox"/>	<input type="checkbox"/>	<input type="checkbox"/>	<input type="checkbox"/>	<input type="checkbox"/>	<input type="checkbox"/>	<input type="checkbox"/>	<input type="checkbox"/>	<input type="checkbox"/>	<input type="checkbox"/>
103F5508-7211		103F5508-7241	0.18	0.75	<input type="checkbox"/>	<input type="checkbox"/>		<input type="checkbox"/>	<input type="checkbox"/>	<input type="checkbox"/>	<input type="checkbox"/>	<input type="checkbox"/>	<input type="checkbox"/>	<input type="checkbox"/>	<input type="checkbox"/>	<input type="checkbox"/>	<input type="checkbox"/>	
103F5508-8211		103F5508-8241	0.18	1.4	<input type="checkbox"/>	<input type="checkbox"/>		<input type="checkbox"/>	<input type="checkbox"/>	<input type="checkbox"/>	<input type="checkbox"/>	<input type="checkbox"/>	<input type="checkbox"/>	<input type="checkbox"/>	<input type="checkbox"/>	<input type="checkbox"/>	<input type="checkbox"/>	
103F5510-7211		103F5510-7241	0.245	0.75	<input type="checkbox"/>	<input type="checkbox"/>		<input type="checkbox"/>	<input type="checkbox"/>	<input type="checkbox"/>	<input type="checkbox"/>	<input type="checkbox"/>	<input type="checkbox"/>	<input type="checkbox"/>	<input type="checkbox"/>	<input type="checkbox"/>	<input type="checkbox"/>	
103F5510-8211		103F5510-8241	0.25	1.4	<input type="checkbox"/>	<input type="checkbox"/>		<input type="checkbox"/>	<input type="checkbox"/>	<input type="checkbox"/>	<input type="checkbox"/>	<input type="checkbox"/>	<input type="checkbox"/>	<input type="checkbox"/>	<input type="checkbox"/>	<input type="checkbox"/>	<input type="checkbox"/>	
with Encoder		103F5510-72XE43	0.245	0.75	<input type="checkbox"/>	<input type="checkbox"/>		<input type="checkbox"/>	<input type="checkbox"/>	<input type="checkbox"/>	<input type="checkbox"/>	<input type="checkbox"/>	<input type="checkbox"/>	<input type="checkbox"/>	<input type="checkbox"/>	<input type="checkbox"/>	<input type="checkbox"/>	
<input type="checkbox"/> 60	103F7851-8211	103F7851-8241	0.55	1.4	<input type="checkbox"/>	<input type="checkbox"/>		<input type="checkbox"/>	<input type="checkbox"/>	<input type="checkbox"/>	<input type="checkbox"/>	<input type="checkbox"/>	<input type="checkbox"/>	<input type="checkbox"/>	<input type="checkbox"/>	<input type="checkbox"/>	<input type="checkbox"/>	
	103F7852-8211	103F7852-8241	0.87	1.4	<input type="checkbox"/>	<input type="checkbox"/>		<input type="checkbox"/>	<input type="checkbox"/>	<input type="checkbox"/>	<input type="checkbox"/>	<input type="checkbox"/>	<input type="checkbox"/>	<input type="checkbox"/>	<input type="checkbox"/>	<input type="checkbox"/>	<input type="checkbox"/>	
	103F7853-8211	103F7853-8241	1.67	1.4	<input type="checkbox"/>	<input type="checkbox"/>		<input type="checkbox"/>	<input type="checkbox"/>	<input type="checkbox"/>	<input type="checkbox"/>	<input type="checkbox"/>	<input type="checkbox"/>	<input type="checkbox"/>	<input type="checkbox"/>	<input type="checkbox"/>	<input type="checkbox"/>	
	-	SF5601-9251	0.5	2.8	<input type="checkbox"/>	<input type="checkbox"/>		<input type="checkbox"/>	<input type="checkbox"/>	<input type="checkbox"/>	<input type="checkbox"/>	<input type="checkbox"/>	<input type="checkbox"/>	<input type="checkbox"/>	<input type="checkbox"/>	<input type="checkbox"/>	<input type="checkbox"/>	
	-	SF5602-9251	0.83	2.8	<input type="checkbox"/>	<input type="checkbox"/>		<input type="checkbox"/>	<input type="checkbox"/>	<input type="checkbox"/>	<input type="checkbox"/>	<input type="checkbox"/>	<input type="checkbox"/>	<input type="checkbox"/>	<input type="checkbox"/>	<input type="checkbox"/>	<input type="checkbox"/>	
	-	SF5603-9251	1.55	2.8	<input type="checkbox"/>	<input type="checkbox"/>		<input type="checkbox"/>	<input type="checkbox"/>	<input type="checkbox"/>	<input type="checkbox"/>	<input type="checkbox"/>	<input type="checkbox"/>	<input type="checkbox"/>	<input type="checkbox"/>	<input type="checkbox"/>	<input type="checkbox"/>	
	with Encoder	103F7851-82XE42	0.55	1.4	<input type="checkbox"/>	<input type="checkbox"/>		<input type="checkbox"/>	<input type="checkbox"/>	<input type="checkbox"/>	<input type="checkbox"/>	<input type="checkbox"/>	<input type="checkbox"/>	<input type="checkbox"/>	<input type="checkbox"/>	<input type="checkbox"/>	<input type="checkbox"/>	
	103F7852-82XE42	0.87	1.4	<input type="checkbox"/>	<input type="checkbox"/>	<input type="checkbox"/>		<input type="checkbox"/>	<input type="checkbox"/>	<input type="checkbox"/>	<input type="checkbox"/>	<input type="checkbox"/>	<input type="checkbox"/>	<input type="checkbox"/>	<input type="checkbox"/>	<input type="checkbox"/>		

3. Specifications

R2

3-1. Specifications list

(1) SANYO DENKI CO., LTD.

Outside Dimensions (mm)	Model name		Maximum Holding Torque (N·m)	Rotor Inertia (Kg. m ²)	Current (A/phase)	D. C Resistance (Ω ±10%)	Step Angle (°)	Weight (kg)	Length (mm)	Allowable Radial Load (N) *1	Allowable Thrust Load (N)
	Both axes	Single axis									
□28	SH5281-3211	SH5281-3241	0.045	10x10 ⁻⁷	0.35	4.5	0.72	0.11	32	42	3
	SH5285-3211	SH5285-3241	0.085	22x10 ⁻⁷	0.35	5	0.72	0.2	51.5	49	3
	SH5281-7211	SH5281-7241	0.041	10x10 ⁻⁷	0.75	1.05	0.72	0.11	32	42	3
	SH5285-7211	SH5285-7241	0.078	22x10 ⁻⁷	0.75	1.15	0.72	0.2	51.5	49	3
	SH5281-7411		0.032	9x10 ⁻⁷	0.75	0.8	0.72	0.11	32	40	3
	SH5285-7411		0.06	20x10 ⁻⁷	0.75	0.96	0.72	0.2	51.5	39	3
□42	103F5505-7211	103F5505-7241	0.13	30x10 ⁻⁷	0.75	1.8	0.72	0.24	34	35	10
	103F5505-8211	103F5505-8241	0.13	30x10 ⁻⁷	1.4	0.55	0.72	0.24	34	35	10
	103F5508-7211	103F5508-7241	0.18	53x10 ⁻⁷	0.75	1.7	0.72	0.3	40	35	10
	103F5508-8211	103F5508-8241	0.18	53x10 ⁻⁷	1.4	0.63	0.72	0.3	40	35	10
	103F5510-7211	103F5510-7241	0.245	65x10 ⁻⁷	0.75	2.3	0.72	0.39	49	35	10
	103F5510-8211	103F5510-8241	0.25	65x10 ⁻⁷	1.4	0.8	0.72	0.39	49	35	10
	with Encoder	103F5510-72XE43	0.245	65x10 ⁻⁷	0.75	2.3	0.72	0.41	63.3	35	10
□60	103F7851-8211	103F7851-8241	0.55	275x10 ⁻⁷	1.4	0.74	0.72	0.62	46.5	111	15
	103F7852-8211	103F7852-8241	0.87	400x10 ⁻⁷	1.4	0.89	0.72	0.78	55	104	15
	103F7853-8211	103F7853-8241	1.67	840x10 ⁻⁷	1.4	1.5	0.72	1.4	87.5	85	20
		SF5601-9251	0.5	200x10 ⁻⁷	2.8	0.3	0.72	0.62	49	102	20
		SF5602-9251	0.83	310x10 ⁻⁷	2.8	0.37	0.72	0.8	60	97	20
		SF5603-9251	1.55	600x10 ⁻⁷	2.8	0.57	0.72	1.27	89	85	20
	with Encoder	103F7851-82XE42	0.55	275x10 ⁻⁷	1.4	0.74	0.72	0.64	61.5	111	15
	103F7852-82XE42	0.87	400x10 ⁻⁷	1.4	0.89	0.72	0.82	70.2	104	15	

*1 Load point: Position of 1/3 from the top of motor's output shaft.

(2) TAMAGAWA SEIKI CO., LTD.

Outside Dimensions (mm)	Model name		Maximum Holding Torque (N·m)	Rotor Inertia (Kg. m ²)	Current (A/phase)	D. C Resistance (Ω ±10%)	Step Angle (°)	Weight (kg)	Length (mm)	Allowable Radial Load (N) *1	Allowable Thrust Load (N)
	Both axes	Single axis									
□20	TS3682N11	TS3682N1	0.013	1.9x10 ⁻⁷	0.35	4.9	0.72	0.05	30	4.9	9.8
	TS3682N12	TS3682N2	0.024	4.0x10 ⁻⁷	0.35	9.1	0.72	0.085	46.5	4.9	9.8
□24	TS3664N11E2	TS3664N1E2	0.018	4.2x10 ⁻⁷	0.75	0.88	0.72	0.07	30.5	4.9	9.8
	TS3664N12E4	TS3664N2E4	0.028	8.3x10 ⁻⁷	0.75	1.36	0.72	0.12	46.5	4.9	9.8

*1 Load point: Position of 1/3 from the top of motor's output shaft.

3 – 2. General specifications

R2

(1) SANYO DENKI CO., LTD.

Item	Specification
Class of Insulation	Class B (+130°C)
Withstand Voltage	□28 AC500V 50/60Hz, for one minute
	□42, □60 AC1500V 50/60Hz, for one minute
Insulation Resistance	DC500V 100MΩ or more
Operating Ambient Temperature	-10°C~+50°C
	with Encoder -10°C~+40°C
Operating Ambient Humidity	20%~90%RH (no condensation allowed)
Motor surface temperature	100°C or less
	with Encoder 85°C or less

(2) TAMAGAWA SEIKI CO., LTD.

Item	Specification
Class of Insulation	Class B (+130°C)
Withstand Voltage	AC500V 60Hz, for one minute
Insulation Resistance	DC500V 100MΩ or more
Operating Ambient Temperature	-20°C~+50°C
Operating Ambient Humidity	5%~95%RH (no condensation allowed)
Motor surface temperature	90°C or less

(3) Encoder specifications

R2

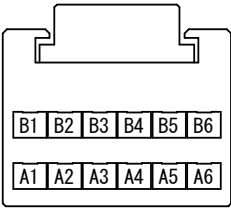
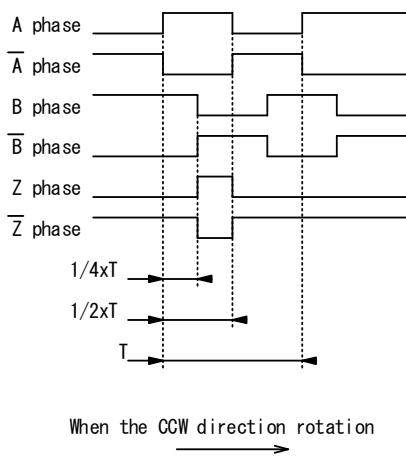
Item	Model name																																									
	103F5510-72XE43	103F7851-82XE42	103F7852-82XE42																																							
Supply Power	DC 5V \pm 5% input current 150mA																																									
Basic number of divisions	500 C/T																																									
Maximum response frequency	100 kHz																																									
Output Signal	Encoder outputs (A phase, B phase, Z phase) To the line driver output																																									
Connector (Encoder side)	Encoder Housing : 1-1318118-6 (Tyco Electronics) Contact : 1318106-1 (Tyco Electronics)																																									
	<table border="1"> <thead> <tr> <th>Pin No.</th> <th>Signal</th> <th>Lead color</th> </tr> </thead> <tbody> <tr><td>A1</td><td>A phase</td><td>Blue</td></tr> <tr><td>B1</td><td>\bar{A} phase</td><td>Brown</td></tr> <tr><td>A2</td><td>B phase</td><td>Green</td></tr> <tr><td>B2</td><td>\bar{B} phase</td><td>Violet</td></tr> <tr><td>A3</td><td>Z phase</td><td>White</td></tr> <tr><td>B3</td><td>\bar{Z} phase</td><td>Yellow</td></tr> <tr><td>A4</td><td>+5V</td><td>Red</td></tr> <tr><td>B4</td><td>GND</td><td>Black</td></tr> <tr><td>A5</td><td>N. C</td><td></td></tr> <tr><td>B5</td><td>N. C</td><td></td></tr> <tr><td>A6</td><td>Shield</td><td>Black</td></tr> <tr><td>B6</td><td>N. C</td><td></td></tr> </tbody> </table>	Pin No.	Signal	Lead color	A1	A phase	Blue	B1	\bar{A} phase	Brown	A2	B phase	Green	B2	\bar{B} phase	Violet	A3	Z phase	White	B3	\bar{Z} phase	Yellow	A4	+5V	Red	B4	GND	Black	A5	N. C		B5	N. C		A6	Shield	Black	B6	N. C		(Surface on which the contacts are inserted)	
Pin No.	Signal	Lead color																																								
A1	A phase	Blue																																								
B1	\bar{A} phase	Brown																																								
A2	B phase	Green																																								
B2	\bar{B} phase	Violet																																								
A3	Z phase	White																																								
B3	\bar{Z} phase	Yellow																																								
A4	+5V	Red																																								
B4	GND	Black																																								
A5	N. C																																									
B5	N. C																																									
A6	Shield	Black																																								
B6	N. C																																									
																																										
		● Adaptable connector <ul style="list-style-type: none"> • Housing : 1-1318115-6 • Contact : 1318112-1 • Manually operated crimping tool : 91576-1 (AWG28-24) 																																								
Timing																																										

- Please do not Insulation Resistance test and Insulated Withstanding Voltage test between the encoder signal line and frame.

3 – 3. Wiring diagram /Direction of rotation

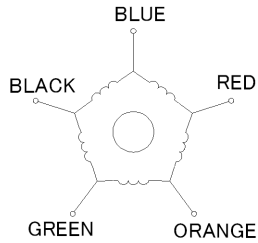

The direction of the rotation sees from installation face and is clockwise (CW).

		ENERGIZE ORDER									
		1	2	3	4	5	6	7	8	9	10
Lead color	BLUE			+	+	+			-	-	-
	RED	-	-			+	+	+			-
	ORANGE		-	-	-			+	+	+	
	GREEN	+			-	-	-			+	+
	BLACK	+	+	+			-	-	-		

• Please refer to each driver's instruction manual for details of the connection.

3 - 4. Dimensions

□20mm

Model name	L1	L2
TS3682N1	30	-
TS3682N11	30	8
TS3682N2	46.5	-
TS3682N12	46.5	8

(Unit : mm)

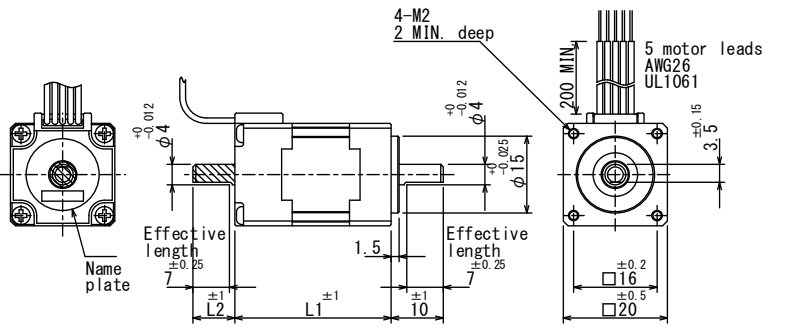

For single shaft models, ignore the shaft in the shaded areas.

□24mm

Model name	L1	L2
TS3664N1E2	30.5	-
TS3664N11E2	30.5	10
TS3664N2E4	46.5	-
TS3664N12E4	46.5	10

(Unit : mm)

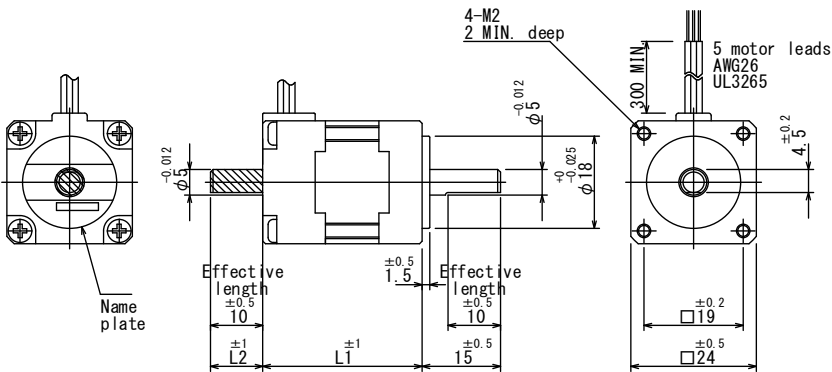

For single shaft models, ignore the shaft in the shaded areas.

□28mm

Model name	L1	L2
SH5281-3241	32	-
SH5281-3211	32	10
SH5285-3241	51.5	-
SH5285-3211	51.5	10
SH5281-7241	32	-
SH5281-7211	32	10
SH5285-7241	51.5	-
SH5285-7211	51.5	10
SH5281-7411	32	10
SH5285-7411	51.5	10

(Unit : mm)

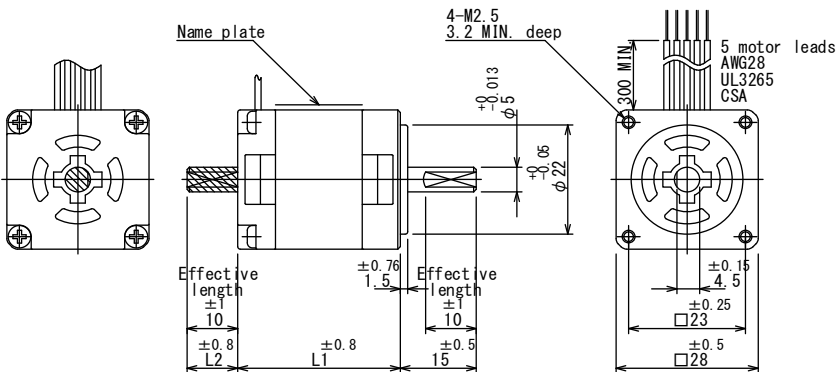

For single shaft models, ignore the shaft in the shaded areas.

5-PHASE STEPPING MOTOR Instructions Manual

R2

□42mm

Model name	L1	L2
103F5505-7241	34	-
103F5505-7211	34	15
103F5505-8241	34	-
103F5505-8211	34	15
103F5508-7241	40	-
103F5508-7211	40	15
103F5508-8241	40	-
103F5508-8211	40	15
103F5510-7241	49	-
103F5510-7211	49	15
103F5510-8241	49	-
103F5510-8211	49	15

(Unit : mm)

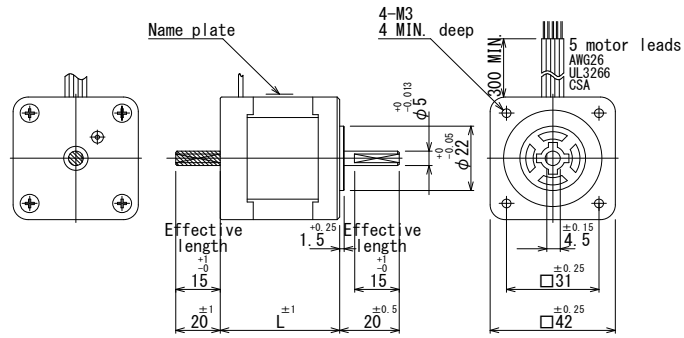

For single shaft models, ignore the shaft in the shaded areas.

□42mm with Encoder

Model name	L1
103F5510-72XE43	49

(Unit : mm)

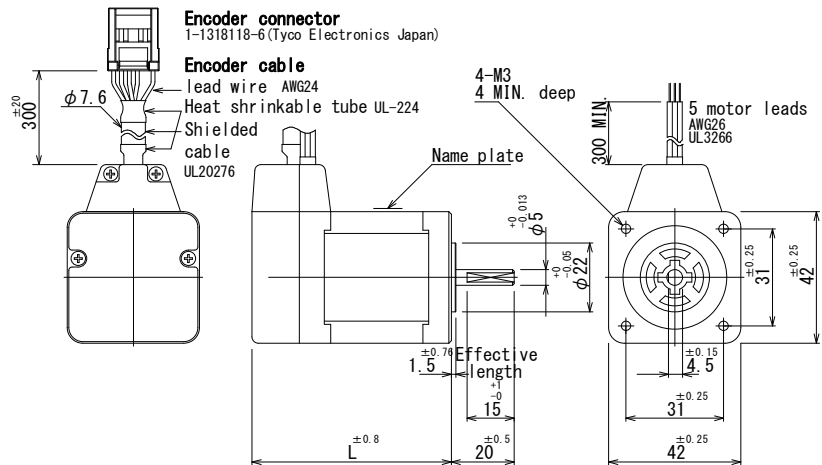

5-PHASE STEPPING MOTOR Instructions Manual

R2

□ 60mm

Model name	L1	L2
103F7851-8241	46.5	-
103F7851-8211	46.5	21
103F7852-8241	55	-
103F7852-8211	55	21
103F7853-8241	87.5	-
103F7853-8211	87.5	21

(Unit : mm)

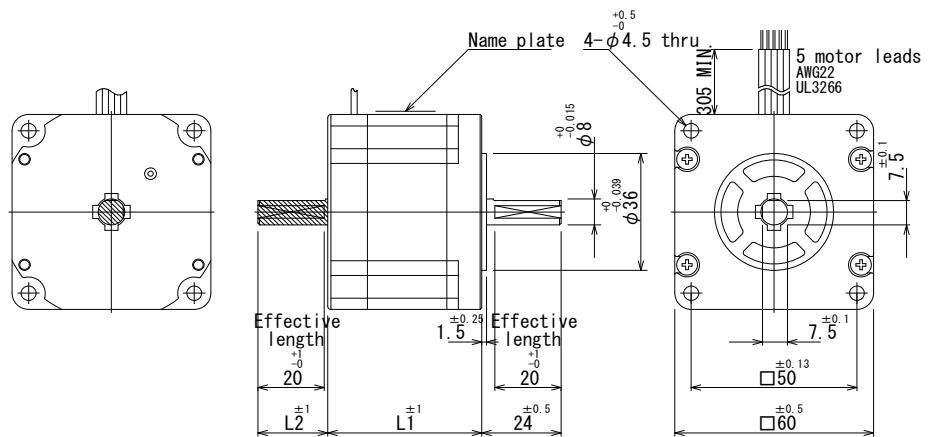

For single shaft models, ignore the shaft in the shaded areas.

□ 60mm

Model name	L1
SF5601-9251	49
SF5602-9251	60
SF5603-9251	89

(Unit : mm)

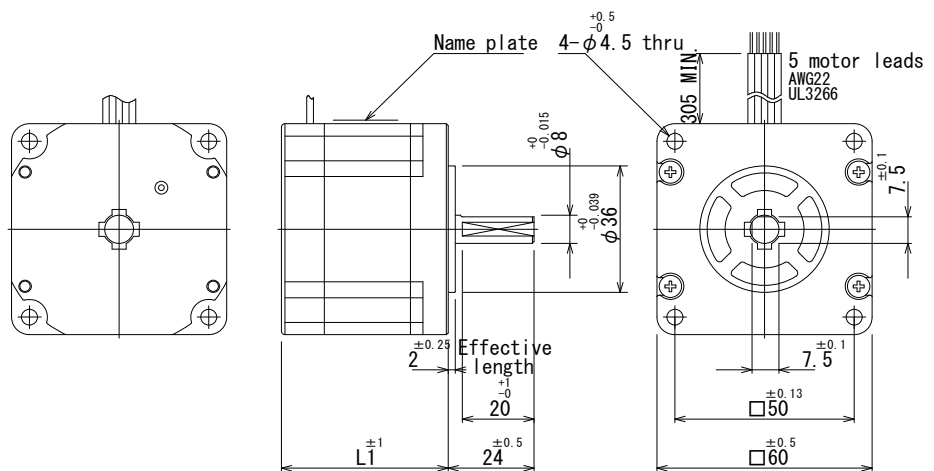

□60mm with Encoder

Model name	L1
103F7851-82XE42	61.5
103F7852-82XE42	70.2

(Unit : mm)

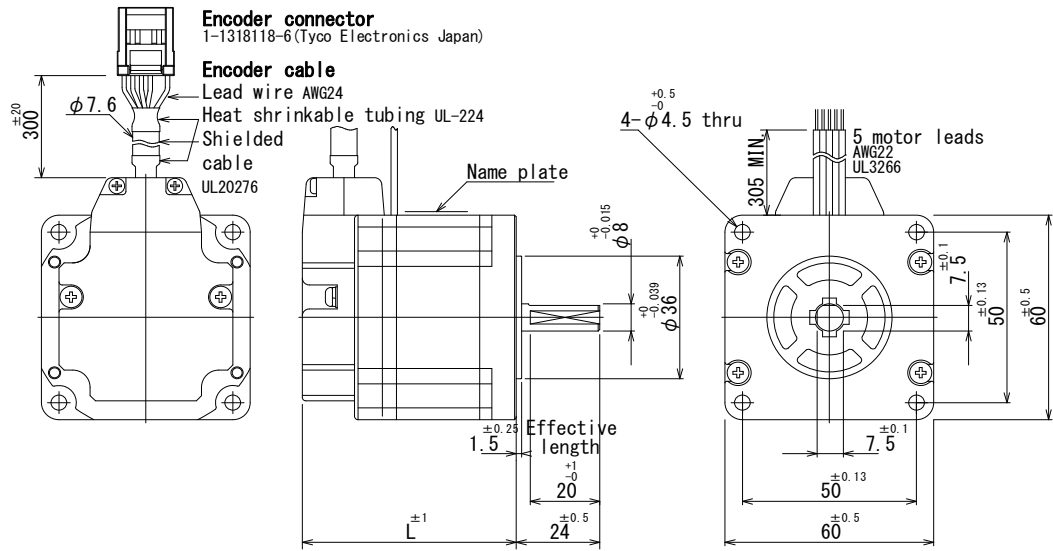

The main parts which revised by this manual

Parts	Content
P5, P6, P8, P9 P7	【R1】 ・ Deletion and addition of motor. ・ Withstand voltage of □28
P5 P5-P7A, P8-P9B P3, P5-P7A, P9, P9B P5, P6, P8, P9,	・ Deletion and addition of Motor-driver. ・ Added some motors. ・ Added Encoder specifications. ・ Corrected some mistakes.

Technical Service

TEL. (042) 664-5382 FAX. (042) 666-5664
E-mail s-support@melec-inc.com

Sales and Service

TEL. (042) 664-5384 FAX. (042) 666-2031
URL:<http://www.melec-inc.com>

Melec Inc. Control equipment marketing department
516-10, Higashiasakawa-cho, Hachioji-shi, Tokyo 193-0834, Japan

This Operating Manual is subject to change without prior notice
for the purpose of product improvement.

□□□□