

Melec



5-phase Stepping Motor Driver

ADB-5K30

Instructions Manual

(For designers' use)

USER'S MANUAL

Please ensure to read and understand this Instructions Manual before using the product. Please keep this Instructions Manual at hand so that it is always available for reference.

CE

MN0494

Introduction

This Instructions Manual describes the safe and proper method of handling "5-phase Stepping Motor Driver ADB-5K30" with emphasis on the specifications, assuming that our readers are engaged in designing of control devices incorporating stepping motors.

Please ensure to read and understand this Instructions Manual before using the product.

Please keep this Instructions Manual at hand so that it is always available for reference.

Descriptions in this manual on safety matters:

This product must be operated and used properly.

Otherwise, or when it is operated and used erroneously, unforeseen accidents may occur, causing physical injuries or property damages.

Majority of these accidents can be avoided if you are well informed of hazardous circumstances in advance.

Consequently, this instructions manual describes all the hazardous and dangerous circumstances and situations which can be foreseen and anticipated as well as necessary precautions.

All the above descriptions are being titled by the following symbol-marks and signal-words, namely:



Represents warnings ignorance of which can cause accidents involving fatal or serious physical injuries.



Represents cautions ignorance of which can cause accidents involving minor physical injuries or property damages.

Introduction

Descriptions in this manual on safety matters:

	CONTENTS	PAGE
1. Safety		
1-1. Safety precautions		6
1-2. Safety Information for Handling		7
2. Overview		
2-1. Characteristics		10
2-2. Product Configuration		10
2-3. Appearance		10
3. Name and Function of Each Section		
3-1. Signal I/O Connector (J1)		11
3-2. DC Input/Motor Output Connector (J2, J3)		12
3-3. POWER LED		12
3-4. O. H. A LED		12
3-5. Operating Section		13
4. Setting		
4-1. Setting STEP ANGLE SELECT switch		15
4-2. Setting HOLD CURRENT SELECT switch		16
4-3. Setting DRIVE CURRENT SELECT switch		17
4-4. Setting PULSE INPUT TYPE SELECT switch		18
4-5. Setting HOLD SWITCHING TIME SELECT switch		19
4-6. Setting ROTATE CHARACTERISTIC1 SELECT switch		20
4-7. Setting ROTATE CHARACTERISTIC2 SELECT switch		20
4-8. Setting EXTEND FUNCTION SELECT switch		21
5. Installation		
5-1. Conditions for Installation		22
5-2. Mounting Method		23
6. Connection		
6-1. Overview of Connection Configuration		24
6-2. Connecting Signal I/O Connector (J1)		25
6-3. Connecting DC Input/Motor Output Connector (J2, J3)		26
6-4. Inputting Power		28
7. Confirmation of Setting and Connection		
7-1. Check Points		29

	PAGE
8. Maintenance and Check-up	
8-1. Maintenance and Check-up	30
8-2. Troubleshooting	31
9. Storing and Disposal	
9-1. Storing	32
9-2. Disposal	32
10. Specifications	
10-1. General Specifications	33
10-2. I/O Signal	
(1) Example Circuit Connection	34
(2) Drive pulse input (CW, CCW)	35
(3) Motor excitation stop input (M.F)	36
(4) Phase signal output (P.O)	37
10-3. Overheat Alarm (O.H.A) LED	38
10-4. Dimensions	39
10-5. Applicable Motors	40
10-6. Torque Characteristics	41
10-7. Conforming to Europe standards	48

The main parts which revised by this manual

1. Safety

1 – 1. Safety Precautions

 WARNING
--

- (1) This product is not designed or manufactured for application for equipment requiring high level of reliability such as equipment related to nuclear energy, aeronautics-related equipment, automobiles, ships, medical appliances directly handling the human body and equipment that might seriously affect properties.
- (2) Do not use or keep the product in explosive or corrosive environments, in the presence of flammable gases, locations subjected to splashing water, fine particles, soot, steam, or exposed to radiation or direct sunshine. Doing so may cause injury or fire.
- (3) For the driver's power supply, use a DC power supply with reinforced insulation on its primary and secondary sides. Failure to do so may cause electric shock.
- (4) This product is designed for use within machinery, so it should be installed within an enclosure. Failure to do so may cause injury.
- (5) Do not transport, move, install the product, perform connections or inspections when the power is on. Doing so may cause electric shock, injury or fire.
- (6) Only qualified personnel are allowed to transport, move, install the product, perform connections or inspections. Failure to do so may cause injury or fire.

 CAUTION
--

- (7) Do not touch the driver during operation or immediately after stopping. Doing so may cause burn on the skin due to overheating of the driver.
- (8) Ensure to use this product according to the method specified in the Instructions Manual and within the specifications.
- (9) Depending on the operational conditions, the stepping motor may step out when it is on holding-state or driving-state. In particular, the load in transport may fall if the motor steps out on the vertical drive (such as the Z-axis). Start operation after test run for deliberate confirmation of operation.
- (10) Provide fail-safe measures so that the entire system may operate in a safe mode even in cases of the external power supply failure, disconnection of the signal line, or any failure on the driver.

1 – 2. Safety Information for Handling

●Overall:

 CAUTION

Do not touch the driver during operation or immediately after stopping. it may cause burn on the skin due to overheating of the driver.

●When setting up the STEP ANGLE SELECT switch:

 CAUTION

Erroneous setting may cause breakage of the machine or injury due to unexpected rotation of the motor. Ensure correct setting.

●When setting up the HOLD CURRENT SELECT switch:

 CAUTION

A high setting value may cause burn on the skin due to overheating of the motor. Do not select a high value beyond the required.

●When setting up the DRIVE CURRENT SELECT switch:

 CAUTION

A high setting value may cause burn on the skin due to overheating of the motor. Do not select a high value beyond the required.

- When setting up the PULSE INPUT TYPE SELECT switch:

⚠ CAUTION

Erroneous setting may cause breakage of the machine or injury due to unexpected rotation of the motor.
Ensure correct setting.

- When setting up the EXTEND FUNCTION SELECT switch:

⚠ CAUTION

Erroneous setting may cause breakage of the machine or injury due to unexpected rotation of the motor.
Ensure correct setting.

- When installing:

⚠ WARNING

Overheating may cause fire.
Mount it on a noncombustible member.
Keep it away from combustibles.

- When connecting the DC Input/ Motor Output Connectors (J2, J3):

⚠ CAUTION

Erroneous connection may cause breakage of the motor or the driver.
Correctly connect the DC Input/Motor output connector.

●When inputting power:

 CAUTION

Breakage of the machine or injury is apprehended due to unexpected behavior of the motor. Maintain the state where emergency stop is enabled at any time.

●When inputting the motor excitation stop (M.F) signal:

 CAUTION

Deterioration of the holding power with the motor may cause breakage of the machine or injury.
Check safety before inputting.

●When the overheat alarm (O.H.A) LED comes on:

 WARNING

Overheating may cause fire.
Stop operation when this LED comes on.

●When performing maintenance and checking:

 WARNING

Injury or fire is apprehended due to unexpected behavior.
Do not replace fuse.
Do not disassemble, repair or modify.

2. Overview

2-1. Characteristics

ADB-5K30 is a driver for a 5-phase stepping motor with DC +24V input.
 It can drive a 5-phase stepping motor with 0.35A/phase and 0.75A/phase.
 Step angles can be selected from six step angles ranging from 1 division to 40 division of the basic angle.
 HOLD CURRENT and DRIVE CURRENT can be set up.

- Applicable motors and setting for each motor are given in the table "10-5. Applicable Motors".

2-2. Product Configuration

- ADB-5K30 One unit(main frame)

J1, J2, J3 of the housing and the contact is not in accessories.

2-3. Appearance

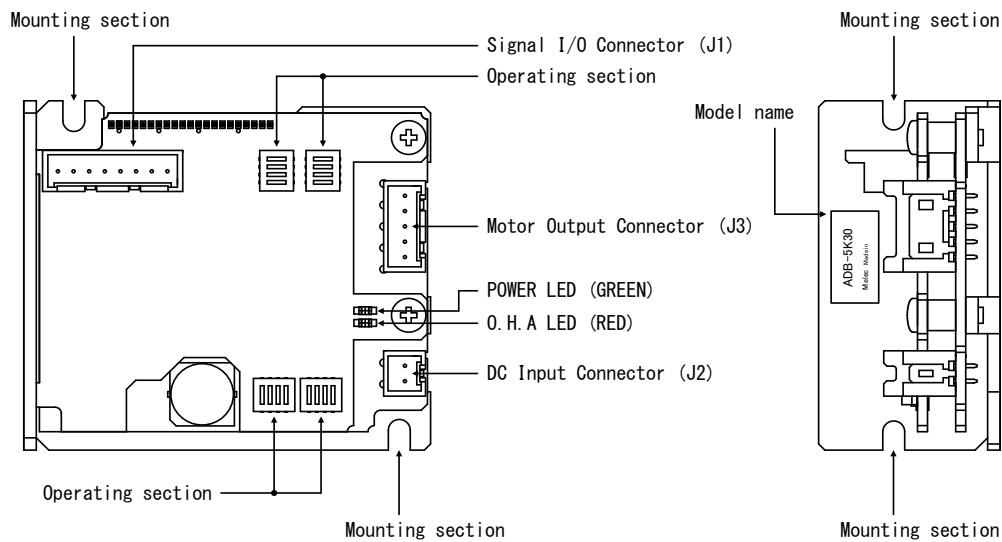

3. Name and Function of Each Section

3-1. Signal I/O Connector (J 1)

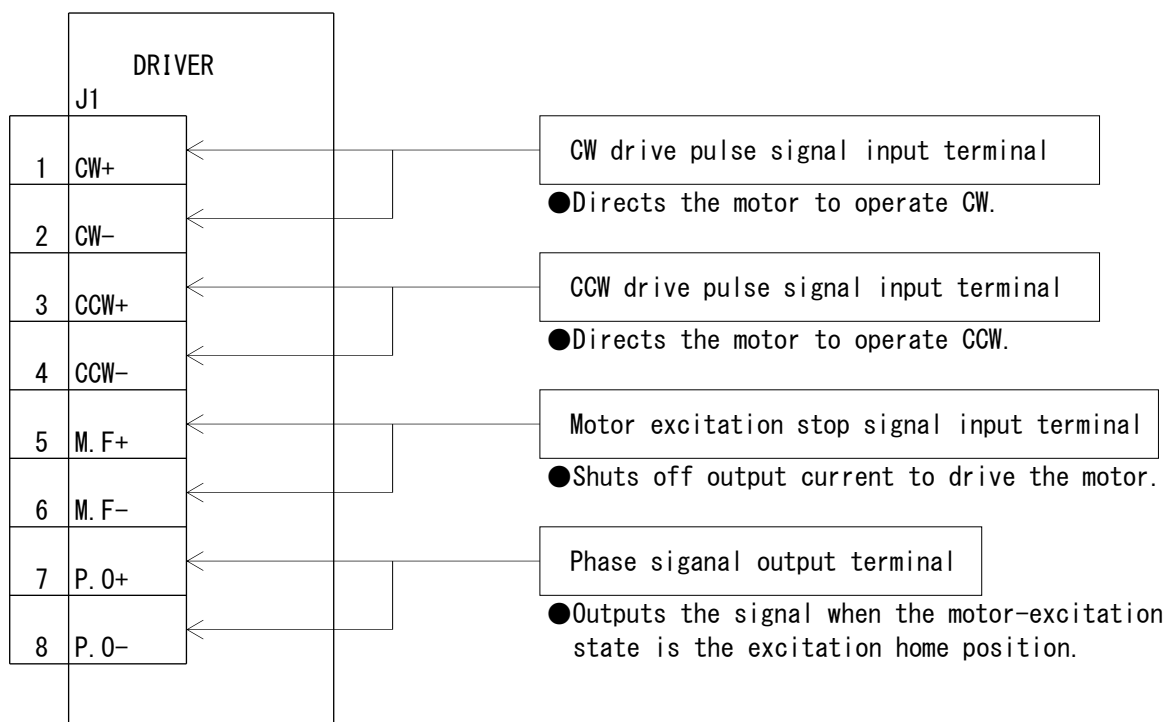

3 – 2. DC Input/Motor Output Connector (J 2, J 3)

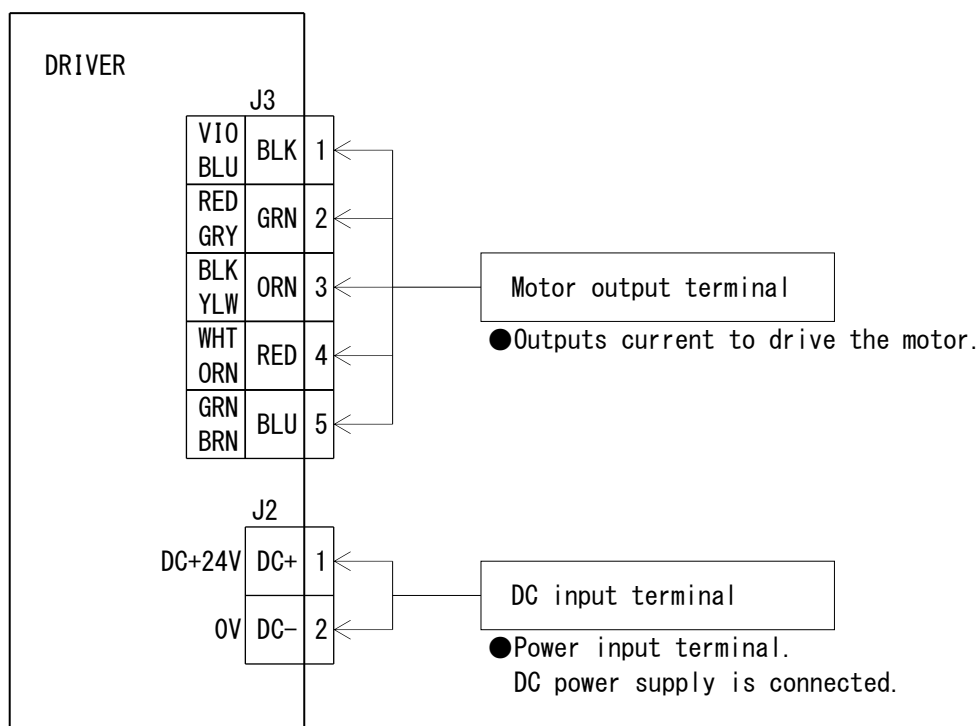

3 – 3. POWER LED

POWER LED (GREEN) comes on upon inputting power.

3 – 4. O. H. A LED

O. H. A LED (RED) comes on when internal temperature of the driver has reached approx. 70°C or more.

3 – 5. Operating Section

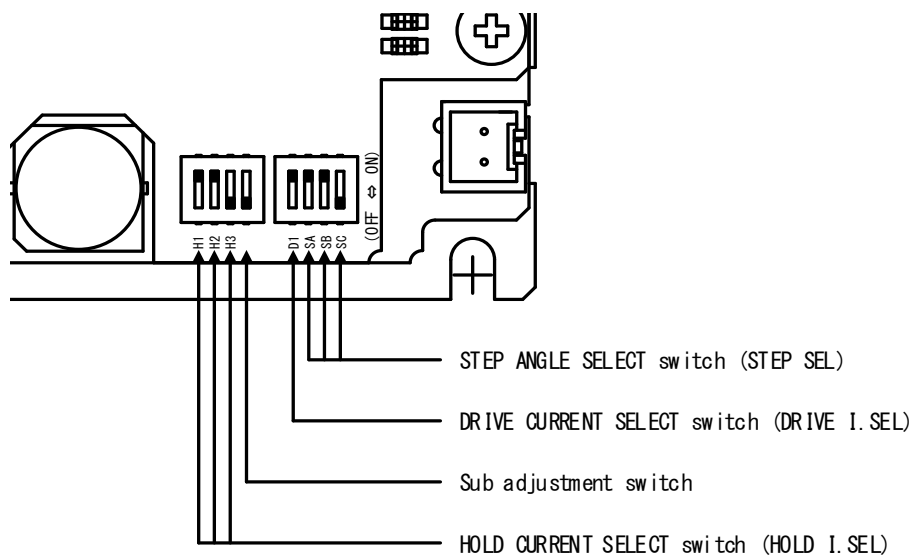

Name of Operating Section	Function	Factory Setting
4 STEP ANGLE SELECT switch	Select a step angle.	SC: [OFF]
3 STEP ANGLE SELECT switch		SB: [ON]
2 STEP ANGLE SELECT switch		SA: [ON]
1 DRIVE CURRENT SELECT switch	Select DRIVE CURRENT.	D1: [ON]
4 Sub adjustment switch	Use it with OFF.	[OFF]
3 HOLD CURRENT SELECT switch	Select HOLD CURRENT.	H3: [OFF]
2 HOLD CURRENT SELECT switch		H2: [ON]
1 HOLD CURRENT SELECT switch		H1: [ON]

Instructions Manual

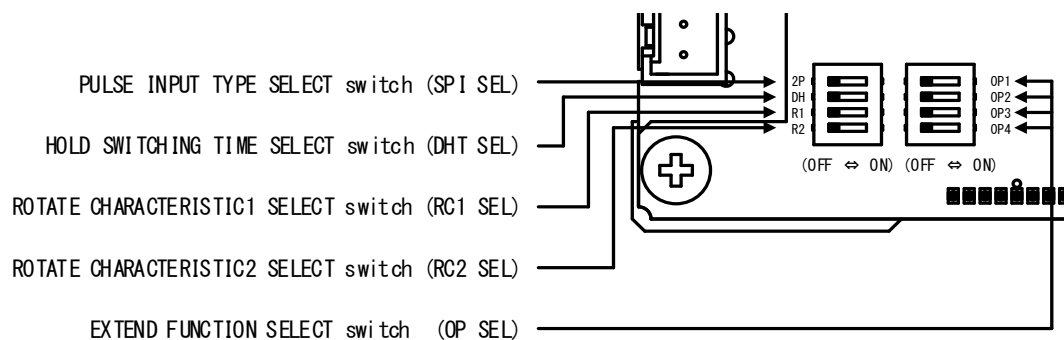

Name of Operating Section	Function	Factory Setting
1 PULSE INPUT TYPE SELECT switch	Select a pulse input type.	2P: [OFF]
2 HOLD SWITCHING TIME SELECT switch	DRIVE/HOLD CURRENT automatic switching time is selected.	DH: [OFF]
3 ROTATE CHARACTERISTIC1 SELECT switch	Use it with OFF.	R1: [OFF]
4 ROTATE CHARACTERISTIC2 SELECT switch	Use it with OFF.	R2: [OFF]
1 EXTEND FUNCTION SELECT switch	Select EXTEND FUNCTION.	OP1: [OFF]
2 EXTEND FUNCTION SELECT switch	Select EXTEND FUNCTION.	OP2: [OFF]
3 EXTEND FUNCTION SELECT switch	Select EXTEND FUNCTION.	OP3: [OFF]
4 EXTEND FUNCTION SELECT switch	Select EXTEND FUNCTION.	OP4: [OFF]

4. Setting

4 – 1. Setting STEP ANGLE SELECT switch

 **CAUTION**

Erroneous setting may cause breakage of the machine or injury due to unexpected rotation of motor.
Ensure correct setting.

The step angle is set up with the STEP SEL switch.
The step angle can be selected from six different types of step angles.

- (1) Set the step angle required by the STEP SEL switch [SA, SB, SC].

- Relationship between the STEP SEL switch and the step angle.

STEP SEL switch			1/ Divisions	Step angle(°) 0.72° motor	
SC	SB	SA			
ON	ON	ON	1/1	0.72°	
ON	ON	OFF	1/2	0.36°	
ON	OFF	ON	1/4	0.18°	
ON	OFF	OFF	1/10	0.072°	
OFF	ON	ON	1/20	0.036°	(Factory setting)
OFF	ON	OFF	1/40	0.018°	
OFF	OFF	ON	-	-	
OFF	OFF	OFF	-	-	(Sub adjustment (Not available))

4 – 2. Setting HOLD CURRENT SELECT switch

CAUTION

A high setting value may cause burn on the skin due to overheating of the motor.
Do not select a high value beyond the required.

HOLD CURRENT is set up with the HOLD I.SEL switch.
The ratio of HOLD CURRENT to DRIVE CURRENT can be selected.

(1) Set the HOLD I.SEL switch to the ratio of HOLD CURRENT to DRIVE CURRENT required.

● Ratio of HOLD CURRENT

$$\text{Ratio of HOLD CURRENT (\%)} = \frac{\text{HOLD CURRENT}}{\text{DRIVE CURRENT}} \times 100$$

HOLD I.SEL switch			Ratio of HOLD CURRENT (%)
H3	H2	H1	
OFF	OFF	OFF	–
OFF	OFF	ON	20
OFF	ON	OFF	30
OFF	ON	ON	40
ON	OFF	OFF	50
ON	OFF	ON	60
ON	ON	OFF	70
ON	ON	ON	100

(Factory setting)

● HOLD CURRENT changes relative to DRIVE CURRENT setting.

The ratio of HOLD CURRENT [100%] represents the same as the setting for DRIVE CURRENT.

● The greater the ratio of HOLD CURRENT grows, the more heat the motor generates when is on holding-state.

4 – 3. Setting DRIVE CURRENT SELECT switch

⚠ CAUTION

A high setting value may cause burn on the skin due to overheating of the motor.
Do not select a high value beyond the required.

DRIVE CURRENT is set up with the DRIVE I.SEL switch.

- (1) Set the DRIVE I.SEL switch to the setting specified in the table "10-5. Applicable Motors."

● Relationship between the DRIVE I.SEL switch and DRIVE CURRENT.

DRIVE I.SEL switch	A/phase
D1	
OFF	0.35
ON	0.75 (Factory setting)

4 – 4. Setting PULSE INPUT TYPE SELECT switch

CAUTION

Erroneous setting may cause breakage of the machine or injury due to unexpected rotation of the motor.
Ensure correct setting.

Pulse input method is set up with the SPI SEL switch.
Set this switch with power OFF.

- (1) Turn power [OFF].
- (2) Set the SPI SEL [2P/1P] switch.

SPI SEL	Input type
ON	1 PULSE (1P)
OFF	2 PULSE (2P)

(Factory setting)

- When the motor is operated with two pulse signal inputs of CW and CCW, set the SPI SEL switch to [OFF(2P)].
- When the motor is operated with the pulse signal and direction signal input, set the SPI SEL switch to [ON(1P)].
- In the case that 1-pulse input method is selected, the CCW terminal becomes direction signal input designating the direction of the motor rotation. Drive pulse set to the CW terminal (CW+, CW-).

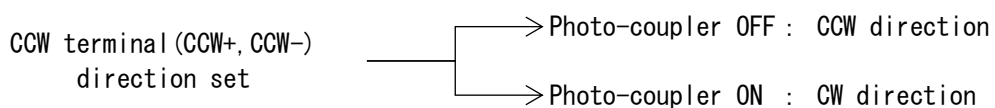

- The input timing is same with 2-pulse input method and 1-pulse input method. As for input timing, refer to "10-2. (2) Drive pulse input (CW, CCW)"

4 – 5. Setting HOLD SWITCHING TIME SELECT switch

DRIVE/ HOLD CURRENT automatic switching time is set up with the DHT SEL switch.

(1) Set the DHT SEL switch.

DHT SEL	DRIVE/ HOLD Switching Time
ON	15ms
OFF	150ms

(Factory setting)

4 – 6. Setting ROTATE CHARACTERISTIC1 SELECT switch

Set this switch with power OFF.

- (1) Use it with [OFF].

4 – 7. Setting ROTATE CHARACTERISTIC2 SELECT switch

Set this switch with power OFF.

- (1) Use it with [OFF].

4 – 8. Setting of the EXTEND FUNCTION SELECT switch

CAUTION

Erroneous setting may cause breakage of the machine or injury due to unexpected rotation of motor.
Ensure correct setting.

Set this switch with power OFF.

- (1) Turn power [OFF].
- (2) Set the functions required by the OP SEL switch.

OP SEL switch				Function allocation
OP4	OP3	OP2	OP1	
OFF	OFF	OFF	OFF	–
OFF	OFF	OFF	ON	–
OFF	OFF	ON	OFF	–
OFF	OFF	ON	ON	–
OFF	ON	OFF	OFF	–
OFF	ON	OFF	ON	–
OFF	ON	ON	OFF	–
OFF	ON	ON	ON	–
ON	OFF	OFF	OFF	–
ON	OFF	OFF	ON	–
ON	OFF	ON	OFF	–
ON	OFF	ON	ON	–
ON	ON	OFF	OFF	–
ON	ON	OFF	ON	–
ON	ON	ON	OFF	–
ON	ON	ON	ON	Sub adjustment (Not available)

(Factory setting)

5. Installation

5-1. Conditions for Installation

⚠ WARNING

Overheating may cause fire.
Mount it on a noncombustible member.
Keep it away from combustibles.

- (1) Designed for incorporating into equipment used indoors, this product requires to be installed in the following environment:
- Indoors (where it is not exposed to direct sun).
 - Where ambient temperature and humidity are controlled within the range set out in the specifications.
 - Where there is no explosive, corrosive or inflammable gas.
 - Where it can be protected from dust, salt or iron powder.
 - Where the product main frame is not exposed to direct vibration or shock.
 - Where it is not exposed to splashes of water, oil or chemicals.
- (2) Install the driver at least 5mm away from other equipment.
However, please be installed to a distance of at least 15mm from the heating element.

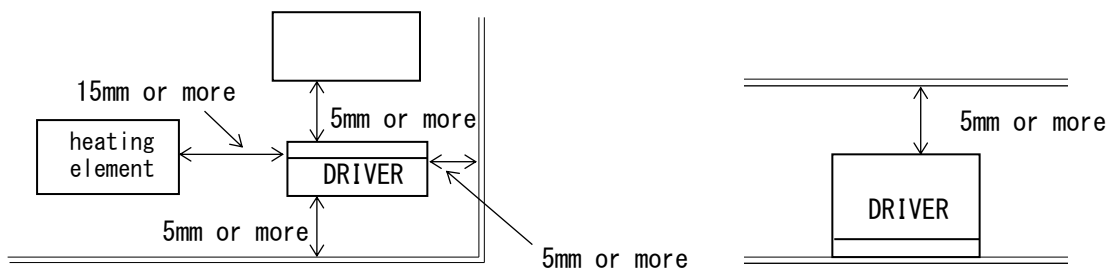

- Please contact us if you are not installed to a distance of at least 15mm from the heating element.

- (3) Take measures against accumulation of heat such as allowing generous space around the driver or installing a fan so that heat release is taken care of.
- (4) In the case that the overheat alarm signal is output, perform the cooling measure of compulsion air cooling etc.
Use the driver on the condition that the overheat alarm signal is not output.
- (5) Do not allow standing or placing anything heavy on the product.

5 – 2. Mounting Method

The round holes on the main frame are used.

The following items are required:

- M-3 screw (8mm or more in length): ----- 2
- M-3 spring washer: ----- 2
- M-3 flat washer: ----- 2

(1) Fix the product at the two round holes on the main frame.

● Mounting example

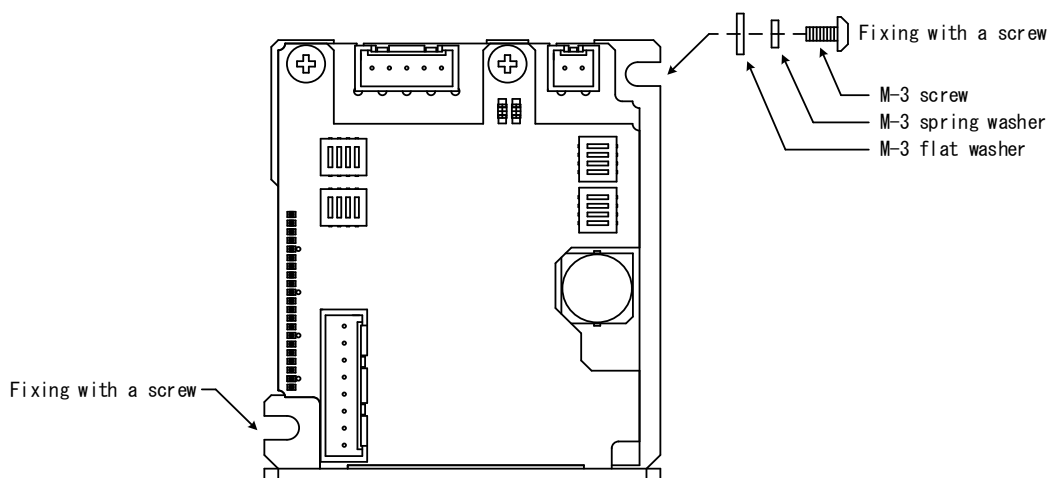
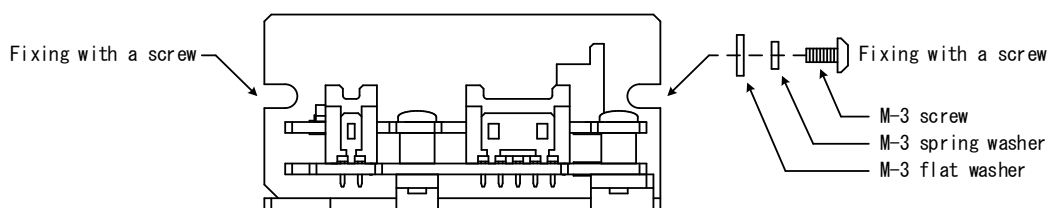

6. Connection

6-1. Overview of Connection Configuration

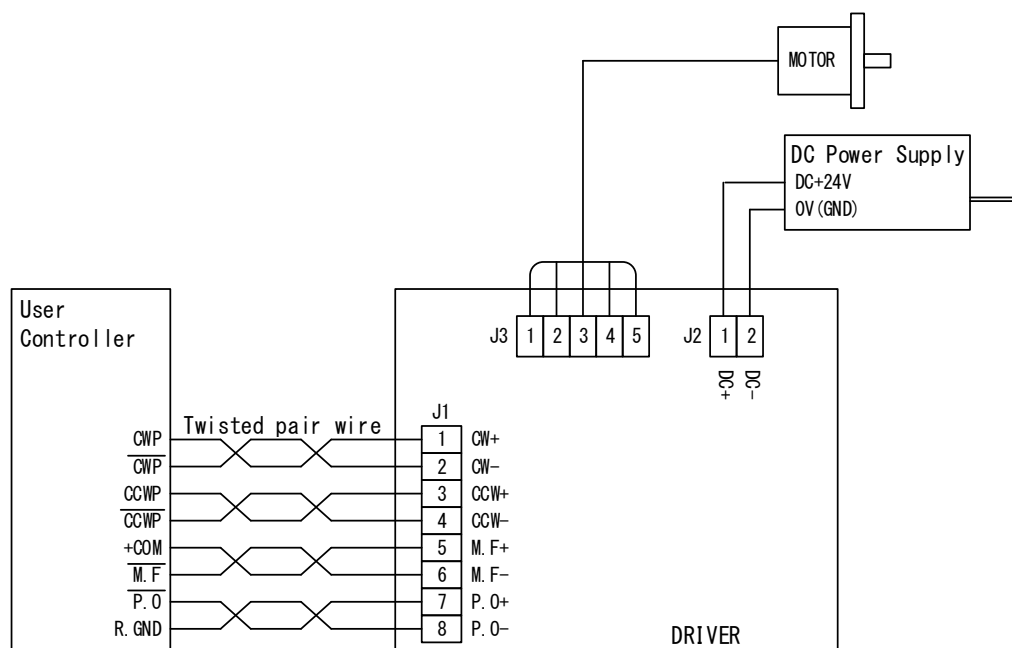

- Connect only one motor to one driver.
- Use twisted pair wire for the CW/CCW input signal line.
- Provide shielding for the signal line where considerable noise is generated.
- Use the wire material of the characteristic that is difficult to burn.
- For the driver's power supply, use a DC power supply with reinforced insulation on its primary and secondary sides.

[Example configuration]

The metallic enclosure and shielded wires work to shield noise.

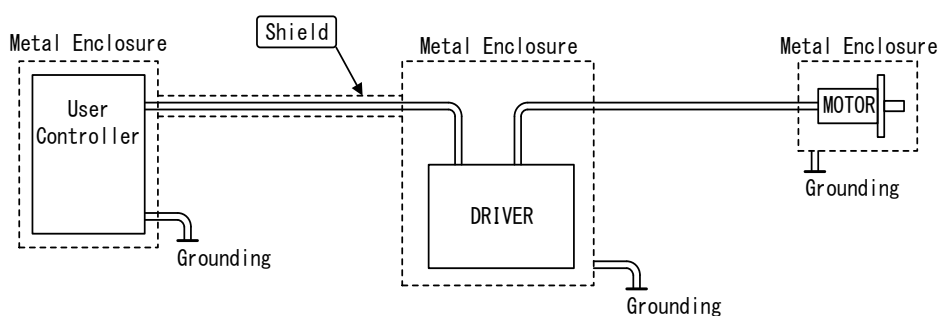

6 – 2. Connecting Signal I/O Connector (J 1)

The following items are required:

- Housing for J1 (51103-0800:Molex) One unit
- Contact for J1 (50351-8100:Molex) 8 contacts
- Manually operated crimping tool for AWG28-22 (57295-5000:Molex) One unit

- (1) Crimp the contact to the cable used for wiring.
- (2) Insert the contact into the housing.
Make sure that the housing No. and the connector No. on the main frame are matched before inserting the contacts.
- (3) Connect the housings to the connectors on the main frame.
 - The contacts for J1 are 8 pieces.
 - When inserting, keep pushing J1 housing into the connectors until it is locked. Also, check if the contacts are not displaced from the housing.
 - In wiring, isolate the J1 signal lines from equipment that may be a source of noise, the power line and the motor line.

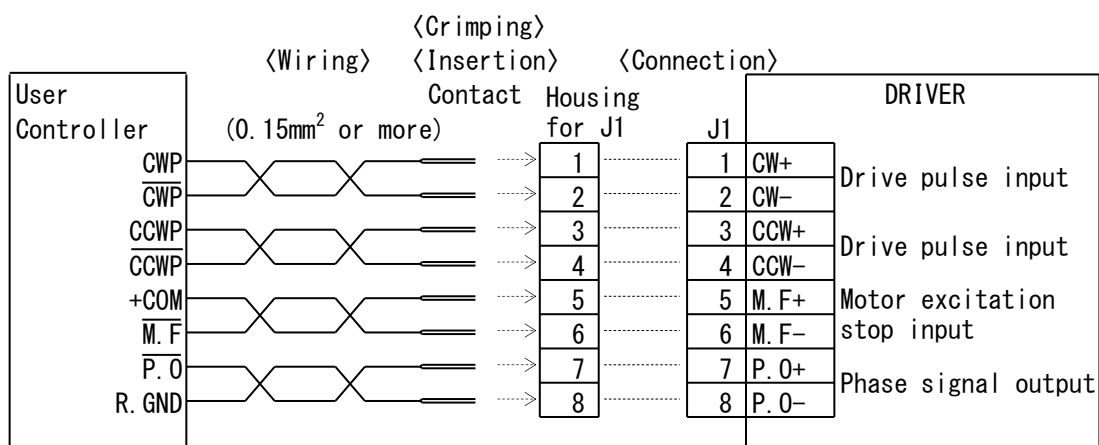
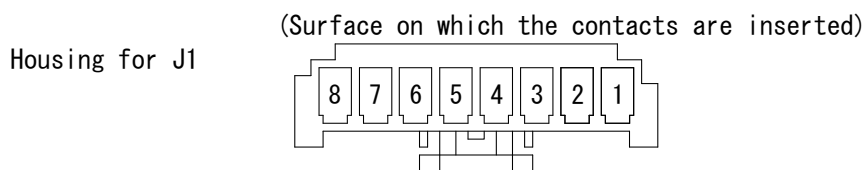

6 – 3. Connecting DC Input/Motor Output Connector (J 2, J 3)

 CAUTION
Erroneous connection may cause breakage of the motor or the driver. Correctly connect the DC Input/Motor output connector.

The following items are required:

- Housing for J2 (51103-0200:Molex) One unit
- Housing for J3 (51103-0500:Molex) One unit
- Contact for J2, J3 (50351-8100:Molex) 7 contacts
- Manually operated crimping tool One unit
for AWG28-22 (57295-5000:Molex)

- (1) Crimp the contact to the cable used for wiring.
- (2) Insert the contact into the housing.
Make sure that the housing No. and the connector No. on the main frame are matched before inserting the contacts.
- (3) Connect the housings to the connectors on the main frame.
 - The contacts for J2 (for DC input) are 2 pieces, and for J3 (motor output) are 5 pieces.
 - When inserting, keep pushing J2, J3 housings into the connectors until it is locked. Also, check if the contacts are not displaced from the housing.

(Surface on which the contacts are inserted)

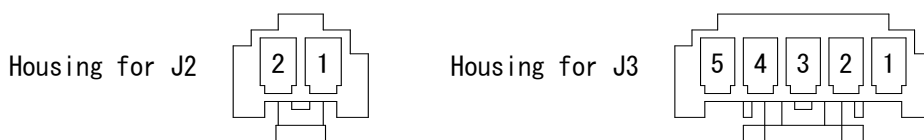

[DC input Connector]

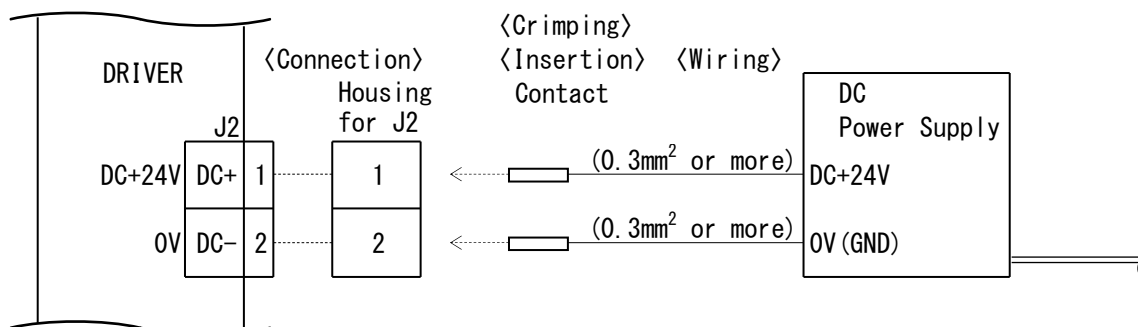

[Motor output Connector]

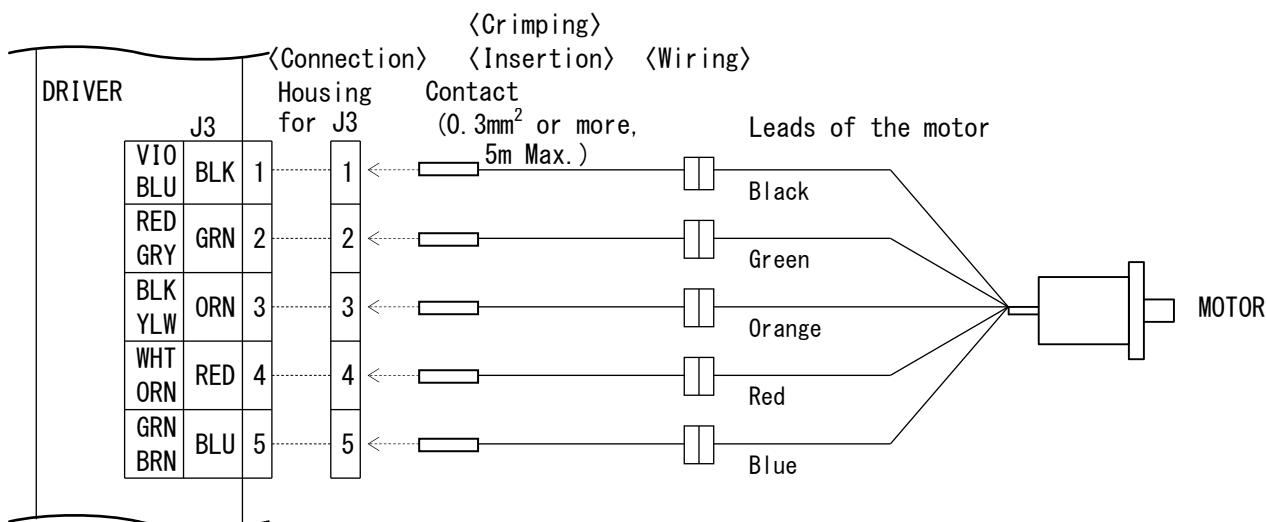
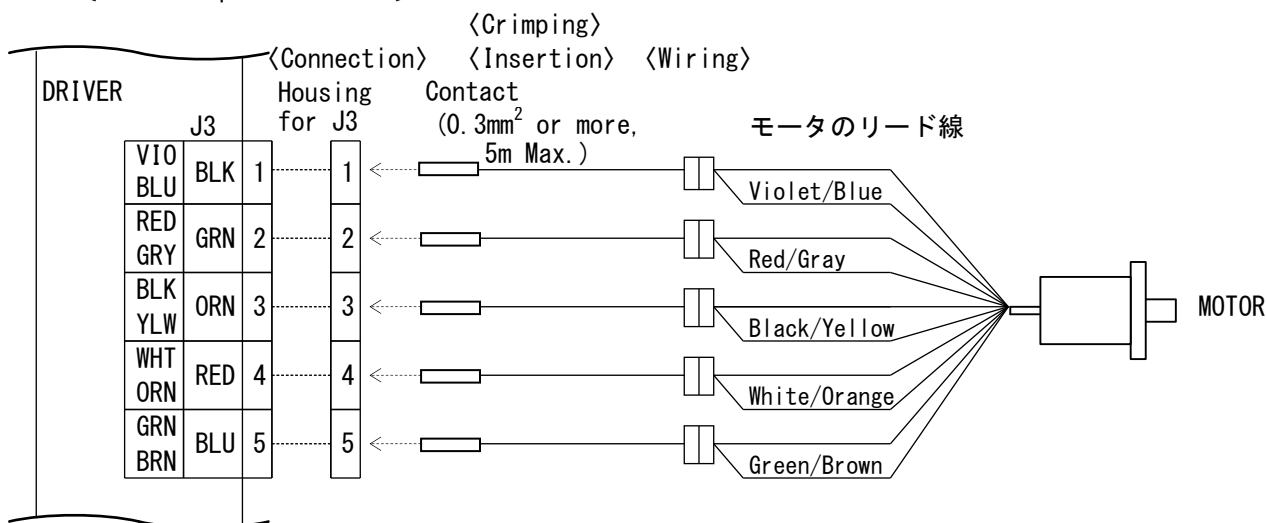

● Color indications for the motor crimping J3 represent colors of the leads of the motor.

● Use a cable of 5m or less for the motor cable.

6 – 4. Inputting Power

⚠ CAUTION

Breakage of the machine or injury is apprehended due to unexpected behavior of the motor. Maintain the state where emergency stop is enabled at any time.

- (1) Input the DC power supply (DC+24V) in the cable that connected to No.1 and No.2 terminals of J2.

① Timing chart

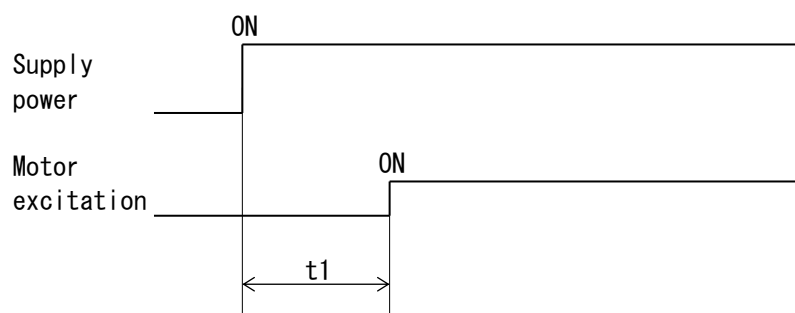

$t1 \leq 300\text{ms}$ ($t1$: Time required for the motor to be enabled.)

7. Confirmation of Setting and Connection

7-1. Check Points

This product requires different switch setting and motor wiring depending on the motor used.

Check if the switch setting and the motor wiring are correctly performed.

Check Points		Check	Remarks
Setting of PULSE INPUT TYPE SELECT switch	SPI SEL (1P/2P)		
Setting of HOLD SWITCHING TIME SELECT switch	DHT SEL (ON/OFF)		
Setting of STEP ANGLE SELECT switch	STEP SEL (SA, SB, SC)		
Setting of DRIVE CURRENT SELECT switch	DRIVE I. SEL (ON/OFF)		
Setting of HOLD CURRENT SELECT switch	HOLD I. SEL (H1, H2, H3)		
Setting of ROTATE CHARACTERISTIC1 SELECT switch	RC1 SEL (OFF)		
Setting of ROTATE CHARACTERISTIC2 SELECT switch	RC2 SEL (OFF)		
Setting of EXTEND FUNCTION SELECT switch	OP SEL (OP4, OP3, OP2, OP1)		
Connection of J1			
Connection of J2	DC+, DC-		
Connection of J3	MOTOR		

8. Maintenance and Check-up

8 – 1. Maintenance and Check-up

 **WARNING**

Injury or fire is apprehended due to unexpected behavior.
Do not replace fuse.
Do not disassemble, repair or modify.

- (1) As for maintenance inspections the engineer of the specialty shall do it.
- (2) We recommend that the following check-ups should be performed periodically:
 - Checking for any loosened contact on the connectors.
 - Checking for any flaw and crack on the cabling.
- (3) In case of failure, return the driver to us and have it repaired.

8 – 2. Troubleshooting

Trouble	Check Item	Assumed Cause
1. POWER LED does not come on.	<ul style="list-style-type: none"> • Connection of power supply. • Value of power voltage. 	<ul style="list-style-type: none"> • Wiring error with power supply. • Power voltage failure. • Driver failure.
2. The motor is not excited. (It can be easily rotated by hand.)	<ul style="list-style-type: none"> • Connection of the motor to the driver. • ON/OFF status of the M.F signal. • Value of the HOLD CURRENT SELECT switch. 	<ul style="list-style-type: none"> • Wiring error with the motor and the driver. • The M.F signal is input. • The setting for HOLD CURRENT is too low. • Driver failure.
3. The motor does not rotate. The motor behaves abnormally. The motor steps out.	<ul style="list-style-type: none"> • The same check items as those under item 2 above. • Setting of the PULSE INPUT TYPE SELECT switch. • Connection of the pulse signal. • Voltage and wave form of the pulse signal. • Setting of the DRIVE CURRENT SELECT switch. • Setting of the STEP ANGLE SELECT switch. • Setting of the ROTATE CHARACTERISTIC1 SELECT switch. • Setting of the ROTATE CHARACTERISTIC2 SELECT switch. • Setting of the EXTEND FUNCTION SELECT switch. 	<ul style="list-style-type: none"> • Wrong setting for the pulse input type. • Wiring error with the pulse signal line. • Pulse signal of wrong specifications. • DRIVE CURRENT is too low. • Wrong setting for the step angle. • Wrong setting for the ROTATE CHARACTERISTIC1 selection. • Wrong setting for the ROTATE CHARACTERISTIC2 selection. • Wrong setting for the EXTEND FUNCTION selection. • Driver failure. • Motor failure.
4. The motor steps out during acceleration.	<ul style="list-style-type: none"> • Starting pulse speed. • Acceleration time. 	<ul style="list-style-type: none"> • Starting pulse signal speed is too high. • Acceleration time is too short.
5. The motor generates excessive heat.	<ul style="list-style-type: none"> • Setting of the DRIVE CURRENT SELECT switch. • Value of the HOLD CURRENT SELECT switch. 	<ul style="list-style-type: none"> • DRIVE CURRENT is higher than the setting for the applicable motor. • The setting for HOLD CURRENT is too high.

Short-circuiting of the motor output connector may cause the driver to fail.

- The motor output connector and the power line.
- The motor output connector and the motor output connector.

When the failure phenomenon cannot be remedied, contact our office.

9. Storing and Disposal

9 – 1. Storing

(1) Keep the product in the following environment:

- Indoors (where it is not exposed to direct sun).
- Where ambient temperature and humidity are controlled within the range set out in the specifications.
- Where there is no explosive, corrosive or inflammable gas.
- Where it can be protected from dust, salt or iron powder.
- Where the product main frame is not exposed to direct vibration or shock.
- Where it is not exposed to splashes of water, oil or chemicals.

(2) Do not allow standing or placing anything heavy on the product.

9 – 2. Disposal

(1) Dispose of the product as industrial waste.

1 0. Specifications

1 0 – 1. General Specifications

Supply Power	DC+24V *1 (Ripple voltage P-P 2.0V or less) ●Rated input current : [DRIVE I.SEL ⇒ ON set up] at DRIVE DC+24V: 1.5A *2 ●Rated input current : [HOLD I.SEL ⇒ Approx. 40% set up] at HOLD DC+24V: 0.3A	
Motor output current	●DRIVE CURRENT 0.35A/phase or 0.75A/phase ●HOLD CURRENT Approx. 40% of DRIVE CURRENT (factory-set)	
Input Signal	●Drive pulse input (CW, CCW) ----- Photo-coupler input ●Motor excitation stop input (M.F) ----- Photo-coupler input	
Output Signal	●Phase signal output (P.0) ----- 0/C output	
Functions of Operating Sections	●Step angle selection (STEP SEL) ●HOLD CURRENT selection (HOLD I.SEL) ●DRIVE CURRENT selection (DRIVE I.SEL) ●PULSE INPUT TYPE selection (SPI SEL) ●HOLD switching time selection (DHT SEL) ●ROTATE CHARACTERISTIC1 SELECT switch (RC1 SEL) ●ROTATE CHARACTERISTIC2 SELECT switch (RC2 SEL) ●EXTEND FUNCTION SELECT switch (OP SEL)	
Overheat alarm	●Overheat alarm LED (O.H.A LED)	
Operating Ambient Temperature	0°C ~ +50°C (No freezing allowed.)	
Operating Ambient Humidity	80%RH or less (No condensation allowed.)	
Storing Temperature	-10°C ~ +60°C (No freezing allowed.)	
Storing Humidity	80%RH or less (No condensation allowed.)	
Altitude	Up to 1000m above sea level	
Atmosphere	Indoor (Exposure to direct sun is not allowed.) Without any explosive, corrosive or inflammable gas, oil mist, or dust.	
Withstanding Vibration	No abnormality should be found after a vibration test at 10~55Hz, 0.15mm P-P	
Insulation resistance	DC connector - signal connector - Frame (Each other)	DC500V 100MΩ or more
Exterior Dimensions	W57 × H65 × D29 (mm)	
Weight	0.07 kg	

*1 Input voltage range is DC+24V±10%.

*2 Use a power supply that provides sufficient input current.

1 0 – 2. I/O Signal

(1) Example Circuit Connection

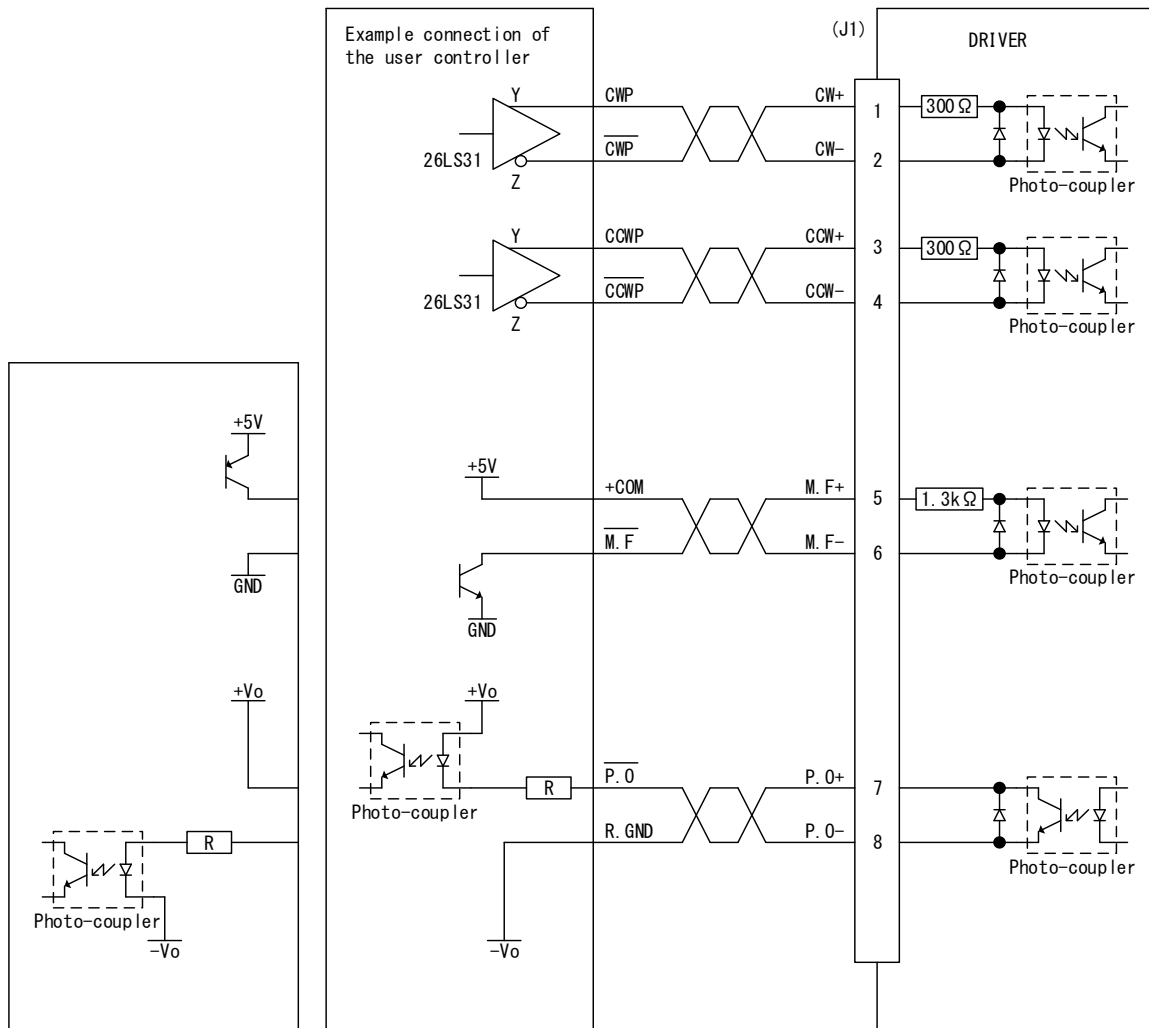

(2) Drive pulse input (CW, CCW)

- ① Operating current range : 5mA~14mA
The photo-coupler turns on with inter-terminal voltage of 3.1V~5.5V. (Photo-coupler diode $V_F \doteq 1.5V$)

② Timing chart

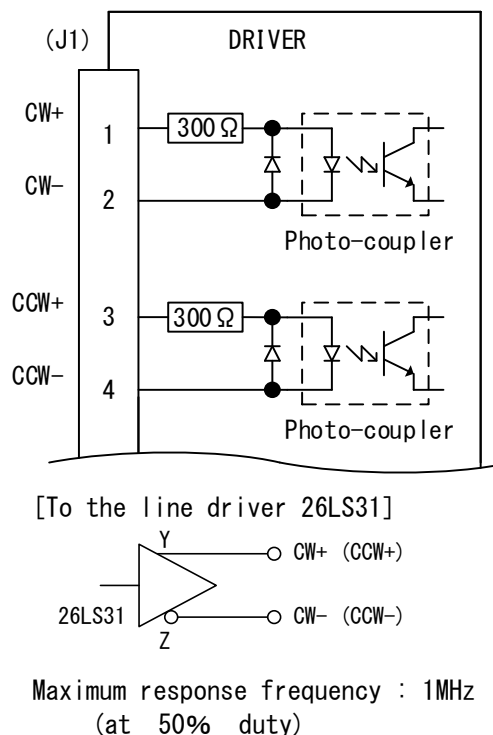
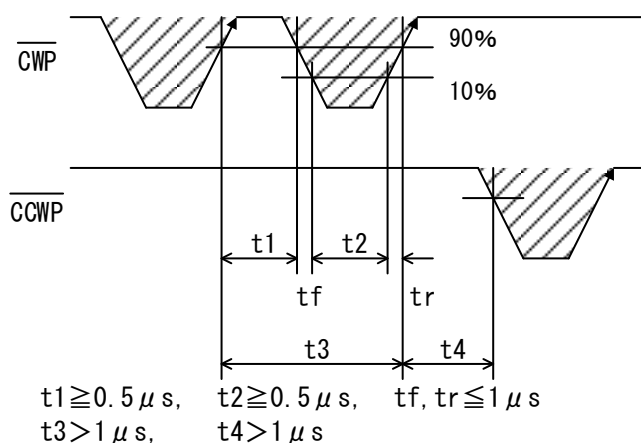

- The shaded area (///) indicates light emission from the photo-coupler, and the motor is driven at the rising edge (↗).
"t4" greatly varies according to the inertial moment including that of the motor.

③ Automatic switching for DRIVE/HOLD

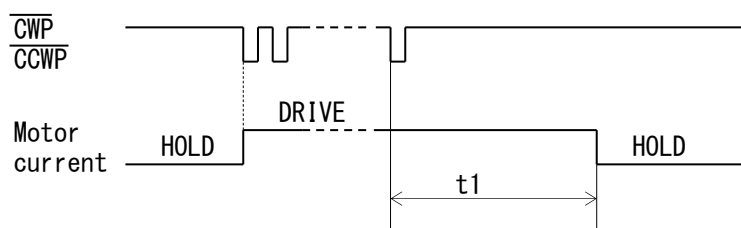

$t1 \doteq 15ms$ (HOLD SWITCHING TIME SELECT switch : ON)
 $t1 \doteq 150ms$ (HOLD SWITCHING TIME SELECT switch : OFF)

- Inputting drive pulse causes the current output to the motor to change from HOLD CURRENT to DRIVE CURRENT, which returns to HOLD CURRENT in about "t1". DRIVE CURRENT continues if pulse is input on driving-state.

④ Direction of rotation

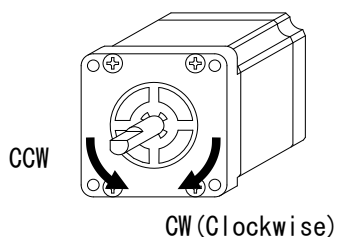

(3) Motor excitation stop input (M.F)

CAUTION

Deterioration of the holding power with the motor may cause breakage of the machine or injury.
Check safety before inputting.

- ① Operating current range : 2.6mA~19.5mA
The photo-coupler turns on with inter-terminal voltage of 4.5 V~26.4 V.
(Photo-coupler diode $V_F \doteq 1.1$ V)

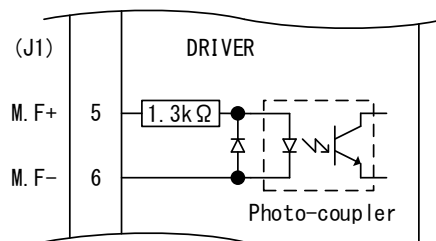

- Motor output current is shut off with the photo-coupler ON.
At this time, motor torque changes to detent torque.
- When this signal is input, motor torque may be lost, resulting in failure to retain the load transported.
In particular, this risk is high with the vertical drive (such as the Z-axis).

② Timing chart

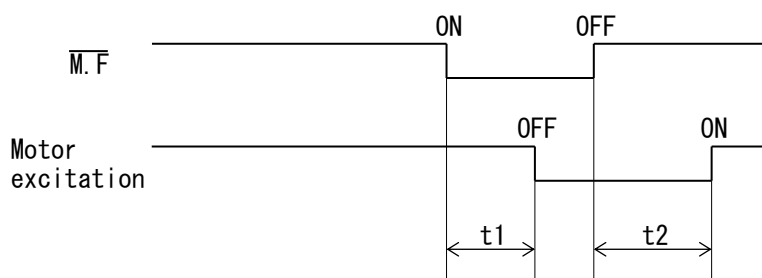

$t_1 \leq 5\text{ms}$ (t_1 : Time required for the motor output current to be shut off.)
 $t_2 \leq 100\text{ms}$ (t_2 : Time required for the motor to be enabled.)

(4) Phase signal output (P.0)

- ① Output current
- a. $I_C \leq 6\text{mA}$, $V_{CE} < 2\text{V}$
 - b. $I_C \leq 2\text{mA}$, $V_{CE(sat)} < 0.6\text{V}$
 $V_{CE0} \leq 30\text{V}$

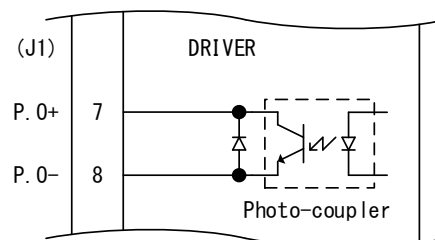

- In case of the excitation home position, the signal is output.
(photo-coupler ON)

② Timing chart

- P.0 output timing (for 1/1 STEP)

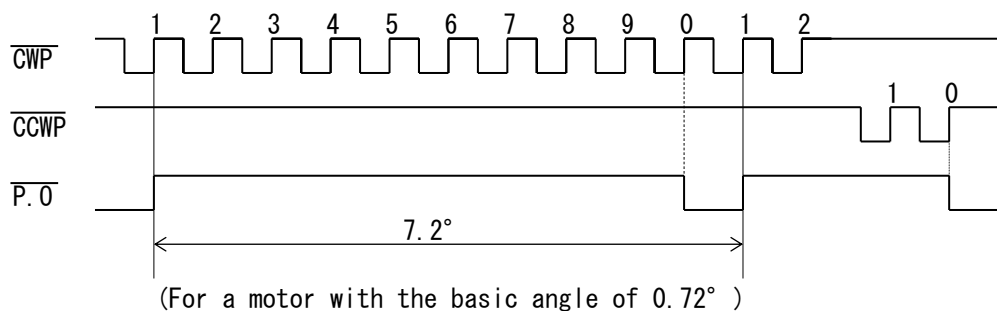

- P.0 output time

- 1/1 STEP: once in 10 pulses
- 1/2 STEP: once in 20 pulses
- 1/4 STEP: once in 40 pulses
- 1/10 STEP: once in 100 pulses
- 1/20 STEP: once in 200 pulses
- 1/40 STEP: once in 400 pulses

1 0 – 3. Overheat alarm LED (O. H. A)

 **WARNING**

Overheating may cause fire.
Stop operation when this LED comes on.

- In case of internal temperature of the driver reaches approx. 70°C or more, O. H. A LED comes on.
At this time the motor output current is not blocked.
- When O. H. A LED comes on, stop operation and check if there is any abnormality occurring with the motor and the driver.
- Provide mechanical cooling, for example, if O. H. A LED comes on while no abnormality is detected.
- Continuous operation is possible unless O. H. A LED comes on.

1 0 - 4. Dimensions

(Unit : mm)

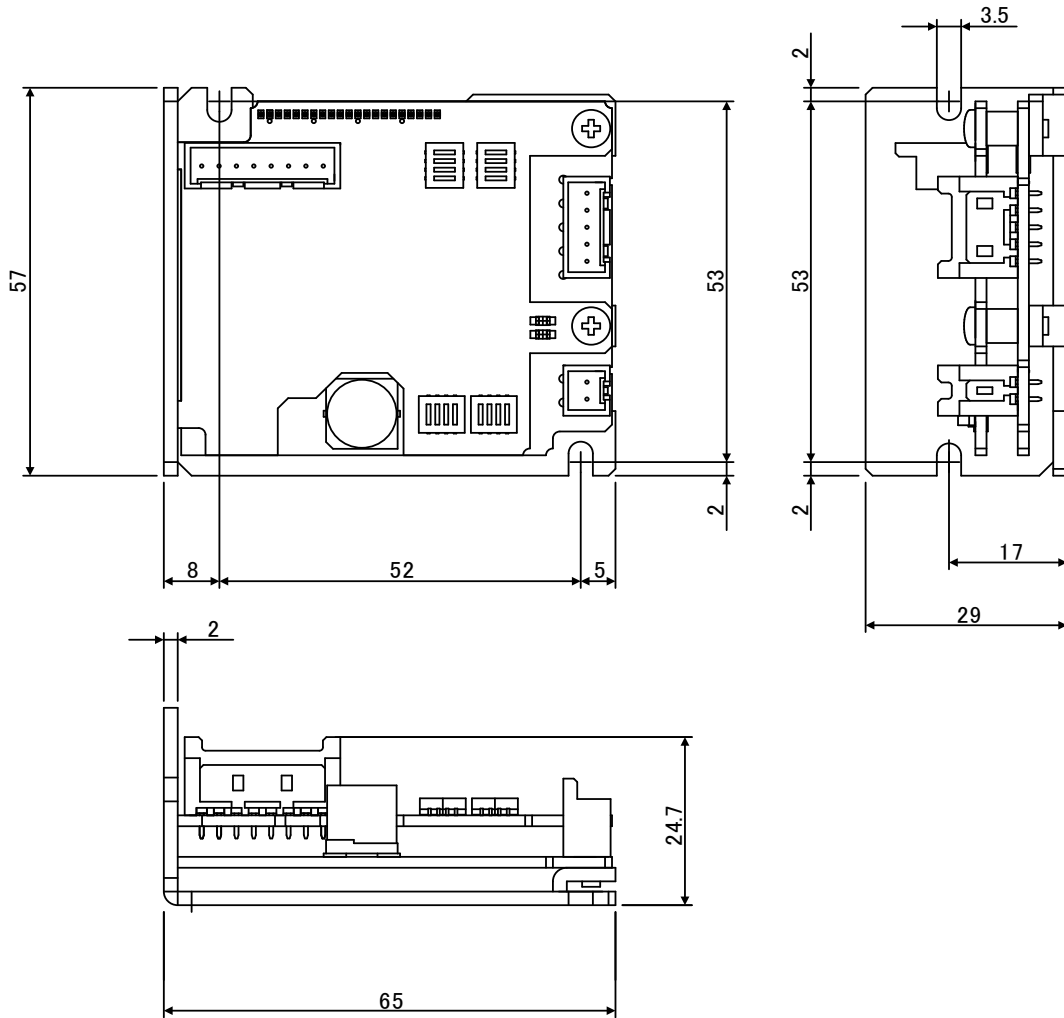

1 0 – 5. Applicable Motors

(1) ADB-5K30 can drive a 5-phase stepping motor with 0.35A/phase and 0.75A/phase.

① Examples of applicable motors

SANYO DENKI Co., LTD.		Basic Angle (°)	Current (A/phase)	Setting DRIVE I. SEL switch No.	Torque Data Fig. No.
□28mm	SH5281-3241	0.72	0.35	OFF	Fig. 1
	SH5281-7241 (7211)	0.72	0.75	ON	Fig. 2
	(SH5281-7411)	0.72	0.75	ON	Fig. 3
	SH5285-7241 (7211)	0.72	0.75	ON	Fig. 4
	(SH5285-7411)	0.72	0.75	ON	Fig. 5
□42mm	103F5505-7241 (7211)	0.72	0.75	ON	Fig. 6
	103F5508-7241 (7211)	0.72	0.75	ON	Fig. 7
	103F5510-7241 (7211)	0.72	0.75	ON	Fig. 8
ORIENTAL MOTOR Co., Ltd.		Basic Angle (°)	Current (A/phase)	Setting DRIVE I. SEL switch No.	Torque Data Fig. No.
□42mm	PK543-A (B)	0.72	0.75	ON	Fig. 9
	PK544-A (B)	0.72	0.75	ON	Fig. 10
	PK545-A (B)	0.72	0.75	ON	Fig. 11
□60mm	PK564-A (B)	0.72	0.75	ON	Fig. 12
	PK566-A (B)	0.72	0.75	ON	Fig. 13
TAMAGAWA SEIKI CO., LTD.		Basic Angle (°)	Current (A/phase)	Setting DRIVE I. SEL switch No.	Torque Data Fig. No.
□20mm	TS3682N1 (N11)	0.72	0.35	OFF	Fig. 14
	TS3682N2 (N12)	0.72	0.35	OFF	Fig. 15
□24mm	TS3664N1E2 (N11E2)	0.72	0.75	ON	Fig. 16
	TS3664N2E4 (N12E4)	0.72	0.75	ON	Fig. 17
Factory Setting				ON	—

() : Both axes

● Please contact us if you want to use the motor other than the above to our office.

1 0 – 6. Torque Characteristics

- (1) Representations in the torque characteristics table are made in terms of the motor rotation (s^{-1}) vs. torque ($N \cdot m$).

Motor rotation (s^{-1}) and drive pulse frequency (Hz) are converted as follows:

$$\text{Motor rotation}(s^{-1}) \times \frac{360^{\circ}}{\text{Step angle}} = \text{Drive pulse input frequency(Hz)}$$

Motor rotation (s^{-1}) and motor rotation (r/min) are converted as follows:

$$\text{Motor rotation}(s^{-1}) \times 60 = \text{Motor rotation}(r/min)$$

● Use the Motor rotation at $100s^{-1}$ (6000r/min) or less.

- (2) The Maximum Starting Pulse Rate is represented as "fs" by the value at zero inertial load.
- (3) Upon operation, provide adequate allowance for torque.
- (4) The stepping motor may attain high temperature, depending on the operational conditions.
Use the stepping motor according to the Instructions Manual produced by motormakers.

Instructions Manual

Fig. 1

ADB-5K30
SH5281-3241
0.35A/PHASE

DRIVE I. SEL = OFF
DC24V

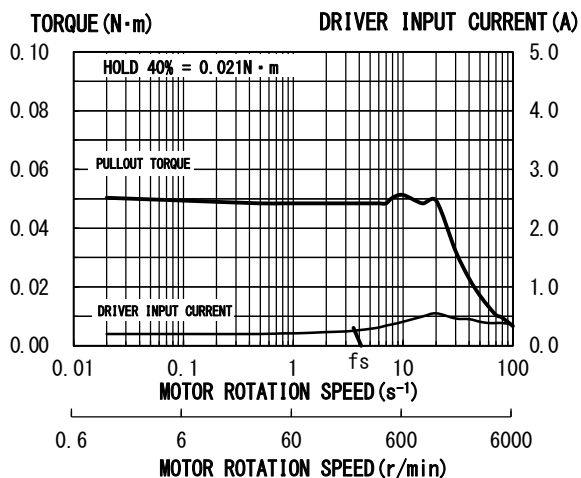

Fig. 2

ADB-5K30
SH5281-7241 (7211)
0.75A/PHASE

DRIVE I. SEL = ON
DC24V

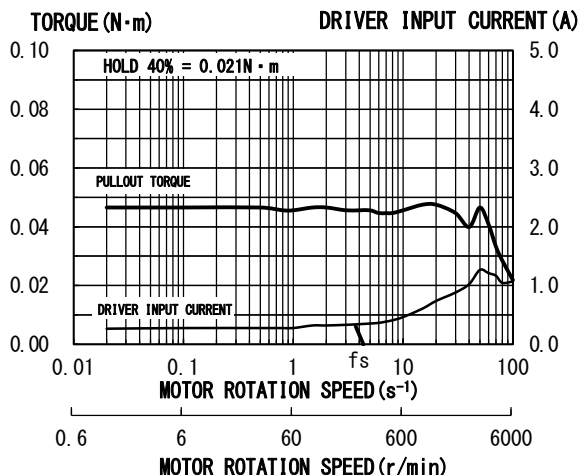

Fig. 3

ADB-5K30
SH5281-7411
0.75A/PHASE

DRIVE I. SEL = ON
DC24V

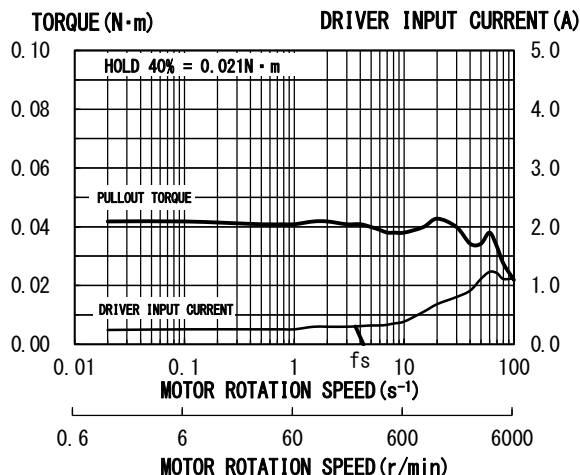

Fig. 4

ADB-5K30
SH5285-7241 (7211)
0.75A/PHASE

DRIVE I. SEL = ON
DC24V

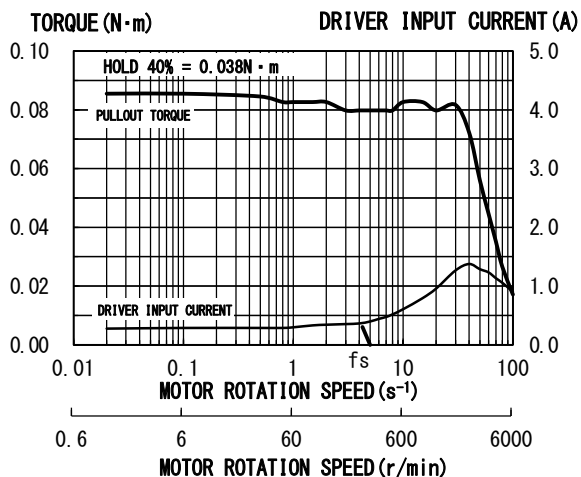

Fig. 5

ADB-5K30
SH5285-7411
0.75A/PHASE

DRIVE I. SEL = ON
DC24V

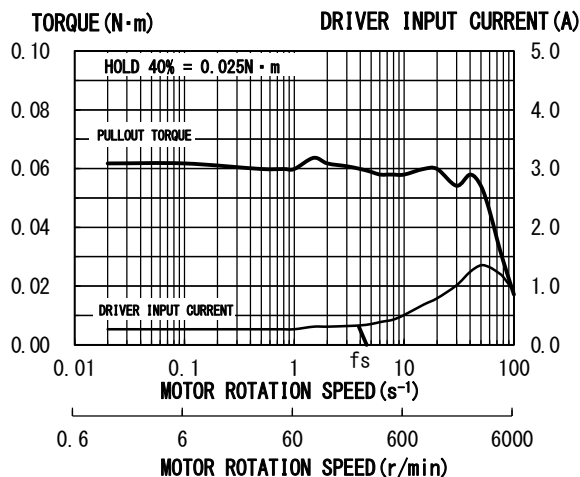

Fig. 6

ADB-5K30
 103F5505-7241 (7211)
 0.75A/PHASE

DRIVE I.SEL = ON
 DC24V

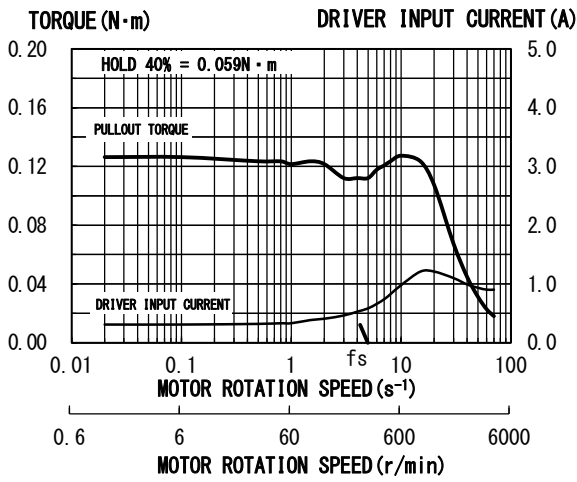

Fig. 7

ADB-5K30
 103F5508-7241 (7211)
 0.75A/PHASE

DRIVE I.SEL = ON
 DC24V

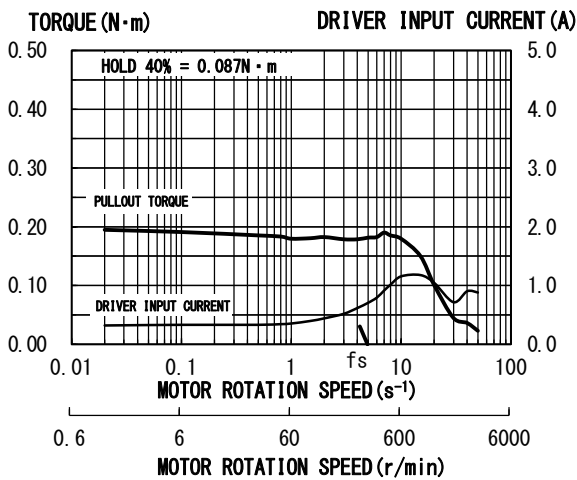

Fig. 8

ADB-5K30
 103F5510-7241 (7211)
 0.75A/PHASE

DRIVE I.SEL = ON
 DC24V

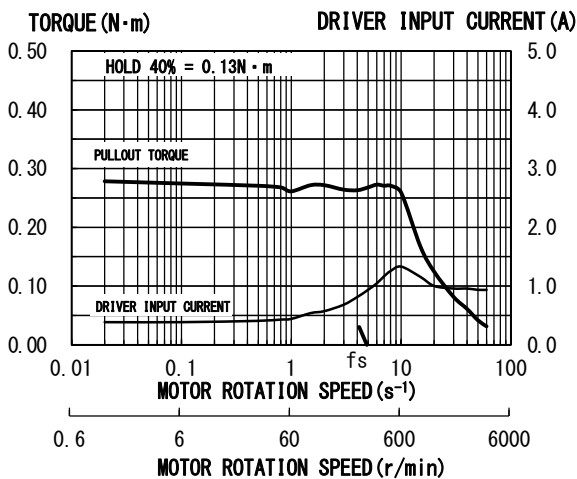

Fig. 9

ADB-5K30
 PK543-A (B)
 0.75A/PHASE

DRIVE I.SEL = ON
 DC24V

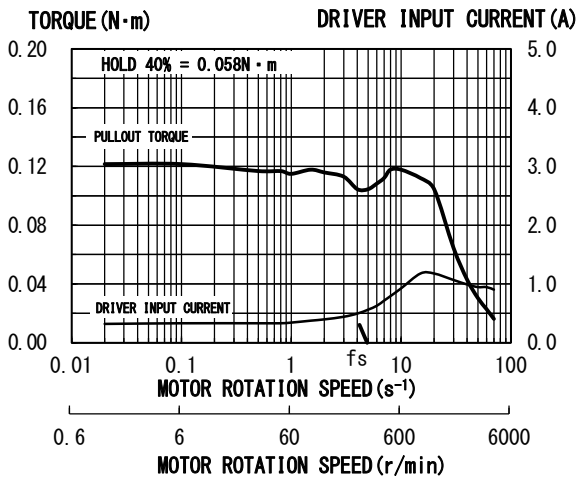

Fig. 10

ADB-5K30
 PK544-A (B)
 0.75A/PHASE

DRIVE I.SEL = ON
 DC24V

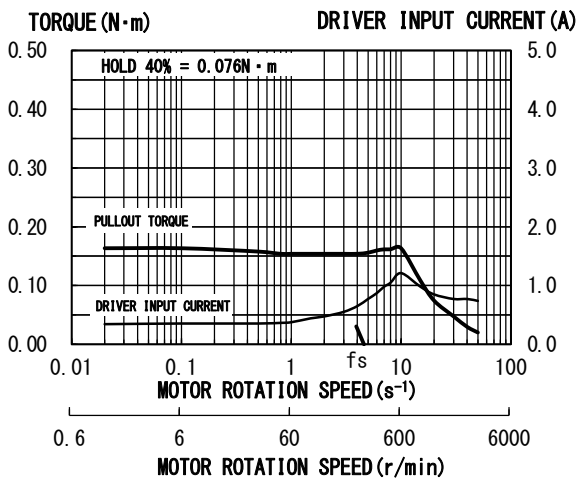

Fig. 11

ADB-5K30
 PK545-A (B)
 0.75A/PHASE

DRIVE I.SEL = ON
 DC24V

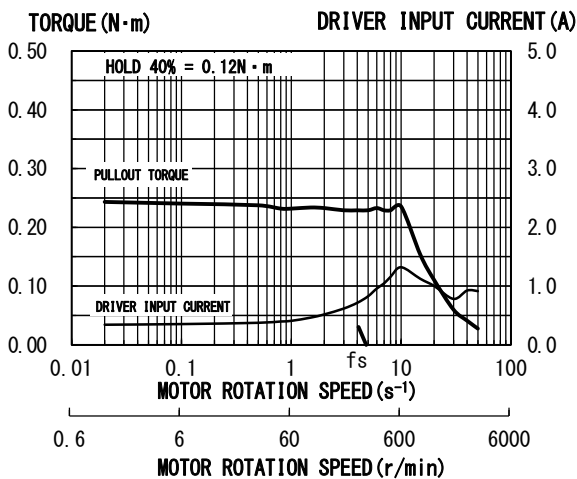

Fig. 12

ADB-5K30
 PK564-A(B)
 0.75A/PHASE

DRIVE I.SEL = ON
 DC24V

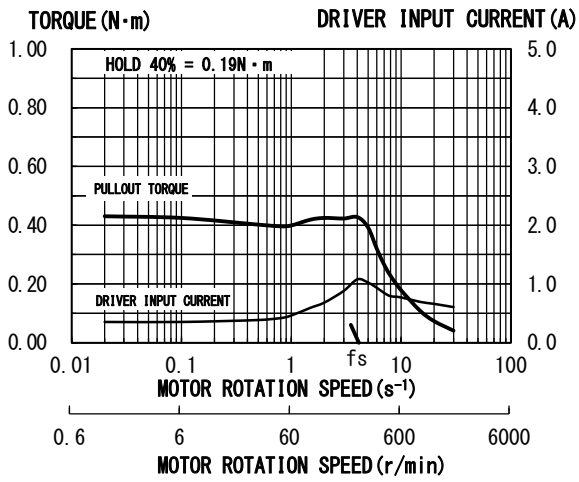

Fig. 13

ADB-5K30
 PK566-A(B)
 0.75A/PHASE

DRIVE I.SEL = ON
 DC24V

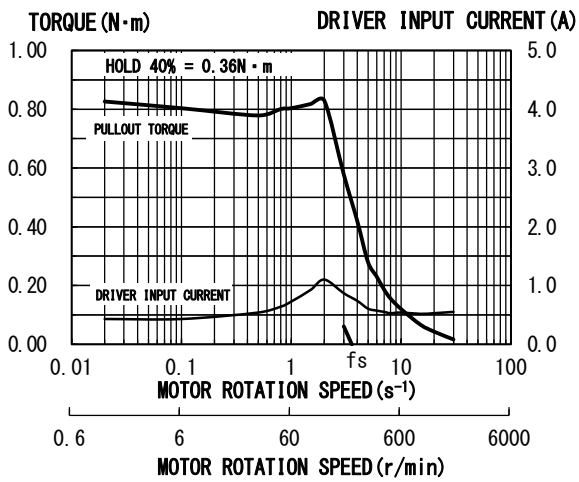

Fig. 14

ADB-5K30
 TS3682N1 (N11)
 0.35A/PHASE

DRIVE I.SEL = OFF
 DC24V

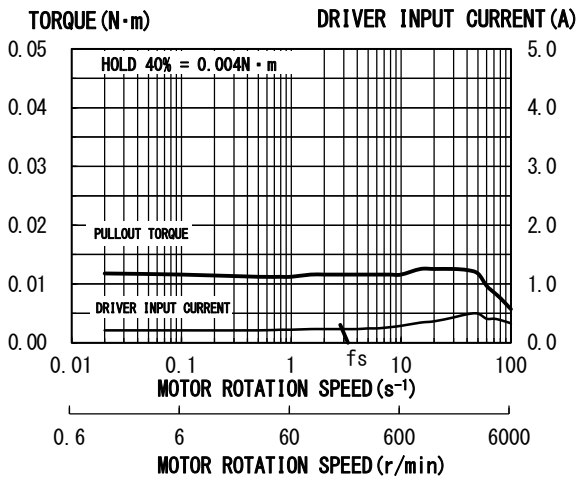

Fig. 15

ADB-5K30
 TS3682N2 (N12)
 0.35A/PHASE

DRIVE I.SEL = OFF
 DC24V

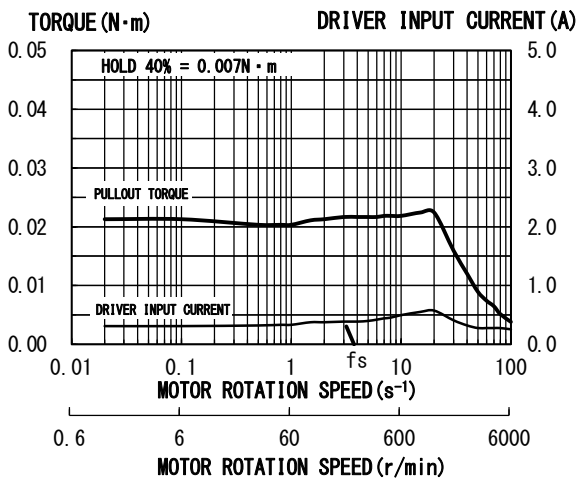

Fig. 16

ADB-5K30
 TS3664N1E2 (N11E2)
 0.75A/PHASE

DRIVE I.SEL = ON
 DC24V

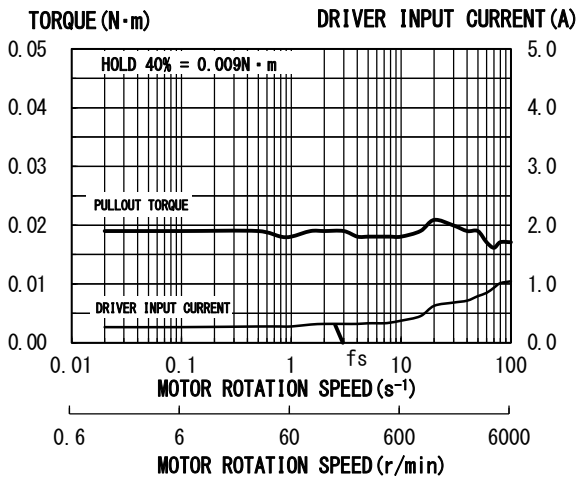
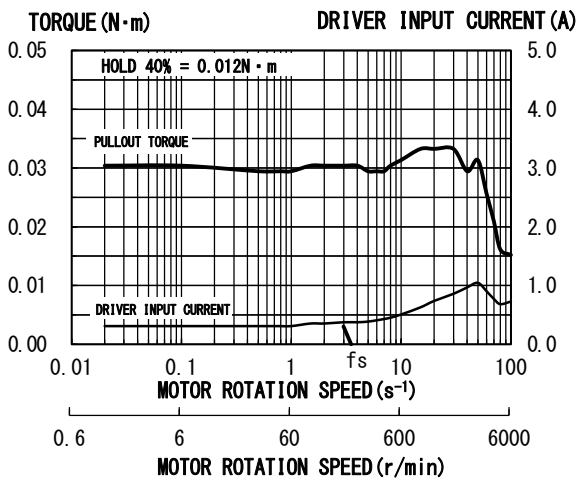

Fig. 17

ADB-5K30
 TS3664N2E4 (N12E4)
 0.75A/PHASE

DRIVE I.SEL = ON
 DC24V



10-7. Conforming to Europe standards

(1) Low voltage directive

This product is not subject to the EC's Low Voltage Directive by the following.

- This product should be installed within an enclosure.
- For the driver's power supply, use a DC power supply with reinforced insulation on its primary and secondary sides.

(2) EMC directive

This product declares the CE marking based on the EMC Directive by oneself.

● Applicable Standards

EN61000-6-4

EN61000-6-2

● This product conducted EMC measurement with the system configuration for EMC.

- EMC characteristic may vary depending on the configuration of the equipment that contains the driver or stepping motor. Be sure to conduct EMC measurement with the product assembled in your equipment.

Configuration

The metallic enclosure and shielded wires and ferrite core work to shield noise.

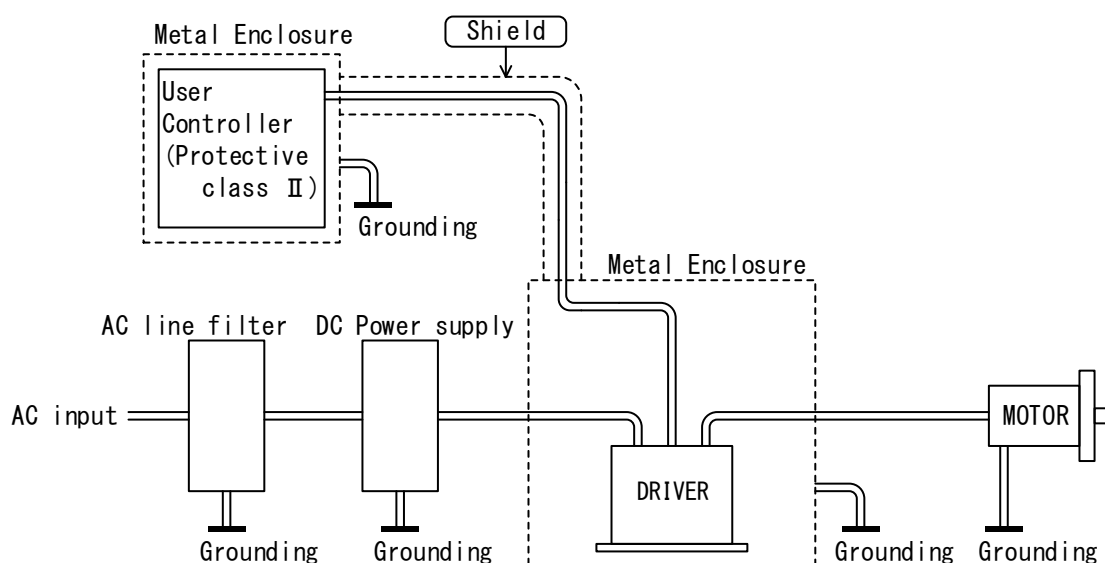

(3) RoHS directive

This product does not contain the substances exceeding the restriction values.

The main parts which revised by this manual

Parts	Content

**Technical Service
Sales and Service**

TEL. (042) 664-5384 FAX. (042) 666-2031
E-mail s-support@melec-inc.com

Melec Inc.

516-10, Higashiasakawa-cho, Hachioji-shi, Tokyo 193-0834, Japan
www.melec-inc.com

This Operating Manual is subject to change without prior notice
for the purpose of product improvement.

C2309