

Melec

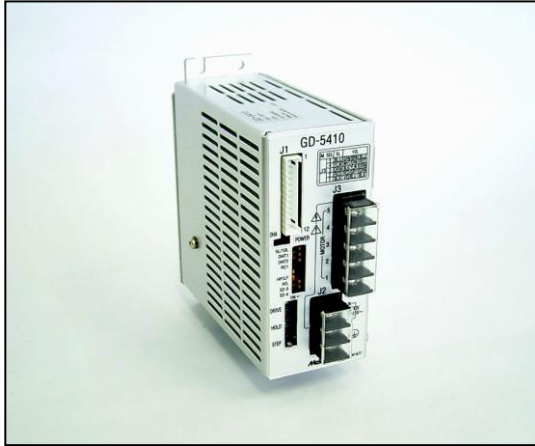

5-phase Stepping Motor Driver

GD-5410

Instructions Manual (For designers' use)

USER'S MANUAL

Please ensure to read and understand this Instructions Manual before using the product. Please keep this Instructions Manual at hand so that it is always available for reference.



MN0028-4

Introduction

This Instructions Manual describes the safe and proper method of handling "5-phase Stepping Motor Driver GD-5410" with emphasis on the specifications, assuming that our readers are engaged in designing of control devices incorporating stepping motors.

Please ensure to read and understand this Instructions Manual before using the product.

Please keep this Instructions Manual at hand so that it is always available for reference.

Descriptions in this manual on safety matters:

This product must be operated and used properly.

Otherwise, or when it is operated and used erroneously, unforeseen accidents may occur, causing physical injuries or property damages.

Majority of these accidents can be avoided if you are well informed of hazardous circumstances in advance.

Consequently, this instructions manual describes all the hazardous and dangerous circumstances and situations which can be foreseen and anticipated as well as necessary precautions.

All the above descriptions are being titled by the following symbol-marks and signal-words, namely:



Represents warnings ignorance of which can cause accidents involving fatal or serious physical injuries, or death.



Represents cautions ignorance of which can cause accidents involving minor physical injuries or property damages.

Introduction

Descriptions in this manual on safety matters:

	CONTENTS	PAGE
1. Safety		
1-1. Safety Precautions		6
1-2. Safety Information for Handling		7
2. Overview		
2-1. Characteristics		11
2-2. Product Configuration		11
2-3. Appearance		11
3. Name and Function of Each Section		
3-1. Signal I/O Connector (J1)		12
3-2. AC Input/Motor Output Terminal Block (J2, J3)		13
3-3. Operating Section		14
3-4. POWER LED		14
3-5. O. H. A LED		14
4. Function Set-up by Use		
4-1. Setting MOTOR SELECT switch		15
4-2. Setting HIGH-SPEED POWER OUTPUT SELECT switch		15
4-3. Setting STEP ANGLE SELECT switch		16
4-4. Setting HOLD CURRENT SELECT switch		17
4-5. Setting DRIVE CURRENT SELECT switch		18
4-6. Setting HOLD SWITCHING TIME SELECT switch		19
4-7. Setting ROTATE CHARACTERISTIC SELECT switch		19
5. Installation		
5-1. Conditions for Installation		20
5-2. Mounting Method		21
6. Connection		
6-1. Overview of Connection Configuration		22
6-2. Connecting Signal I/O Connector (J1)		23
6-3. Connecting AC Input/Motor Output Terminal Block (J2, J3)		24
6-4. Inputting Power		26
7. Confirmation of Setting and Connection		
7-1. Check Points		27

8. Maintenance and Check-up	
8-1. Maintenance and Check-up	28
8-2. Troubleshooting	29
9. Storing and Disposal	
9-1. Storing	30
9-2. Disposal	30
10. Specifications	
10-1. General Specifications	31
10-2. Conforming to UL standards	32
10-3. I/O Signal	
(1) Example Circuit Connection	33
(2) Drive pulse input (CW, CCW)	34
(3) Motor excitation stop input (M. F)	35
(4) Phase signal output (P. O)	36
(5) Overheat alarm signal output (O. H. A)	37
(6) Step angle switch input (C. S)	38
10-4. Dimensions	39
10-5. Applicable Motors	40
10-6. Torque Characteristics	41

The main parts which revised by this manual

1. Safety

1 – 1. Safety Precautions

 **WARNING**

- (1) This product is not designed or manufactured for application for equipment requiring high level of reliability such as equipment related to nuclear energy, aeronautics-related equipment, automobiles, ships, medical appliances directly handling the human body and equipment that might seriously affect properties.
- (2) Do not use or keep the product in explosive or corrosive environments, in the presence of flammable gases, locations subjected to splashing water, fine particles, soot, steam, or exposed to radiation or direct sunshine. Doing so may cause electric shock, injury or fire.
- (3) Do not transport, move, install the product, perform connections or inspections when the power is on. Doing so may cause electric shock.
- (4) Only qualified personnel are allowed to transport, move, install the product, perform connections or inspections. Failure to do so may cause electric shock, injury or fire.
- (5) This product is for a devices inclusion. Please establish it into enclosure without fail. Be sure to ground the protective earth terminal of the driver.

 **CAUTION**

- (6) Do not touch the driver during operation or immediately after stopping. Doing so may cause burn on the skin due to overheating of the driver.
- (7) Ensure to use this product according to the method specified in the Instructions Manual and within the specifications.
- (8) Depending on the operational conditions, the stepping motor may step out when it is on holding-state or driving-state. In particular, the load in transport may fall if the motor steps out on the vertical drive (such as the Z-axis). Start operation after test run for deliberate confirmation of operation.
- (9) Provide fail-safe measures so that the entire system may operate in a safe mode even in cases of the external power supply failure, disconnection of the signal line, or any failure on the driver.

1 – 2. Safety Information for Handling

●Overall:

 **WARNING**

Use only an insulated screwdriver to adjust or set internal switches.
Failure to do so may cause electric shock.

 **CAUTION**

Do not touch the driver during operation or immediately after stopping.
Doing so may cause burn on the skin due to overheating of the driver.

●When connecting the AC Input/Motor Output Terminal Block (J2, J3):

 **WARNING**

Turn the main power OFF.
Failure to do so may cause electric shock.

 **WARNING**

Securely ground the protective earth terminal .
Failure to do so may cause electric shock.

 **WARNING**

Do not force the power line or the motor line to be bent or pulled or pinched.
Doing so may cause electric shock or fire.

 **CAUTION**

Erroneous connection may result in breakage of the motor or the driver.
Correctly connect the motor wiring.

- When setting up the MOTOR SELECT switch:

 CAUTION

Erroneous setting may cause burn on the skin due to overheating of the motor.
Ensure correct setting.

- When setting up the STEP ANGLE SELECT switch:

 CAUTION

Erroneous setting may cause breakage of the machine or injury due to unexpected rotation of the motor.
Ensure correct setting.

- When setting up the HOLD CURRENT SELECT switch:

 CAUTION

A high setting value may cause burn on the skin due to overheating of the motor.
Do not select a high value beyond the required.

- When setting up the DRIVE CURRENT SELECT switch:

 CAUTION

Erroneous setting may cause burn on the skin due to overheating of the motor.
Ensure correct setting.

- When inputting the motor excitation stop (M.F) signal:

 CAUTION

Deterioration of the holding power with the motor may cause breakage of machine or injury.
Check safety before inputting.

●When installing:

 **WARNING**



Mount it on a noncombustible member.
Keep it away from combustibles.
Overheating may cause fire.

●When inputting power:

 **WARNING**

Do not contact with a wet hand.
Doing so may cause electric shock.

 **WARNING**

The marks,  and , on the front panel indicate terminals on which power voltage is applied.
Do not touch such terminals while inputting power and while POWER LED is on.
Doing so may cause electric shock.

 **CAUTION**

Unexpected behavior of the motor may cause breakage of the machine or injury.
Maintain the state where emergency stop is enabled at any time.

●When the overheat alarm (O. H. A) signal is output:

 **WARNING**

Overheating may cause fire.
Stop operation upon output of this signal.

●When performing maintenance and checking:



⚠WARNING

Only qualified personnel are allowed to perform maintenance and checking. Failure to do so may cause electric shock.

⚠WARNING

Do not contact with a wet hand. Doing so may cause electric shock.

⚠WARNING

The marks,  and , on the front panel indicate terminals on which power voltage is applied. Do not touch such terminals while inputting power and while POWER LED is on. Doing so may cause electric shock.

⚠WARNING

Do not replace fuse.
Do not disassemble, repair or modify.
Doing so may cause electric shock, injury or fire.

2. Overview

2-1. Characteristics

GD-5410 is a driver for a 5-phase stepping motor with single-phase 100-115V input. It can drive a 5-phase stepping motor ranging from 0.75A/phase ~ 1.4A/phase. Ten step angles can be selected from angles ranging from a 1/1 division to a 1/800 division of the basic angle. HOLD CURRENT and DRIVE CURRENT can be set up. HIGH-SPEED TORQUE can be selected for the motor.

- Applicable motors and setting for each motor are given in the table "10-5. Applicable Motors".

2-2. Product Configuration

The product consists of the main frame and the accessories.

- GD-5410 One unit
(Complete with terminal block covers)
- Housing for J1 (51103-1200:Molex) One unit (accessory)
- Contact for J1 (50351-8100:Molex) 14 contacts (accessories, 2 for spares)

2-3. Appearance

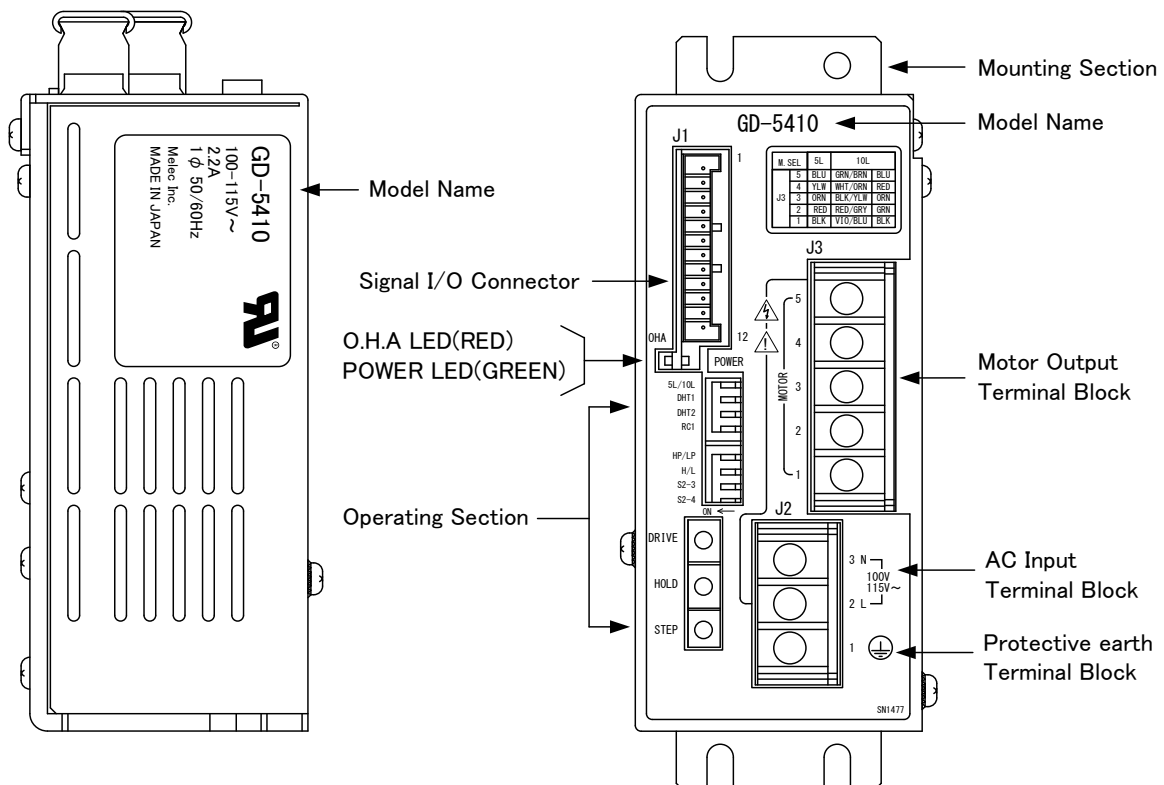

3. Name and Function of Each Section

3-1. Signal I/O Connector (J 1)

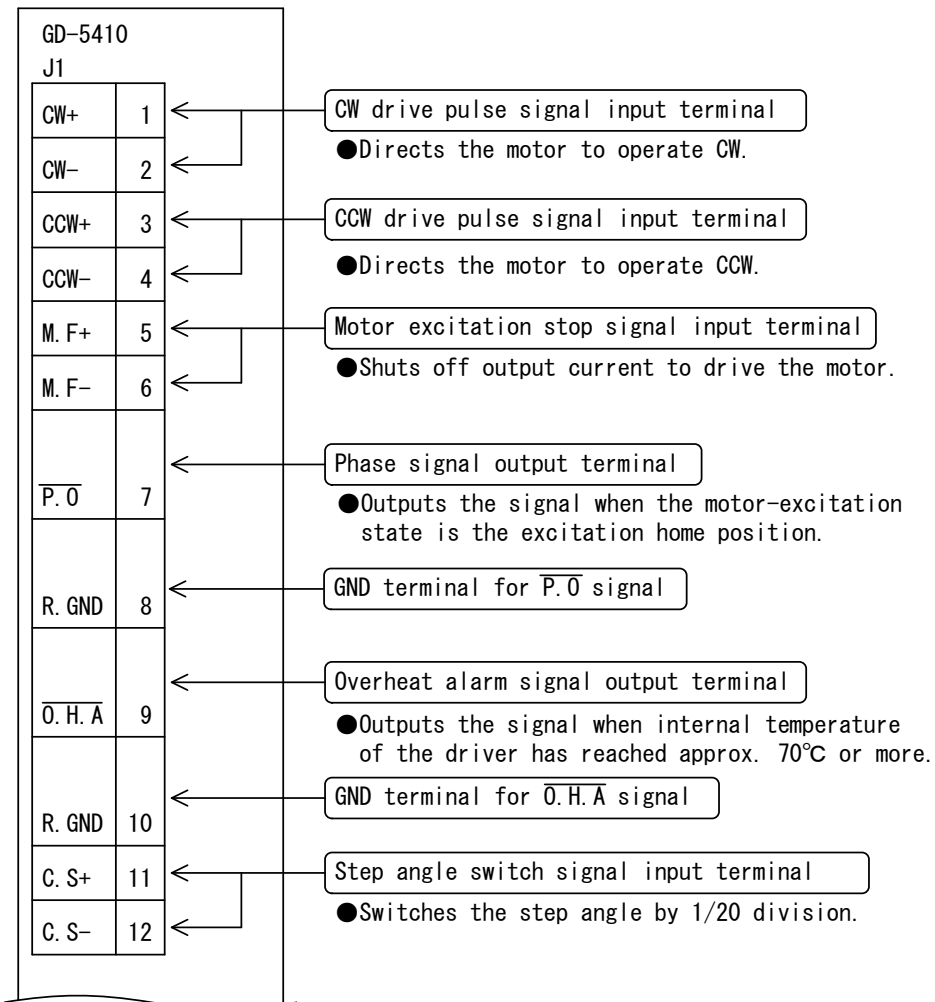

3 – 2. AC Input/Motor Output Terminal Block (J 2, J 3)

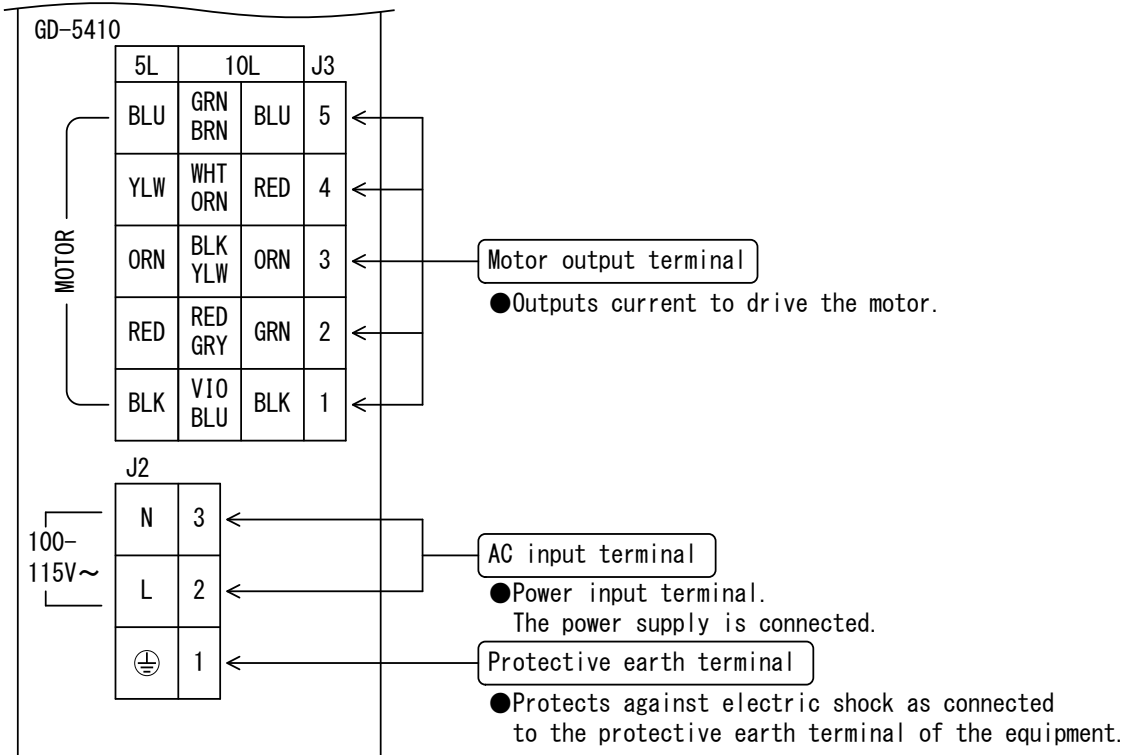

3 – 3. Operation Section

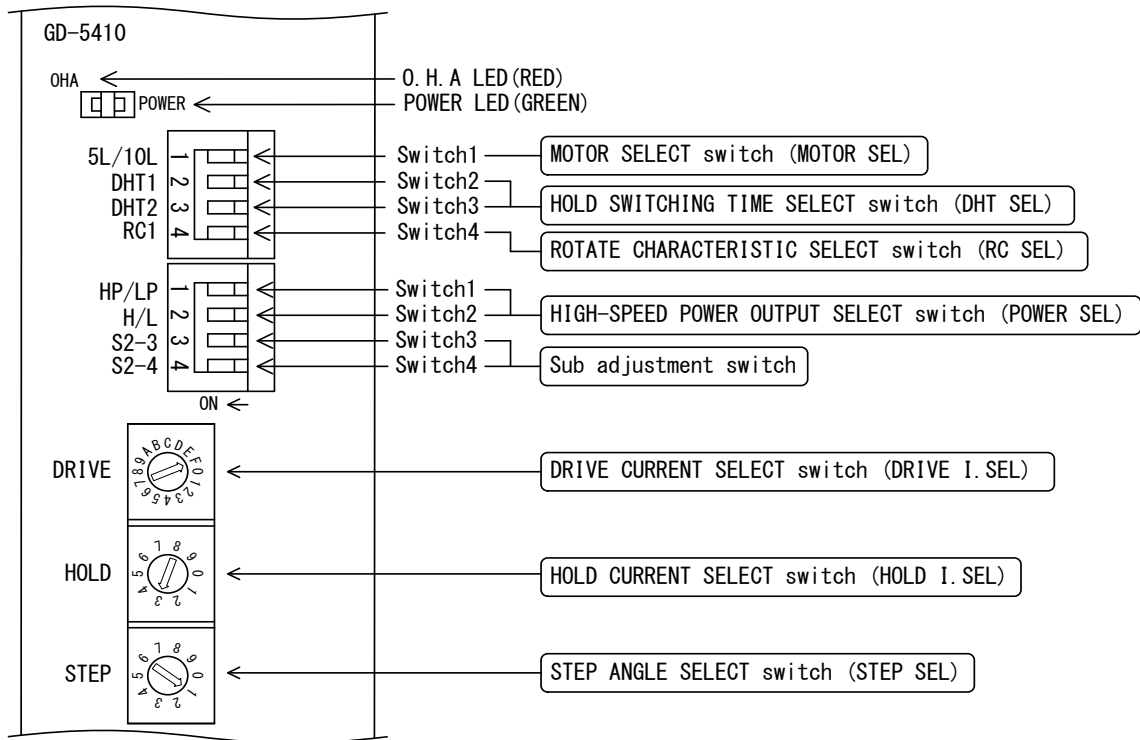

Name of Operation Section	Function	Factory Setting
MOTOR SELECT switch	Selects the applicable motor.	[10L]
HOLD SWITCHING TIME SELECT switch	DRIVE/HOLD CURRENT automatic switching time is selected.	[OFF, OFF]
ROTATE CHARACTERISTIC SELECT switch	Selects a characteristic of motor rotation.	[OFF]
HIGH-SPEED POWER OUTPUT SELECT switch	Selects HIGH-SPEED TORQUE for the motor.	[HP, H]
Sub adjustment switch	Please use it with OFF.	[OFF]
DRIVE CURRENT SELECT switch	Selects DRIVE CURRENT.	[No. F]
HOLD CURRENT SELECT switch	Selects HOLD CURRENT.	[No. 3]
STEP ANGLE SELECT switch	Selects a step angle.	[No. 1]

3 – 4. POWER LED

POWER LED (GREEN) comes on upon inputting power.

3 – 5. O. H. A LED

O. H. A LED (RED) comes on when internal temperature of the driver has reached approx. 70°C or more.

4. Function Set-up by Use

4 – 1. Setting MOTOR SELECT switch

⚠ CAUTION

Erroneous setting may cause burn on the skin due to overheating of the motor. Ensure correct setting.

The MOTOR SEL switch is turned to the setting corresponding to the motor in use. Set this switch with power OFF. The switch is factory-set to [10L].

- (1) Turn power [OFF].
- (2) Set the MOTOR SEL switch [10L/5L] to the setting specified in the table "10-5. Applicable Motors."

4 – 2. Setting HIGH-SPEED POWER OUTPUT SELECT switch

HIGH-SPEED TORQUE is set up with the POWER SEL switch. There are four different types of torque characteristics. The switch is factory-set to [HP, H].

- (1) Set the POWER SEL switch [HP/LP] [H/L] to the torque characteristic required.

- Relationships of the switch setting and heat generation by the motor and HIGH-SPEED TORQUE.

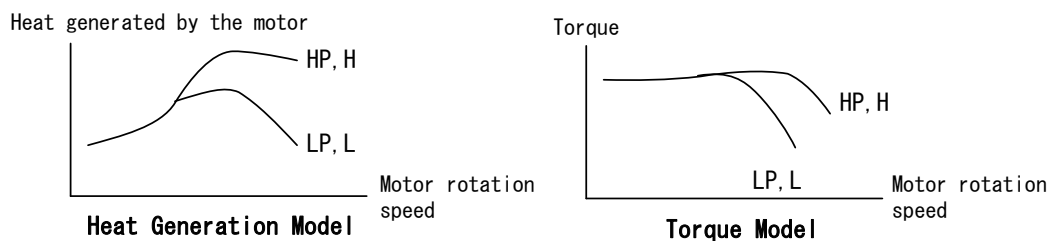

- Select the switch [HP, H] (ON, ON) if HIGH-SPEED TORQUE is required, and the switch [LP, L] (OFF, OFF) if not, in order to control heat generation by the motor.
- Selecting one of the switch setting types leads to power demand as shown below:

Switch setting	HP, H	HP, L	LP, H	LP, L
Power Demand (with DRIVE I. SEL No.F set up)	220VA	180VA	150VA	120VA

(Factory setting)

4 – 3. Setting STEP ANGLE SELECT switch

⚠ CAUTION

Erroneous setting may cause breakage of the machine or injury due to unexpected rotation of motor.
Ensure correct setting.

The step angle is set up with the STEP SEL switch.
The step angle can be selected from ten different types of step angles.
The switch is factory-set to [No.1].

(1) Set the STEP SEL switch No. to the step angle required.

● Relationship between the STEP SEL switch No. and the step angle.

Switch No.	Number of Divisions	Step angle(°)
		0.72° motor
0	1/1	0.72
1	1/2	0.36
2	1/4	0.18
3	1/10	0.072
4	1/20	0.036
5	1/40	0.018
6	1/100	0.0072
7	1/200	0.0036
8	1/400	0.0018
9	1/800	0.0009

(Factory setting)

● Driving with two types of step angles are provided by combining the STEP SEL switch setting and the C.S signal.

4 – 4. Setting HOLD CURRENT SELECT switch

 CAUTION

A high setting value may cause burn on the skin due to overheating of the motor. Do not select a high value beyond the required.

HOLD CURRENT is set up with the HOLD I.SEL switch. This sets the ratio of HOLD CURRENT to DRIVE CURRENT. The switch is factory-set to [No.3] :40%.

- (1) Set the HOLD I.SEL switch No. to the ratio of HOLD CURRENT to DRIVE CURRENT required.

● Ratio of HOLD CURRENT

$$\text{Ratio of HOLD CURRENT (\%)} = \frac{\text{HOLD CURRENT}}{\text{DRIVE CURRENT}} \times 100$$

Switch No.	Ratio of HOLD CURRENT (%)
0	10
1	20
2	30
3	40
4	50
5	60
6	70
7	80
8	90
9	100

(Factory setting)

- HOLD CURRENT changes relative to DRIVE CURRENT setting. The ratio of HOLD CURRENT set the switch No. to [No.9]:100% represents the same as the setting for DRIVE CURRENT.
- The greater the ratio of HOLD CURRENT grows, the more heat the motor generates when is on holding-state.

4 – 5. Setting DRIVE CURRENT SELECT switch

⚠ CAUTION

Erroneous setting may cause burn on the skin due to overheating of the motor. Ensure correct setting.

DRIVE CURRENT is set up with the DRIVE I.SEL switch. The switch is factory-set to [No.F].

- (1) Set the DRIVE I.SEL switch No. to the setting specified in the table "10-5. Applicable Motors".

● Relationship between the DRIVE I.SEL switch and DRIVE CURRENT.

MOTOR SEL switch	
switch1 : ON	
[5L]setting	
switch No.	A/phase
0	0.17
1	0.20
2	0.24
3	0.27
4	0.31
5	0.34
6	0.37
7	0.41
8	0.44
9	0.48
A	0.51
B	0.54
C	0.58
D	0.61
E	0.64
F	0.68

(Factory setting)

MOTOR SEL switch	
switch1 : OFF	
[10L]setting	
switch No.	A/phase
0	0.34
1	0.40
2	0.47
3	0.54
4	0.61
5	0.67
6	0.74
7	0.81
8	0.88
9	0.95
A	1.01
B	1.08
C	1.15
D	1.21
E	1.28
F	1.35

(Factory setting)

4 – 6. Setting HOLD SWITCHING TIME SELECT switch

DRIVE/HOLD CURRENT automatic switching time is set up with the DHT SEL switch.

The switch is factory-set to [DHT2:OFF] [DHT1:OFF] (150ms).

- (1) Set the DHT SEL switch [DHT2] [DHT1] to the DRIVE/HOLD CURRENT automatic switching time required.

DHT2	OFF	OFF	ON	ON
DHT1	OFF	ON	OFF	ON
HOLD SWITCHING TIME	150ms	16ms	8ms	4ms

4 – 7. Setting ROTATE CHARACTERISTIC SELECT switch

The switch is factory-set to [RC1:OFF].

- By setting the RC SEL switch to [RC1:ON] the vibration of the motor in acceleration or deceleration may reduce.
- Select it after evaluated characteristic with an actual device.

5 – 2. Mounting Method

The following items are required:

- M-4 screw (8mm or more in length) :----- 4
- M-4 spring washer: ----- 4
- M-4 flat washer: ----- 4

- (1) Temporarily fix the product at the round hole.
- (2) Fix the product at the three cutouts.
- (3) Fasten the screw in the round hole.

● Mounting example

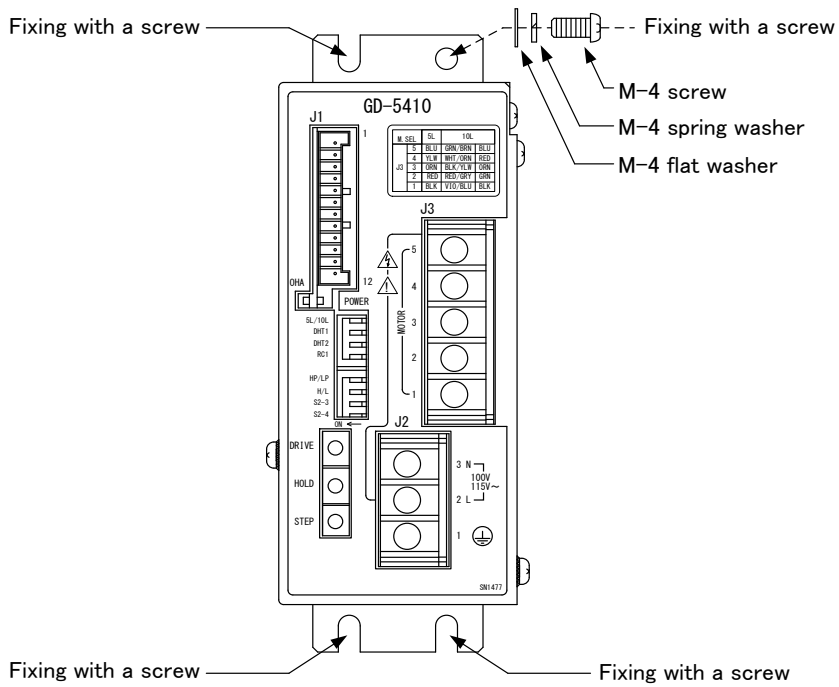

6. Connection

6-1. Overview of Connection Configuration

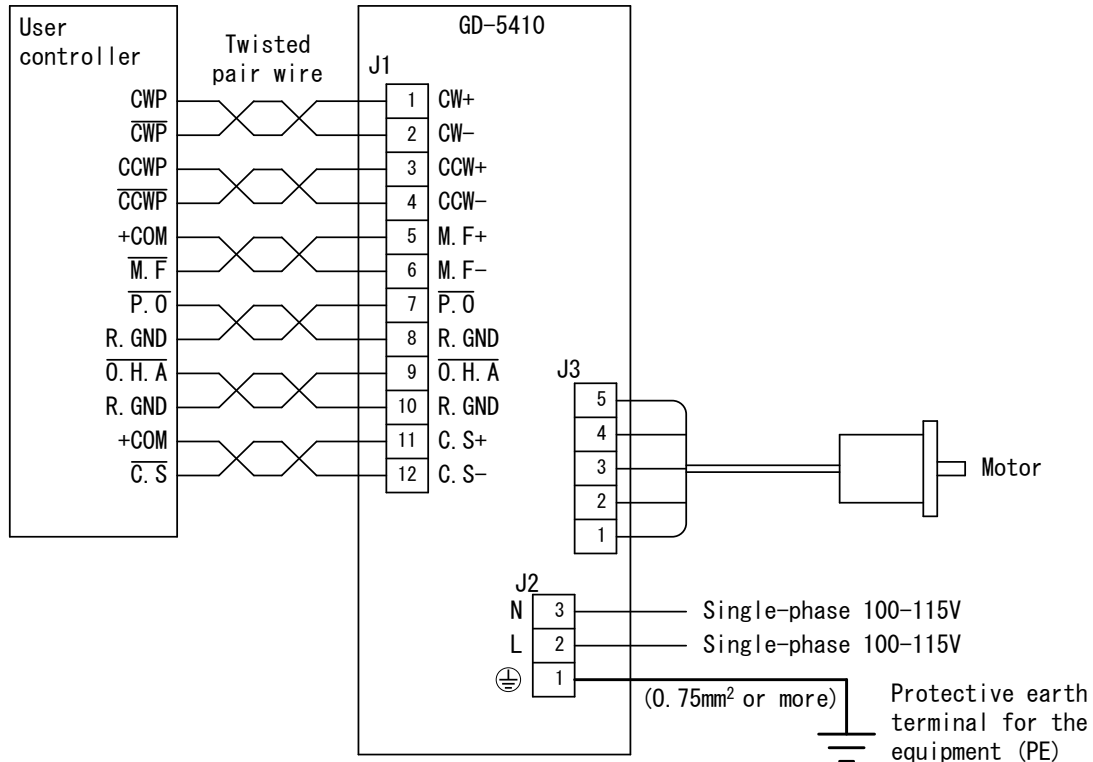

- Connect only one motor to one driver.
- Use twisted pair wire for the CW/CCW input signal line.
- Provide shielding for the signal line where considerable noise is generated.
- Use the wire material of the characteristic that is difficult to burn.
- Provide shielding for the motor line if it generates significant noise.

[Example configuration]

The metallic enclosure and shielded wires work to shield noise.

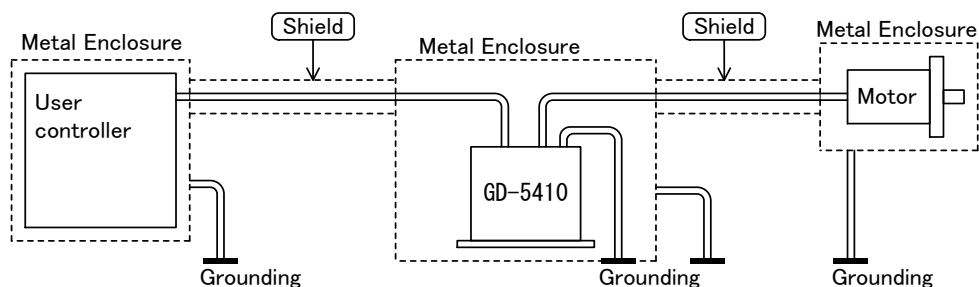

6-2. Connecting Signal I/O Connector (J1)

The following items are required:

- Housing for J1 (51103-1200:Molex): --- One unit (accessory)
- Contact for J1 (50351-8100:Molex): --- 12 contacts (accessories)
- Manually operated crimping tool
for AWG28-22(57295-5000:Molex): ----- One unit

- (1) Crimp the contact to the cable used for wiring.
- (2) Insert the contact into the housing.
Make sure that the housing No. and the connector No. on the main frame are matched before inserting the contacts.
- (3) Connect the housing to the connector on the main frame.
 - The contacts for J1 are 12 pieces.
 - When inserting, keep pushing J1 housing into the connector until it is locked. Also, check if the contacts are not displaced from the housing.
 - In wiring, isolate the J1 signal lines from equipment that may be a source of noise, the power line and the motor line.

(Surface on which the contacts are inserted)

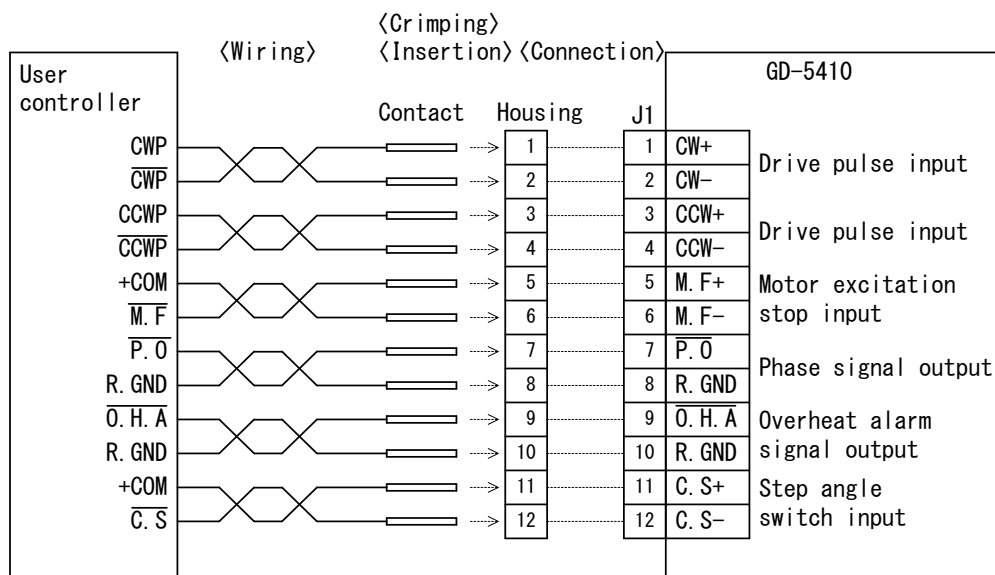
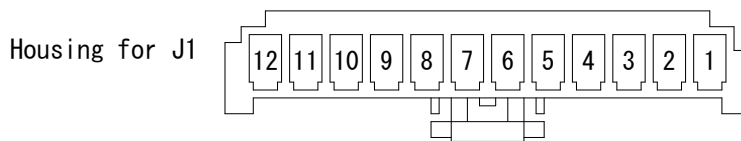

- Use a signal cable of AWG26(0.15mm²) or more in diameter.

6 – 3. Connecting AC Input/Motor Output Terminal Block (J 2, J 3)

⚠ WARNING

Turn the main power OFF.
Failure to do so may cause electric shock.

⚠ WARNING

Securely ground the protective earth terminal \oplus .
Failure to do so may cause electric shock.

⚠ WARNING

Do not force the power line or the motor line to be bent or pulled or pinched.
Doing so may cause electric shock or fire.

⚠ CAUTION

Erroneous connection may result in breakage of the motor or the driver.
Correctly connect the motor wiring.

The following items are required:

- Crimping terminal ----- 8
(TMEV1.25-3: Nichifu or the equivalent)
- Manually operated crimping tool for AWG22-16---- One unit
(NH-11: Nichifu or the equivalent)

- (1) Turn power of the equipment [OFF].
- (2) Crimp the crimping terminals to the cable used for wiring.
- (3) Remove the covers of terminal block, then connect.
- (4) Fix the terminal block covers after completing connection.

[Protective earth terminal • AC input terminal]

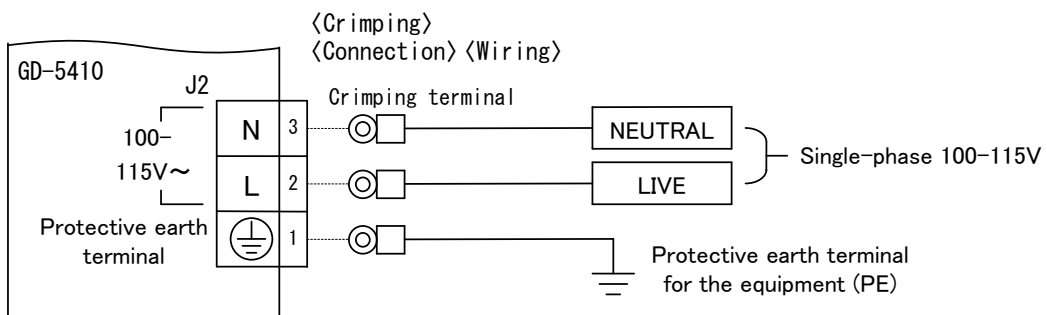

- Be sure to ground the protective earth terminal (⊕) of the driver to the protective earth terminal of the equipment (PE).
- Use a protective earth cable and power cable of AWG18(0.75mm²) or more in diameter.

[Motor output terminal]

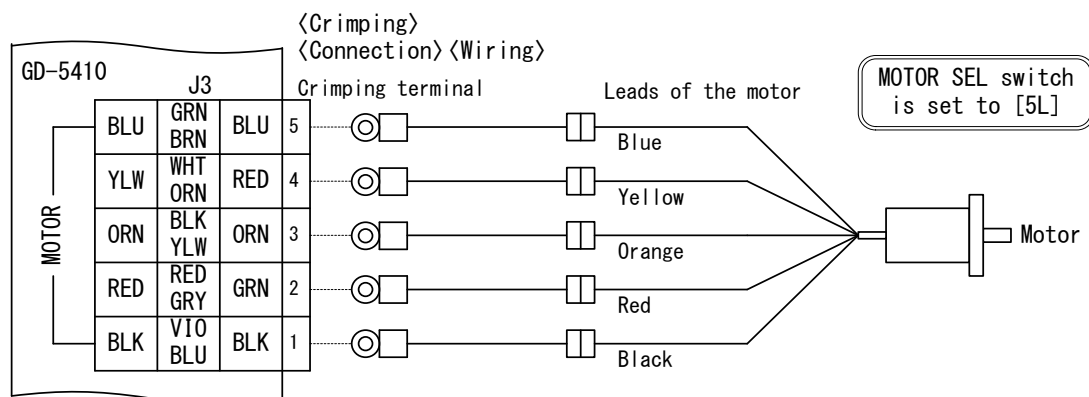
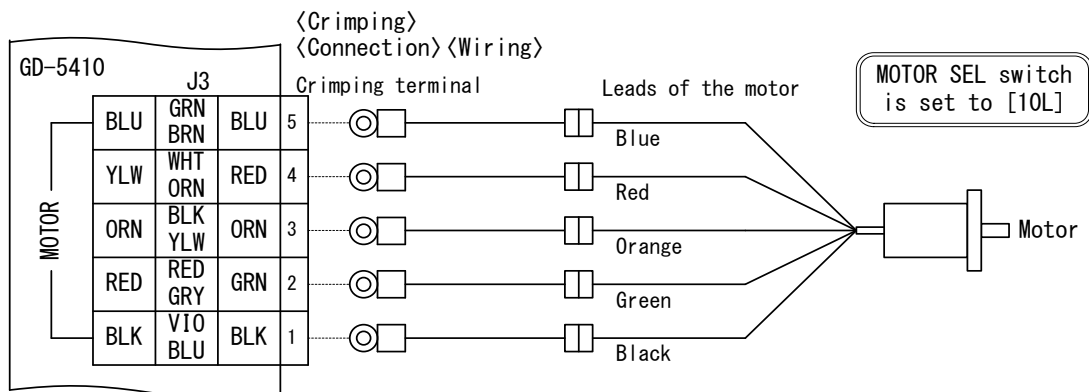
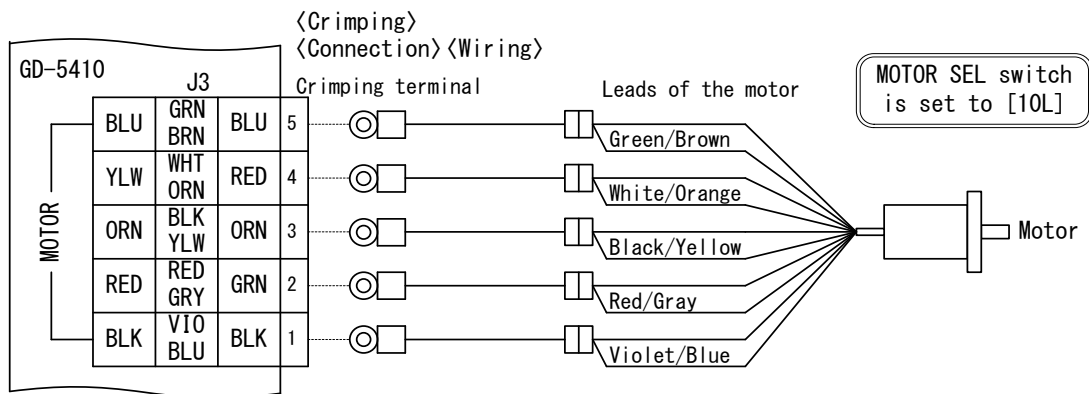



- Use a motor cable of AWG20(0.5mm²) or more diameter.
- Color indications for the motor crimping terminals (1~5) represent colors of the leads of the motor.

6 – 4. Inputting Power

 **WARNING**

Do not contact with a wet hand.
Doing so may cause electric shock.

 **WARNING**

The marks,  and , on the front panel indicate terminals on which power voltage is applied.
Do not touch such terminals while inputting power and while POWER LED is on.
Doing so may cause electric shock.

 **CAUTION**

Unexpected behavior of the motor may cause breakage of the machine or injury.
Maintain the state where emergency stop is enabled at any time.

- (1) Input power (single-phase 100–115V) into the cable connected to No. 2 and No. 3 terminals of J2.

7. Confirmation of Setting and Connection

7 – 1. Check Points

- (1) This product requires different switch setting and motor wiring depending on the motor used.
Check if the switch setting and the motor wiring are correctly performed.
- (2) Check if the protective earth terminal (⊕) of J2 is securely wired.
- (3) Check if the terminal block covers are fixed on J2 and J3.

Check Points		Check	Remarks
Setting of MOTOR SELECT switch	10L/5L		
Setting of HOLD SWITCHING TIME SELECT switch	DHT2, DHT1		
HIGH-SPEED POWER OUTPUT SELECT switch	L/H		
	LP/HP		
Setting of DRIVE CURRENT SELECT switch	Switch No.		
Setting of STEP ANGLE SELECT switch	Switch No.		
Setting of HOLD CURRENT SELECT switch	Switch No.		
Connection of J1			
Connection of J2	Protective earth terminal (⊕)		
	AC input terminal (L, N)		
	Terminal block cover		
Connection of J3	Motor output terminal		
	Terminal block cover		

8. Maintenance and Check-up

8 – 1. Maintenance and Check-up



⚠ WARNING

Only qualified personnel are allowed to perform maintenance and checking. Failure to do so may cause electric shock.

⚠ WARNING

Do not contact with a wet hand. Doing so may cause electric shock.

⚠ WARNING

The marks,  and , on the front panel indicate terminals on which power voltage is applied. Do not touch such terminals while inputting power and while POWER LED is on. Doing so may cause electric shock.

⚠ WARNING

Do not replace fuse. Do not disassemble, repair or modify. Doing so may cause electric shock, injury or fire.

- (1) As for a maintenance inspection the engineer of the specialty shall do it.
- (2) We recommend that the following check-ups should be performed periodically:
 - Checking for any loosened screws on the terminal block and contacts on the connectors.
 - Checking for any flaw and crack on the cabling.
- (3) In case of failure, return the driver to us and have it repaired.

8 – 2. Troubleshooting

Trouble	Check Item	Assumed Cause
1. POWER LED does not come on.	<ul style="list-style-type: none"> • Connection of power supply. • Value of power voltage. 	<ul style="list-style-type: none"> • Wiring error with power supply. • Power voltage failure. • Driver failure.
2. The motor is not excited. (It can be easily rotated by hand.)	<ul style="list-style-type: none"> • Connection of the motor to the driver. • ON/OFF status of the M.F signal. 	<ul style="list-style-type: none"> • Wiring error with the motor and the driver. • The M.F signal is input. • Driver failure.
3. The motor does not rotate. The motor behaves abnormally. The motor steps out.	<ul style="list-style-type: none"> • The same check items as those under item 2 above. • Setting of the MOTOR SELECT switch. • Connection of the pulse signal. • Voltage and wave form of the pulse signal. • Setting of the DRIVE CURRENT SELECT switch. • Setting of the STEP ANGLE SELECT switch. • ON/OFF status of the C.S signal. 	<ul style="list-style-type: none"> • Wrong setting for the motor selection. • Wiring error with the pulse signal line. • Pulse signal of wrong specifications. • DRIVE CURRENT is too low. • Wrong setting for the step angle. • The C.S signal is input. • Driver failure. • Motor failure.
4. The motor steps out during acceleration.	<ul style="list-style-type: none"> • Starting pulse speed. • Acceleration time. • Setting of HIGH-SPEED POWER OUTPUT SELECT switch. 	<ul style="list-style-type: none"> • Starting pulse signal speed is too high. • Acceleration time is too short. • Setting of HIGH-SPEED POWER OUTPUT SELECT switch is low power setting.
5. The motor generates excessive heat.	<ul style="list-style-type: none"> • Setting of the DRIVE CURRENT SELECT switch. • Setting of the HOLD CURRENT SELECT switch. • Setting of the MOTOR SELECT switch. 	<ul style="list-style-type: none"> • DRIVE CURRENT is higher than the setting for the applicable motor. • The setting for HOLD CURRENT is too high. • Wrong setting for the motor selection.
6. Overheat alarm signal is output.	<ul style="list-style-type: none"> • Ambient temperature around the driver. 	<ul style="list-style-type: none"> • Ambient temperature is too high (40°C or more).

Short-circuiting of the motor output terminal may cause the driver to fail.

- Short-circuiting between the motor output terminal and the earth terminal (PE)
- Short-circuiting between the motor output terminal and the power line
- Short-circuiting between the motor output terminal and the motor output terminal
- Wiring error or snapping of the motor output lines

When the failure phenomenon cannot be remedied, contact our office.

9. Storing and Disposal

9 – 1. Storing

(1) Keep the product in the following environment:

- Area that is free of explosive, corrosive or inflammable gas
- Indoors (Area not exposed to direct sunshine)
- Area that ambient temperature and humidity are controlled within the range set out in the specifications
- Area protected from dust, salt or iron particles
- Area not subject to direct vibration or shock
- Area not subject to splashing water, oil or chemicals

(2) Do not allow standing or placing anything heavy on the product.

9 – 2. Disposal

(1) Dispose of the product as industrial waste.

1 0. Specifications

1 0 – 1. General Specifications

Supply Power	Single-phase 100–115V(50/60Hz) *1 ●Rated power at DRIVE: 220VA [POWER SEL ⇒ HP, H set up] *2 ●Rated power at HOLD: 30VA [HOLD I. SEL ⇒ 40% set up]	
Motor output current	MOTOR SEL switch is set to [5L]	●DRIVE CURRENT 0.17A/phase~0.68A/phase (16 levels) ●HOLD CURRENT 10%~100% of DRIVE CURRENT (10 levels)
	MOTOR SEL switch is set to [10L]	●DRIVE CURRENT 0.34A/phase~1.35A/phase (16 levels) ●HOLD CURRENT 10%~100% of DRIVE CURRENT (10 levels)
Input Signal	●Drive pulse input (CW, CCW) -----	Photo-coupler input
	●Motor excitation stop input (M. F) -----	Photo-coupler input
	●Step angle switch input (C. S) -----	Photo-coupler input
Output Signal	●Phase signal output (P. O) -----	O/C output
	●Overheat alarm signal output (O. H. A) -----	O/C output
Function of Operating Sections	●MOTOR selection (MOTOR SEL) ●HIGH-SPEED POWER selection (POWER SEL) ●HOLD CURRENT selection (HOLD I. SEL) ●DRIVE CURRENT selection (DRIVE I. SEL) ●STEP ANGLE selection (STEP SEL) ●HOLD SWITCHING TIME selection (DHT SEL) ●ROTATE CHARACTERISTIC selection (RC SEL)	
Operating Ambient Temperature	0°C ~ +40°C (No freezing allowed)	
Operating Ambient Humidity	80%RH or less (No condensation allowed)	
Storing Temperature	-10°C ~ +55°C (No freezing allowed)	
Storing Humidity	80%RH or less (No condensation allowed)	
Atmosphere	Indoor (Exposure to direct sunshine is not allowed.) Without any explosive, corrosive or inflammable gas, oil mist, or dust	
Withstanding Vibration	No abnormality should be found after a vibration test at 10~55Hz, 0.15mm P-P.	
Insulated Withstanding Voltage	(At ordinary temperature and humidity)	
	AC terminal – signal terminal	1500VAC: for one minute 500VDC: 100MΩ or more
Insulation Resistance	AC terminal – ⊕ terminal	1500VAC: for one minute 500VDC: 100MΩ or more
Exterior Dimensions	^H 124.5 × ^W 130 × ^D 55 (mm) *3	
Weight	0.55 kg	

*1 Input voltage range is single-phase 100–115V±10%.

*2 Power demand varies with rotation speed, a load, etc.

*3 Including screws and terminal blocks.

1 0 – 2. Conforming to UL standards

R4

(1) Safety standards

UL508C

Warning for UL standards

- This product has no provision for motor over temperature protection.
Motor over temperature protection is required in the end use product.

● Installation conditions

	UL508C
Protective class:	I
Overvoltage category:	III
Pollution degree:	Class 2
Protective type:	IP-00

- This product is designed for use as a built-in component.
- Install the product within an enclosure in order to avoid contact with the hand.
- Securely ground the protective earth terminals.

1 0 - 3. I/O Signal

R3

(1) Example Circuit Connection

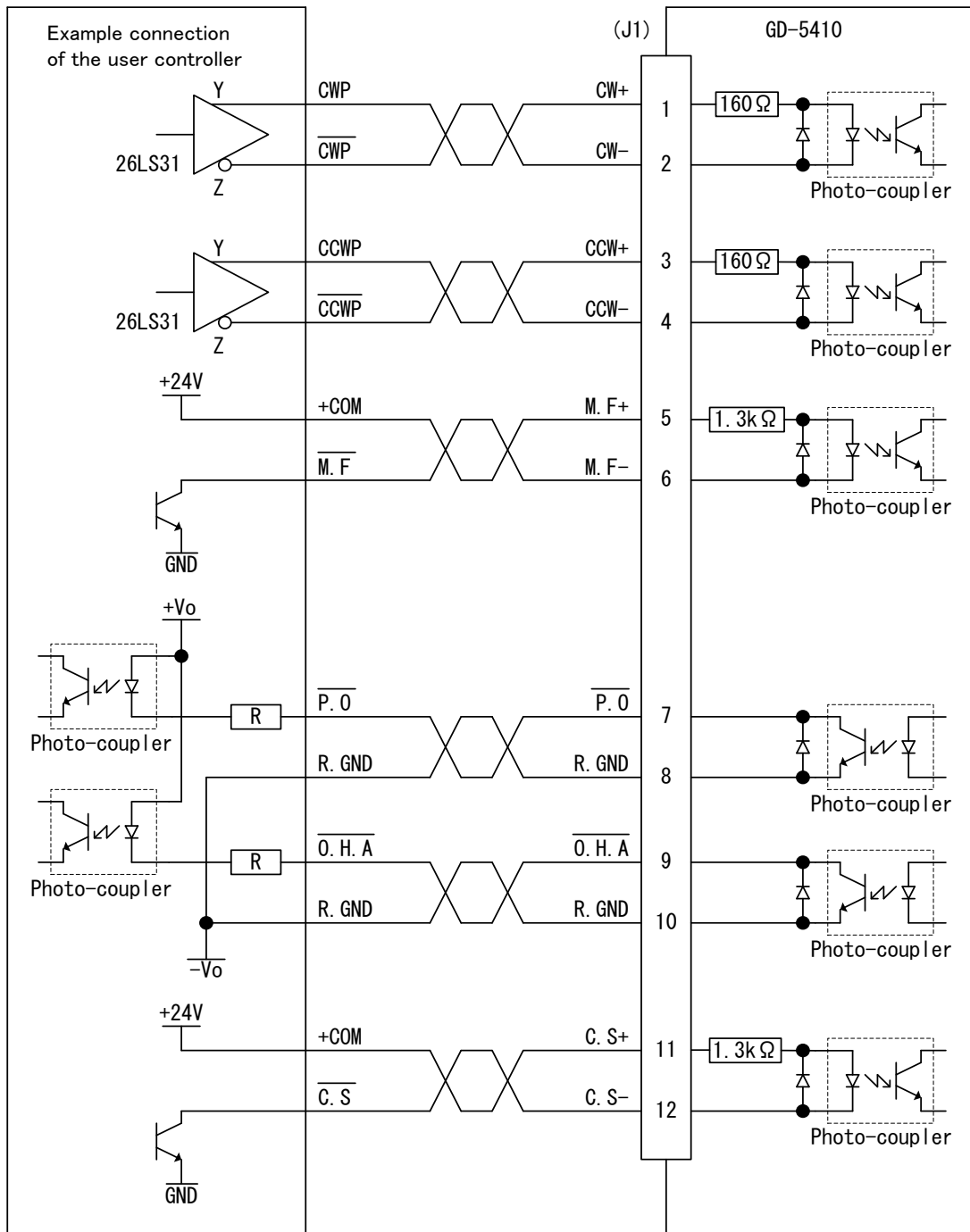

(2) Drive pulse input (CW, CCW)

- ① Operating current range : 9mA~27mA
 The photo-coupler turns on with inter-terminal voltage of 3.1 V~5.5 V.
 (Photo-coupler diode $V_F \doteq 1.6$ V)

② Timing chart

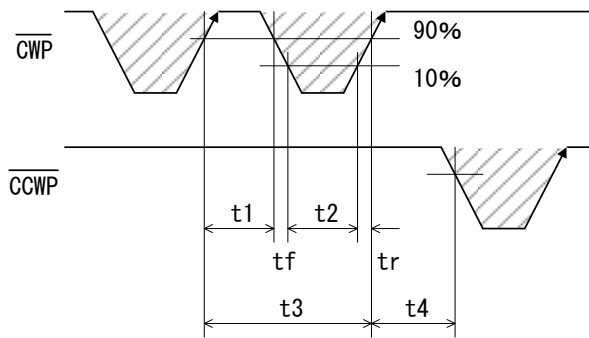

$t1 \geq 0.5 \mu s$, $t2 \geq 0.5 \mu s$, $t_f, t_r \leq 1 \mu s$
 $t3 > 1 \mu s$, $t4 > 1 \mu s$

Maximum response frequency : 1MHz

- The shaded area () indicates light emission from the photo-coupler, and the motor is driven at the rising edge ().
 "t4" greatly varies according to the inertial moment including that of the motor.

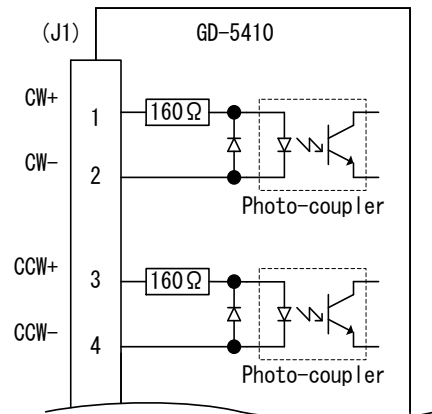

[To the line driver 26LS31]

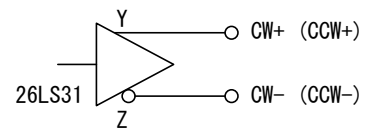

③ Automatic switching for DRIVE/HOLD

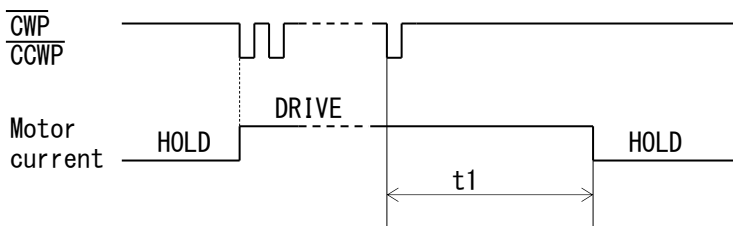

[DHT2, DHT1]	[OFF, OFF]	[OFF, ON]	[ON, OFF]	[ON, ON]
t1	150ms	16ms	8ms	4ms

- Inputting drive pulse causes the current output to the motor to change from HOLD CURRENT to DRIVE CURRENT, which returns to HOLD CURRENT in "t1".
 DRIVE CURRENT continues if pulse is input on driving-state.

④ Direction of rotation

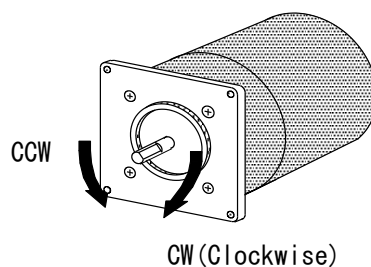

(3) Motor excitation stop input (M.F)

R3

CAUTION

Deterioration of the holding power with the motor may cause breakage of the machine or injury.
Check safety before inputting.

- ① Operating current range : 2.6mA~19.5mA
The photo-coupler turns on with inter-terminal voltage of 4.5V~26.4V.
(Photo-coupler diode $V_F \doteq 1.1\text{ V}$)

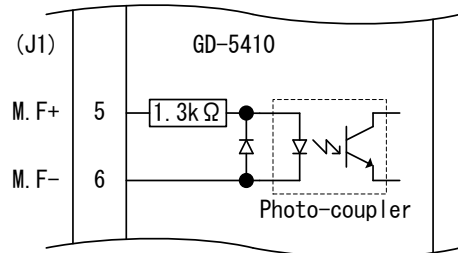

- Motor output current is shut off with the photo-coupler ON.
At this time, motor torque changes to detent torque.
- When this signal is input, motor torque may be lost, resulting in failure to retain the load transported.
In particular, this risk is high with the vertical drive (such as the Z-axis).

② Timing chart

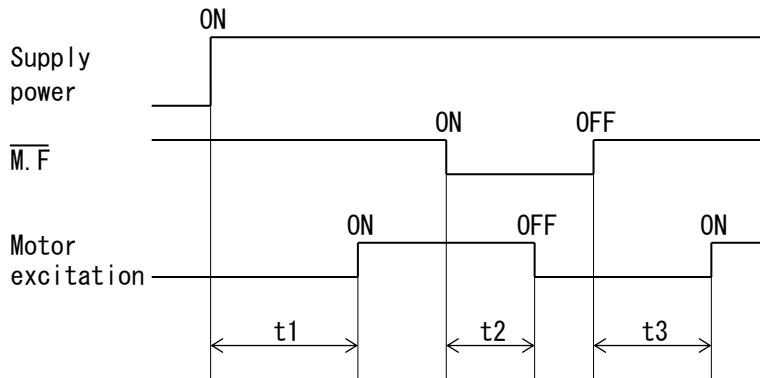

- $t1 \leq 1.5\text{s}$ ($t1$: Time required for the motor to be enabled.)
 $t2 \leq 5\text{ms}$ ($t2$: Time required for the motor output current to be shut off.)
 $t3 \leq 100\text{ms}$ ($t3$: Time required for the motor to be enabled.)

(4) Phase signal output (P.0)

R3

- ① Output current
- a. $I_C \leq 6\text{mA}$, $V_{CE} < 2\text{V}$
 - b. $I_C \leq 2\text{mA}$, $V_{CE(sat)} < 0.6\text{V}$
 $V_{CEO} \leq 30\text{V}$

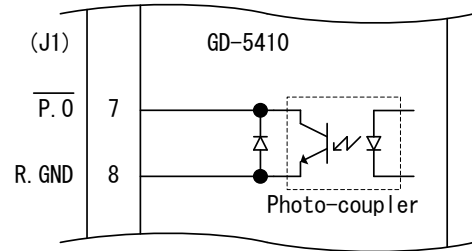

- In case of the excitation home position, the signal is output.
(photo-coupler ON)
- In case of simultaneously using P.0 signal and C.S signal,
input C.S signal while P.0 signal is being output to switch the step angle.
Otherwise, P.0 signal may not be output.

② Timing chart

- P.0 output timing (for 1/1 STEP)

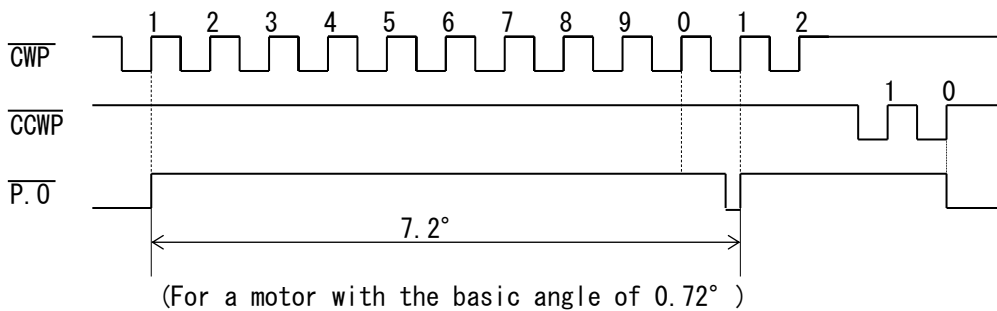

- P.0 output time

1/1 STEP: once in 10 pulses	1/40 STEP: once in 400 pulses
1/2 STEP: once in 20 pulses	1/100 STEP: once in 1000 pulses
1/4 STEP: once in 40 pulses	1/200 STEP: once in 2000 pulses
1/10 STEP: once in 100 pulses	1/400 STEP: once in 4000 pulses
1/20 STEP: once in 200 pulses	1/800 STEP: once in 8000 pulses

(5) Overheat alarm signal output (O. H. A)

R3

 WARNING
Overheating may cause fire. Stop operation upon output of this signal.

- ① Output current
- a. $I_C \leq 6\text{mA}$, $V_{CE} < 2\text{V}$
 - b. $I_C \leq 2\text{mA}$, $V_{CE(\text{sat})} < 0.6\text{V}$
 $V_{CE0} \leq 30\text{V}$

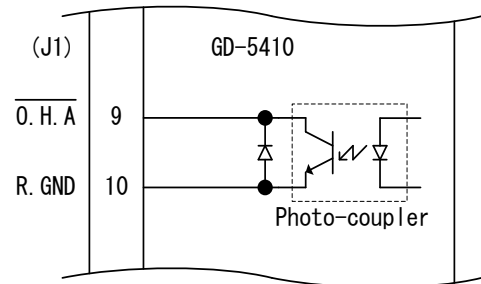

- Use overheat alarm signal output (O. H. A) without fail.
- In case of internal temperature of the driver reaches approx. 70°C or more, this signal is output (photo-coupler ON) and O. H. A LED comes on. At this time the motor output current is not blocked.
- When this signal is output, stop operation and check if there is any abnormality occurring with the motor and the driver.
- Perform the cooling measure of the mounting plate is enlarged or compulsion air cooling, for example, if this signal is output while no abnormality is detected.
- Continuous operation is possible unless this signal is output.

(6) Step angle switch input (C.S)

R3

- ① Operating current range : 2.6mA~19.5mA
 The photo-coupler turns on with inter-terminal voltage of 4.5V~26.4V.
 (Photo-coupler diode $V_F \doteq 1.1\text{ V}$)

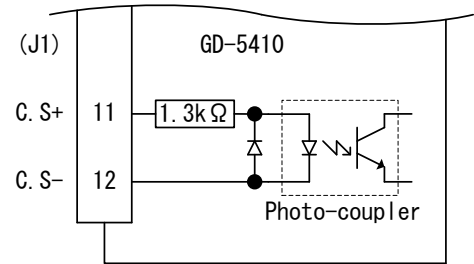

- Step angle division is switched to 1/20 divisions with the photo-coupler ON.
 The setting for the STEP ANGLE SELECT switch is ignored.
- No displacement occurs even if the step angle is switched by the C.S signal.

② Timing chart

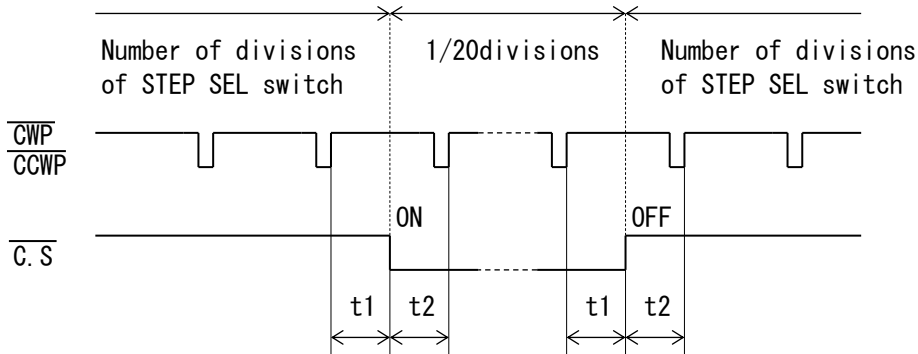

$t1 \geq 30\text{ms}$
 $t2 \geq 1\text{ms}$

- Switching the step angle by the C.S signal requires time t1 and t2 before and after inputting drive pulse.

③ STEP ANGLE SELECT switch and C.S signal

[STEP ANGLE SELECT switch]

Switch No.	Number of Divisions	Step angle (°) 0.72° motor
0	1/1	0.72
1	1/2	0.36
2	1/4	0.18
3	1/10	0.072
4	1/20	0.036
5	1/40	0.018
6	1/100	0.0072
7	1/200	0.0036
8	1/400	0.0018
9	1/800	0.0009

[When the C.S signal is input]



1/20 divisions
(0.036°)

1 0 - 4. Dimensions

R4

(Unit : mm)

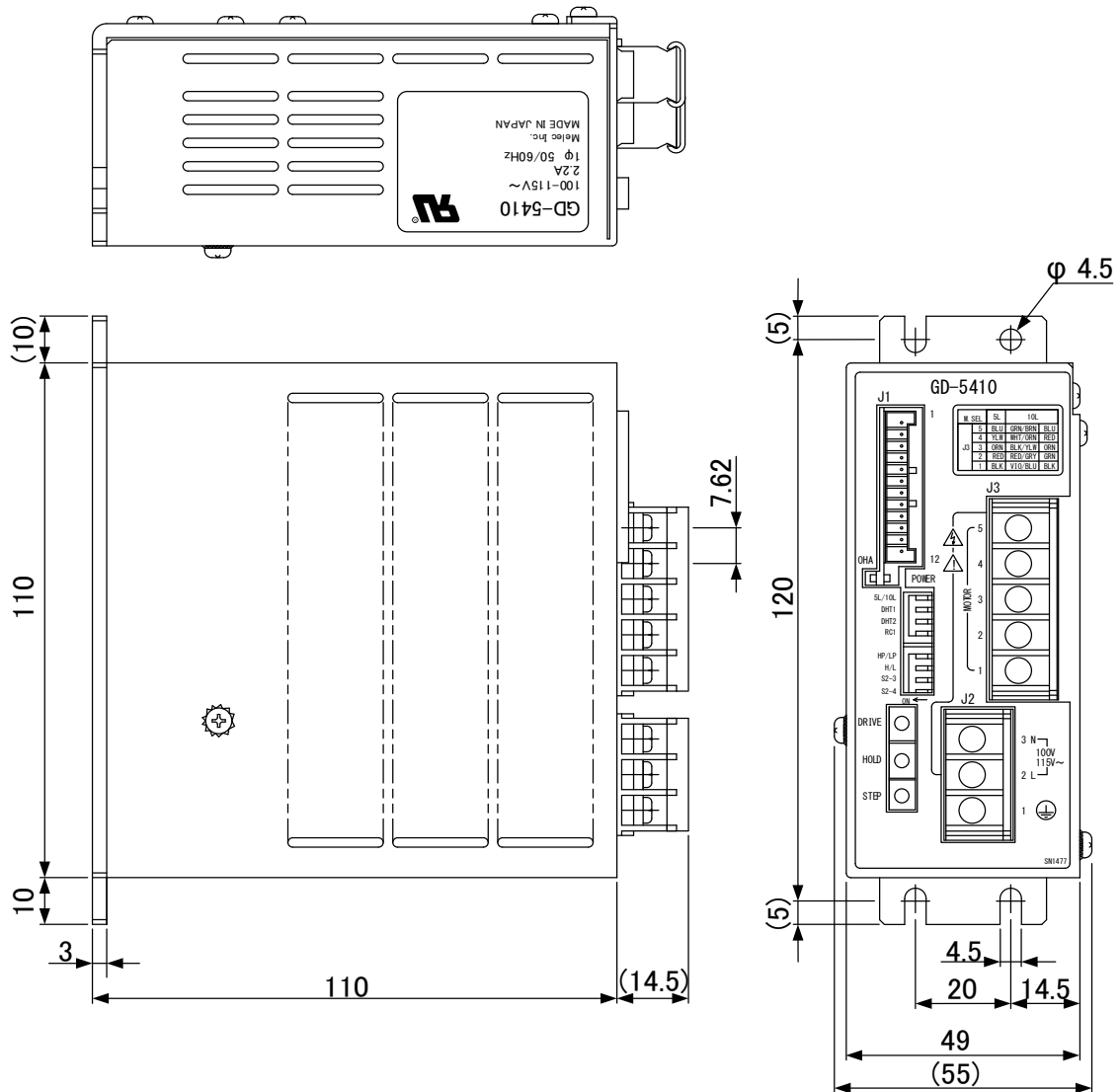

1 0 – 5. Applicable Motors

- Applicable motors are 5-phase stepping motors ranging from 0.75A/phase ~ 1.4A/phase.

Representative Motors	Basic Angle (°)	Current (A/phase)	Setting DRIVE I. SEL switch No.	Setting MOTOR SEL switch	Torque Data Fig. No.			
ORIENTAL MOTOR CO., LTD.	0.72	0.75	6	OFF (10L)	Fig. 1 Fig. 2 Fig. 3 Fig. 4 Fig. 5			
PK543-A (B) PK544-A (B) PK545-A (B) PK564-A (B) PK566-A (B)								
PK564H-A (B) PK566H-A (B) PK569-A (B)								
PK596-A (B) PK599-A (B)								
TAMAGAWA SEIKI CO., LTD.								
TS3667N1E2 (N11E2) TS3667N2E5 (N12E5) TS3667N3E7 (N13E7)	0.72	0.75	6	OFF (10L)	Fig. 11 Fig. 12 Fig. 13			
SANYO DENKI CO., LTD.	0.72	0.75	F	ON (5L)	Fig. 14 Fig. 15 Fig. 16			
103H5505-7040 (7010) 103H5508-7040 (7010) 103H5510-7040 (7010)								
103H6500-7041 (7011) 103H6501-7041 (7011)								
103H7851-7051 (7021) 103H7852-7051 (7021) 103H7853-7051 (7021)								
103H8581-7041 (7011) 103H8582-7041 (7011)								
Factory setting						F	OFF (10L)	—

() : Both axes

1 0 – 6. Torque Characteristics

- (1) Representations in the torque characteristics table are made in terms of the motor rotation speed (s^{-1}) vs. torque ($N \cdot m$).

Motor rotation speed (s^{-1}) and drive pulse frequency (Hz) are converted as follows:

$$\text{Motor rotation speed (s}^{-1}\text{)} \times \frac{360^\circ}{\text{Step angle}} = \text{Drive pulse input frequency (Hz)}$$

- Maximum value of the rotation speed is $60s^{-1}$ at 0.72° motor.
- (2) The Maximum Starting Pulse Rate is represented as "fs" by the value at zero inertial load.
- (3) Upon operation, provide adequate allowance for torque.
- (4) The stepping motor may attain high temperature, depending on the operational conditions.
Use the stepping motor according to the Instructions Manual produced by motormakers.

Fig. 1

PK543-A (B)
0.75A/PHASE

MOTOR SEL = 10L
DRIVE I. SEL = No. 6
AC100V

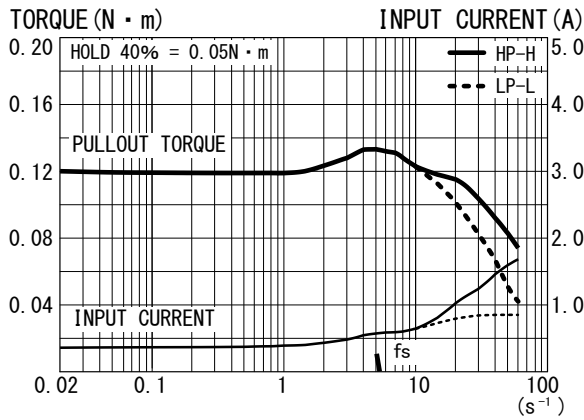

Fig. 2

PK544-A (B)
0.75A/PHASE

MOTOR SEL = 10L
DRIVE I. SEL = No. 6
AC100V

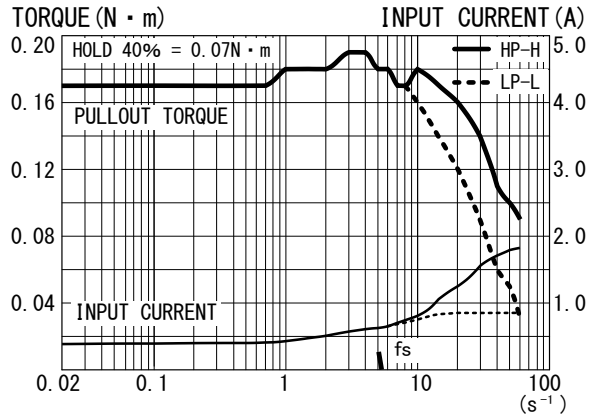

Fig. 3

PK545-A (B)
0.75A/PHASE

MOTOR SEL = 10L
DRIVE I. SEL = No. 6
AC100V

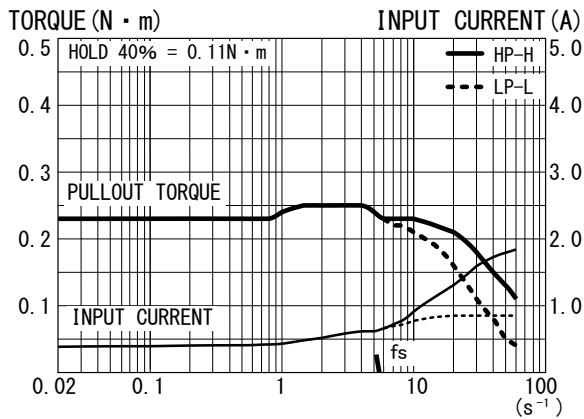

Fig. 4

PK564-A (B)
0.75A/PHASE

MOTOR SEL = 10L
DRIVE I. SEL = No. 6
AC100V

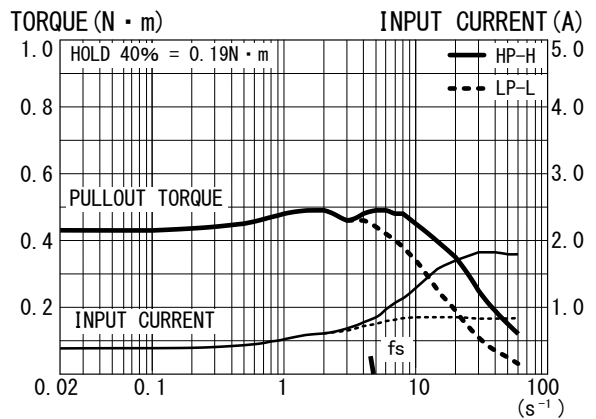

Fig. 5

PK566-A (B)
0.75A/PHASE

MOTOR SEL = 10L
DRIVE I. SEL = No. 6
AC100V

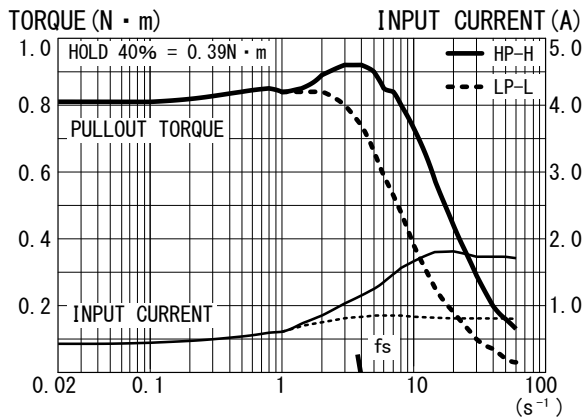

Fig. 6

PK564H-A (B)
1.4A/PHASE

MOTOR SEL = 10L
DRIVE I. SEL = No. F
AC100V

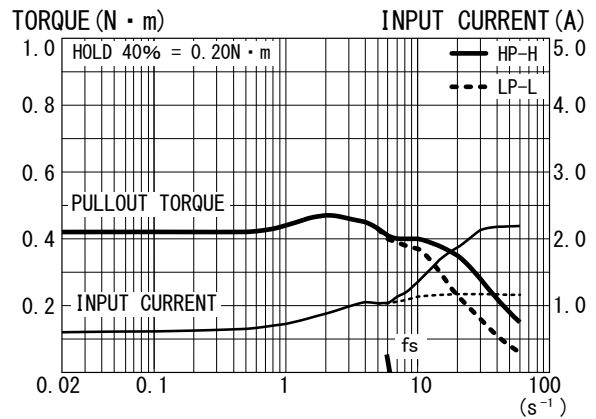

Fig. 7

PK566H-A(B)
1.4A/PHASE

MOTOR SEL = 10L
DRIVE I. SEL = No. F
AC100V

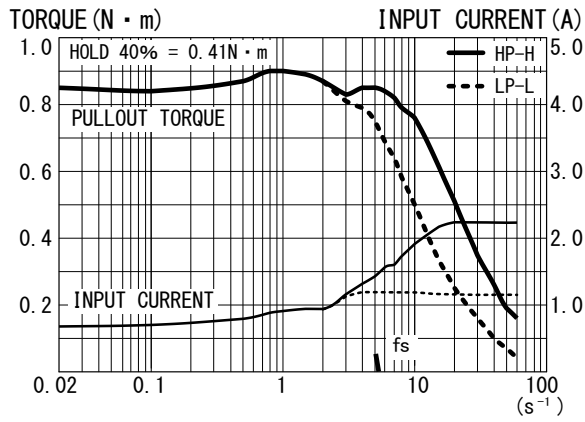

Fig. 8

PK569-A(B)
1.4A/PHASE

MOTOR SEL = 10L
DRIVE I. SEL = No. F
AC100V

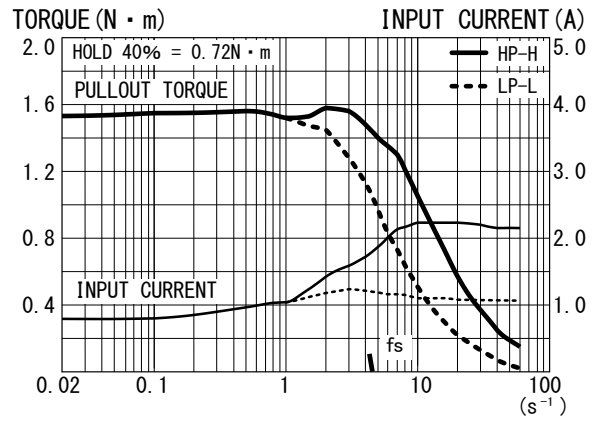

Fig. 9

PK596-A(B)
1.4A/PHASE

MOTOR SEL = 10L
DRIVE I. SEL = No. F
AC100V

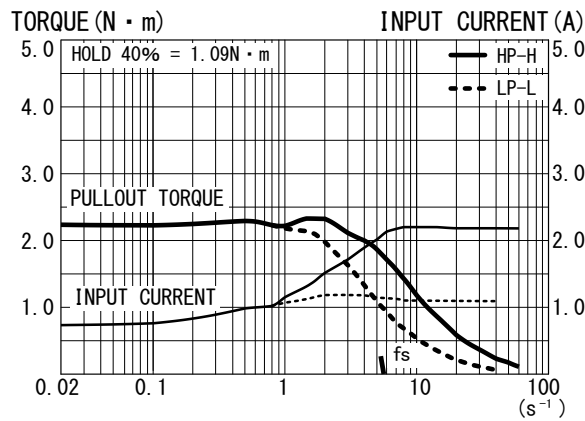

Fig. 10

PK599-A(B)
1.4A/PHASE

MOTOR SEL = 10L
DRIVE I. SEL = No. F
AC100V

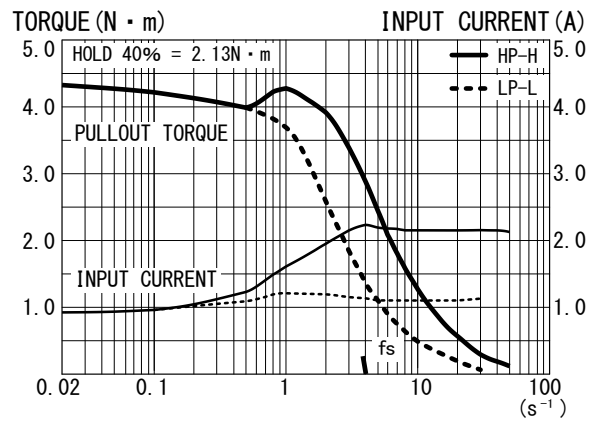

Fig. 11

TS3667N1E2 (N11E2)
0.75A/PHASE

MOTOR SEL = 10L
DRIVE I. SEL = No. 6
AC100V

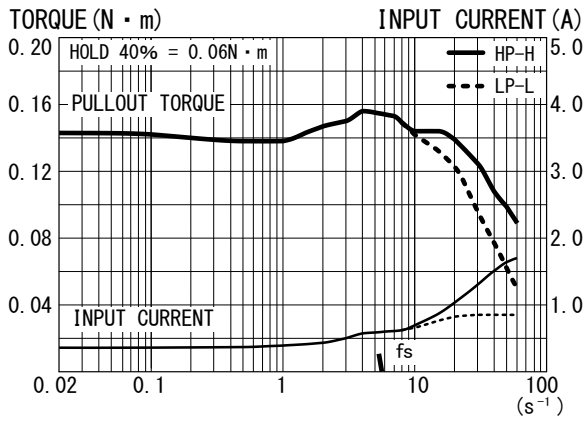

Fig. 12

TS3667N2E5 (N12E5)
0.75A/PHASE

MOTOR SEL = 10L
DRIVE I. SEL = No. 6
AC100V

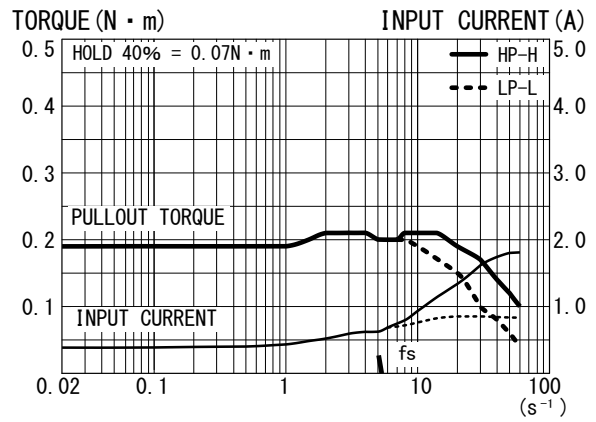

Fig. 13

TS3667N3E7 (N13E7)
0.75A/PHASE

MOTOR SEL = 10L
DRIVE I. SEL = No. 6
AC100V

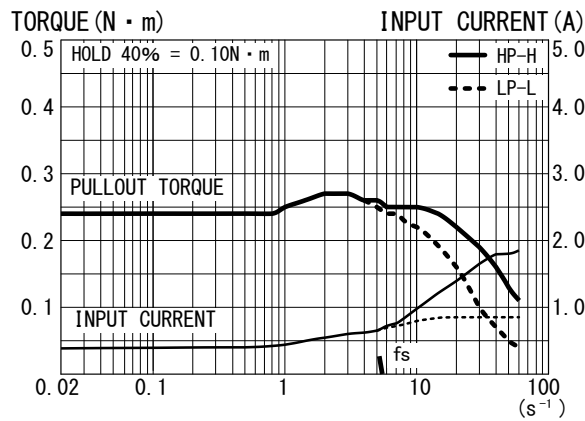

Fig. 14

103H5505-7040 (7010)
0.75A/PHASE

MOTOR SEL = 5L
DRIVE I. SEL = No. F
AC100V

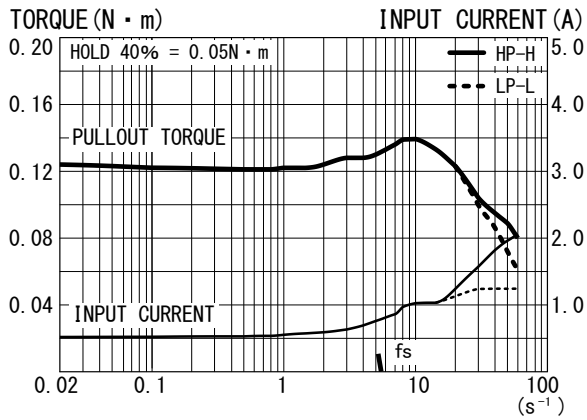

Fig. 15

103H5508-7040 (7010)
0.75A/PHASE

MOTOR SEL = 5L
DRIVE I. SEL = No. F
AC100V

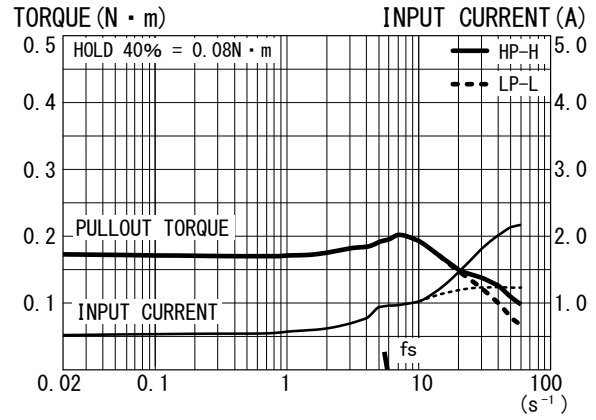

Fig. 16

103H5510-7040 (7010)
0.75A/PHASE

MOTOR SEL = 5L
DRIVE I. SEL = No. F
AC100V

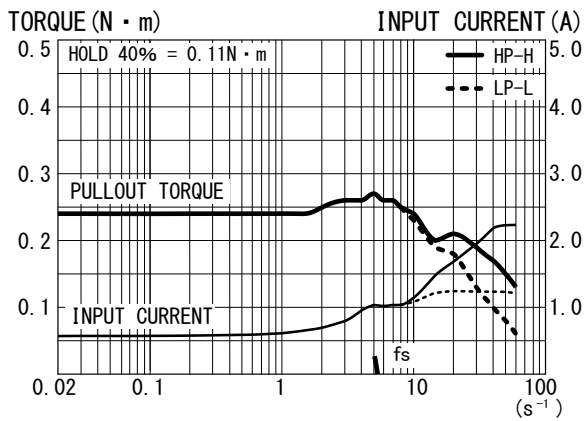

Fig. 17

103H6500-7041 (7011)
0.75A/PHASE

MOTOR SEL = 5L
DRIVE I. SEL = No. F
AC100V

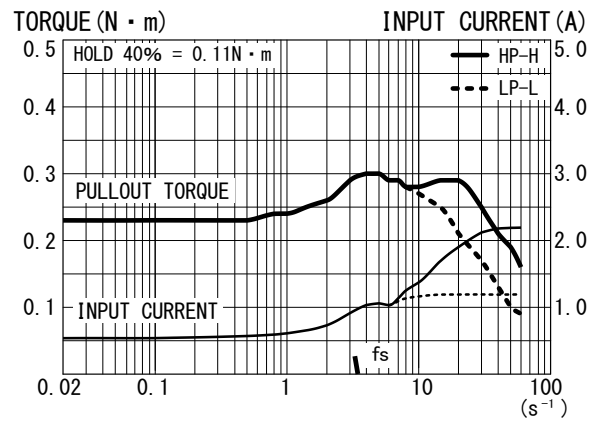

Fig. 18

103H6501-7041 (7011)
0.75A/PHASE

MOTOR SEL = 5L
DRIVE I. SEL = No. F
AC100V

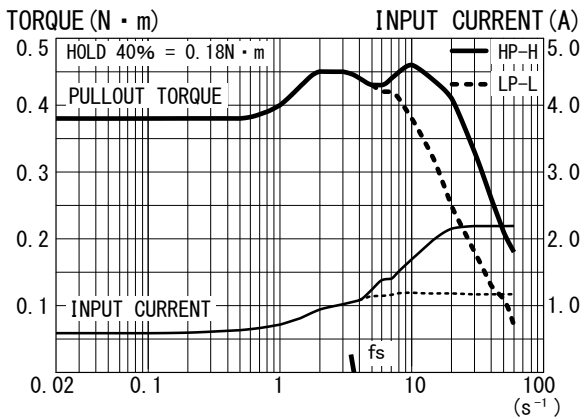

Fig. 19

103H7851-7051 (7021)
0.75A/PHASE

MOTOR SEL = 5L
DRIVE I. SEL = No. F
AC100V

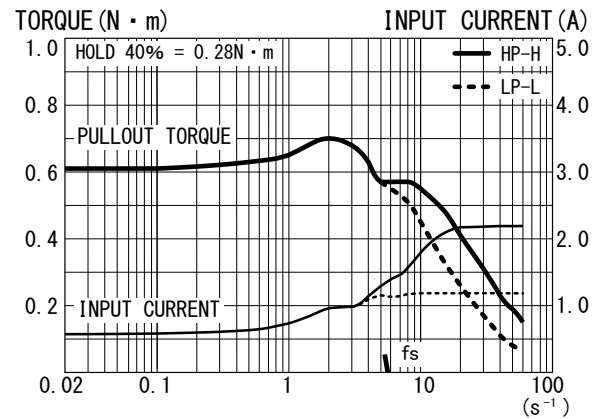

Fig. 20

103H7852-7051 (7021)
0.75A/PHASE

MOTOR SEL = 5L
DRIVE I. SEL = No. F
AC100V

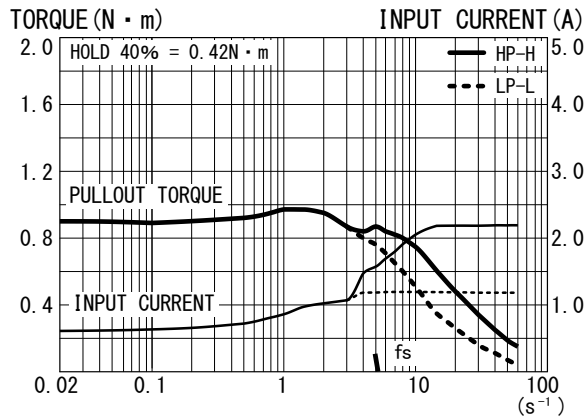

Fig. 21

103H7853-7051 (7021)
0.75A/PHASE

MOTOR SEL = 5L
DRIVE I. SEL = No. F
AC100V

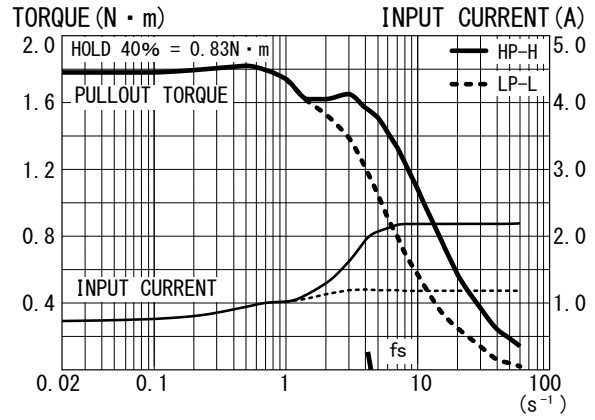

Fig. 22

103H8581-7041 (7011)
0.75A/PHASE

MOTOR SEL = 5L
DRIVE I. SEL = No. F
AC100V

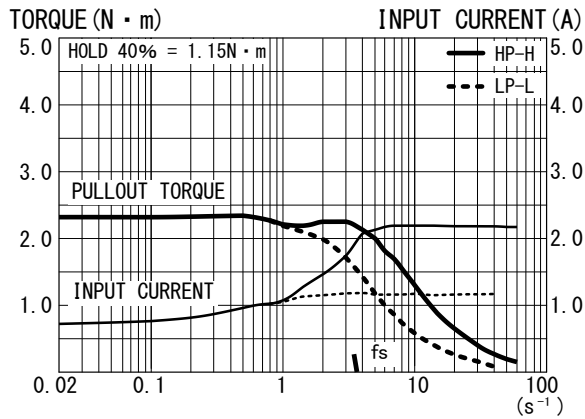
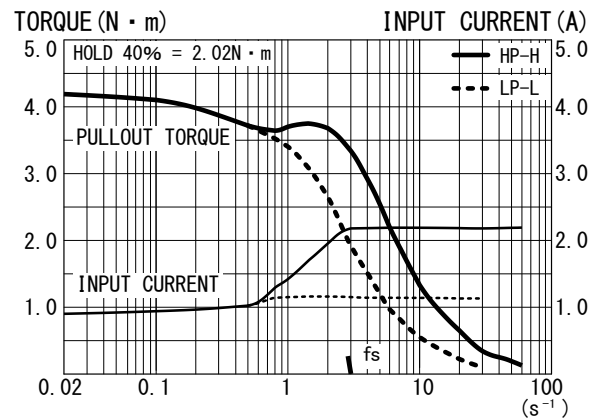

Fig. 23

103H8582-7041 (7011)
0.75A/PHASE

MOTOR SEL = 5L
DRIVE I. SEL = No. F
AC100V



The main parts which revised by this manual

Parts	Content
P5, P47 P33, P35, P36, P37, P38	【R3】 Addition of 「The main parts which revised by this manual」 Revision of the signal I/O
P1, P5, P11, P32, P39	【R4】 Withdrawal of the CE marking declaration by the abolition of the EN50178 standard. Deletion of the TÜV-mark and the CE-mark.

Technical Service

TEL. (042) 664-5382 FAX. (042) 666-5664
E-mail s-support@melec-inc.com

Sales and Service

TEL. (042) 664-5384 FAX. (042) 666-2031
URL:www.melec-inc.com

Melec Inc. Control equipment marketing department
516-10, Higashiasakawa-cho, Hachioji-shi, Tokyo 193-0834, Japan

This Operating Manual is subject to change without prior notice
for the purpose of product improvement.