

# Melec



5-phase Stepping Motor Driver

# GD-5410v1

## Instructions Manual (For designers' use)

# USER'S MANUAL

Please ensure to read and understand this Instructions Manual before using the product.  
Please keep this Instructions Manual at hand



MN0380

## **Introduction**

This Instructions Manual describes the safe and proper method of handling '5-phase Stepping Motor Driver GD-5410v1' with emphasis on the specifications, assuming that our readers are engaged in designing of control devices incorporating stepping motors.

Please ensure to read and understand this Instructions Manual before using the product.

Please keep this Instructions Manual at hand so that it is always available for reference.

## **Descriptions in this manual on safety matters:**

This product must be operated and used properly.

Otherwise, or when it is operated and used erroneously, unforeseen accidents may occur, causing physical injuries or property damages.

Majority of these accidents can be avoided if you are well informed of hazardous circumstances in advance.

Consequently, this instructions manual describes all the hazardous and dangerous circumstances and situations which can be foreseen and anticipated as well as necessary precautions.

All the above descriptions are being titled by the following symbol-marks and signal-words, namely:



Represents warnings ignorance of which can cause accidents involving fatal or serious physical injuries, or death.



Represents cautions ignorance of which can cause accidents involving minor physical injuries or property damages.

## Introduction

Descriptions in this manual on safety matters:

	CONTENTS	PAGE
<b>1. Safety</b>		
1-1. Safety Precautions .....		6
1-2. Safety Information for Handling .....		7
<b>2. Overview</b>		
2-1. Characteristics .....		11
2-2. Product Configuration .....		11
2-3. Appearance .....		11
<b>3. Name and Function of Each Section</b>		
3-1. Signal I/O Connector (J1) .....		12
3-2. AC Input/Motor Output Terminal Block (J2, J3) .....		13
3-3. POWER LED .....		13
3-4. O. H. A LED .....		13
3-5. Operating Section .....		14
<b>4. Setting</b>		
4-1. Setting STEP ANGLE SELECT switch .....		15
4-2. Setting HOLD CURRENT SELECT switch .....		16
4-3. Setting DRIVE CURRENT SELECT switch .....		17
4-4. Setting HOLD SWITCHING TIME SELECT switch .....		18
4-5. Setting ROTATE CHARACTERISTIC SELECT switch .....		18
4-6. Setting PULSE INPUT TYPE SELECT switch .....		19
4-7. Setting MOTOR SELECT switch .....		19
<b>5. Installation</b>		
5-1. Conditions for Installation .....		20
5-2. Mounting Method .....		21
<b>6. Connection</b>		
6-1. Overview of Connection Configuration .....		22
6-2. Connecting Signal I/O Connector (J1) .....		23
6-3. Connecting AC Input/Motor Output Terminal Block (J2, J3) .....		24
6-4. Inputting Power .....		27
<b>7. Confirmation of Setting and Connection</b>		
7-1. Check Points .....		28

	PAGE
<b>8. Maintenance and Check-up</b>	
8-1. Maintenance and Check-up .....	29
8-2. Troubleshooting .....	30
<b>9. Storing and Disposal</b>	
9-1. Storing .....	31
9-2. Disposal .....	31
<b>10. Specifications</b>	
10-1. General Specifications .....	32
10-2. Conforming to Europe standards and UL standards .....	33
10-3. I/O Signal	
(1) Example Circuit Connection .....	34
(2) Drive pulse input (CW, CCW) .....	35
(3) Motor excitation stop input (M.F) .....	36
(4) Phase signal output (P.O) .....	37
(5) Overheat alarm signal output and overheat alarm LED (O.H.A) .....	38
(6) Step angle switch input (C.S) .....	39
10-4. Dimensions .....	40
10-5. Applicable Motors .....	41
10-6. Torque Characteristics .....	42

The main parts which revised by this manual

## 1. Safety

### 1 – 1. Safety Precautions

 <b>WARNING</b>
--

- (1) This product is not designed or manufactured for application for equipment requiring high level of reliability such as equipment related to nuclear energy, aeronautics-related equipment, automobiles, ships, medical appliances directly handling the human body and equipment that might seriously affect properties.
- (2) Do not use or keep the product in explosive or corrosive environments, in the presence of flammable gases, locations subjected to splashing water, fine particles, soot, steam, or exposed to radiation or direct sunshine. Doing so may cause electric shock, injury or fire.
- (3) This product is designed for use within machinery, so it should be installed within an enclosure.  
Be sure to ground the protective earth terminal of the driver.
- (4) Do not transport, move, install the product, perform connections or inspections when the power is on.  
Doing so may cause electric shock, injury or fire.
- (5) Only qualified personnel are allowed to transport, move, install the product, perform connections or inspections.  
Failure to do so may cause electric shock, injury or fire.

 <b>CAUTION</b>
--

- (6) Do not touch the driver during operation or immediately after stopping.  
Doing so may cause burn on the skin due to overheating of the driver.
- (7) Ensure to use this product according to the method specified in the Instructions Manual and within the specifications.
- (8) Depending on the operational conditions, the stepping motor may step out when it is on holding-state or driving-state.  
In particular, the load in transport may fall if the motor steps out on the vertical drive (such as the Z-axis).  
Start operation after test run for deliberate confirmation of operation.
- (9) Provide fail-safe measures so that the entire system may operate in a safe mode even in cases of the external power supply failure, disconnection of the signal line, or any failure on the driver.



## 1 – 2. Safety Information for Handling

## ●Overall:

 **WARNING**

Do not touch the driver during operation.  
Failure to do so may cause electric shock.

 **WARNING**

The marks,  and , on the front panel indicate terminals on which power voltage is applied.  
Do not touch such terminals while inputting power and while POWER LED is on.  
Doing so may cause electric shock.

 **WARNING**

Use only an insulated screwdriver to adjust or set internal switches.  
Failure to do so may cause electric shock.

 **CAUTION**

Do not touch the driver during operation or immediately after stopping.  
Doing so may cause burn on the skin due to overheating of the driver.

## ●When connecting the AC Input/Motor Output Terminal Block (J2, J3):

 **WARNING**

Turn the main power OFF.  
Failure to do so may cause electric shock.

 **WARNING**

Securely ground the protective earth terminal .

Failure to do so may cause electric shock.

 **WARNING**

Do not force the power line or the motor line to be bent or pulled or pinched.  
Doing so may cause electric shock or fire.

**⚠ CAUTION**

Erroneous connection may result in breakage of the motor or the driver. Correctly connect the motor wiring.

- When setting up the STEP ANGLE SELECT switch:

**⚠ CAUTION**

Erroneous setting may cause breakage of the machine or injury due to unexpected rotation of the motor. Ensure correct setting.

- When setting up the HOLD CURRENT SELECT switch:

**⚠ CAUTION**

A high setting value may cause burn on the skin due to overheating of the motor. Do not select a high value beyond the required.

- When setting up the DRIVE CURRENT SELECT switch:

**⚠ CAUTION**

Erroneous setting may cause burn on the skin due to overheating of the motor. Ensure correct setting.

- When setting up the PULSE INPUT TYPE SELECT switch:

**⚠ CAUTION**

Erroneous setting may cause breakage of the machine or injury due to unexpected rotation of the motor. Ensure correct setting.

- When setting up the MOTOR SELECT switch:

**⚠ CAUTION**

Erroneous setting may cause burn on the skin due to overheating of the motor. Ensure correct setting.



- When inputting the motor excitation stop (M.F) signal:

 CAUTION

Deterioration of the holding power with the motor may cause breakage of machine or injury.  
Check safety before inputting.

- When installing:

 WARNING



Overheating may cause fire.  
Mount it on a noncombustible member.  
Keep it away from combustibles.

- When inputting power:

 WARNING

Do not contact with a wet hand.  
Doing so may cause electric shock.

 WARNING

The marks,  and , on the front panel indicate terminals on which power voltage is applied.  
Do not touch such terminals while inputting power and while POWER LED is on.  
Doing so may cause electric shock.

 CAUTION

Unexpected behavior of the motor may cause breakage of the machine or injury.  
Maintain the state where emergency stop is enabled at any time.

- When the overheat alarm (O.H.A) signal is output:

 WARNING

Overheating may cause fire.  
Stop operation upon output of this signal.

- When the overheat alarm (O. H. A) LED comes on

**⚠ WARNING**

Overheating may cause fire.  
Stop operation when this LED comes on.

- When performing maintenance and checking:

**⚠ WARNING**

Only qualified personnel are allowed to perform maintenance and checking.  
Failure to do so may cause electric shock.

**⚠ WARNING**

Do not contact with a wet hand.  
Doing so may cause electric shock.

**⚠ WARNING**

The marks, ⚠ and ⚠, on the front panel indicate terminals on which power voltage is applied.  
Do not touch such terminals while inputting power and while POWER LED is on.  
Doing so may cause electric shock.

**⚠ WARNING**

Do not replace fuse.  
Do not disassemble, repair or modify.  
Doing so may cause electric shock, injury or fire.

## 2. Overview

### 2-1. Characteristics

GD-5410v1 is a driver for a 5-phase stepping motor with single-phase 100-115V input. Ten step angles can be selected from angles ranging from a 1/1 division to a 1/800 division of the basic angle. HOLD CURRENT and DRIVE CURRENT can be set up.

- Applicable motors and setting for each motor are given in the table "10-5. Applicable Motors".

### 2-2. Product Configuration

The product consists of the main frame and the accessories.

- GD-5410v1 One unit  
(Complete with terminal block covers)
- Housing for J1 (51103-1200:Molex) One unit (accessory)
- Contact for J1 (50351-8100:Molex) 14 contacts (accessories, 2 for spares)

### 2-3. Appearance

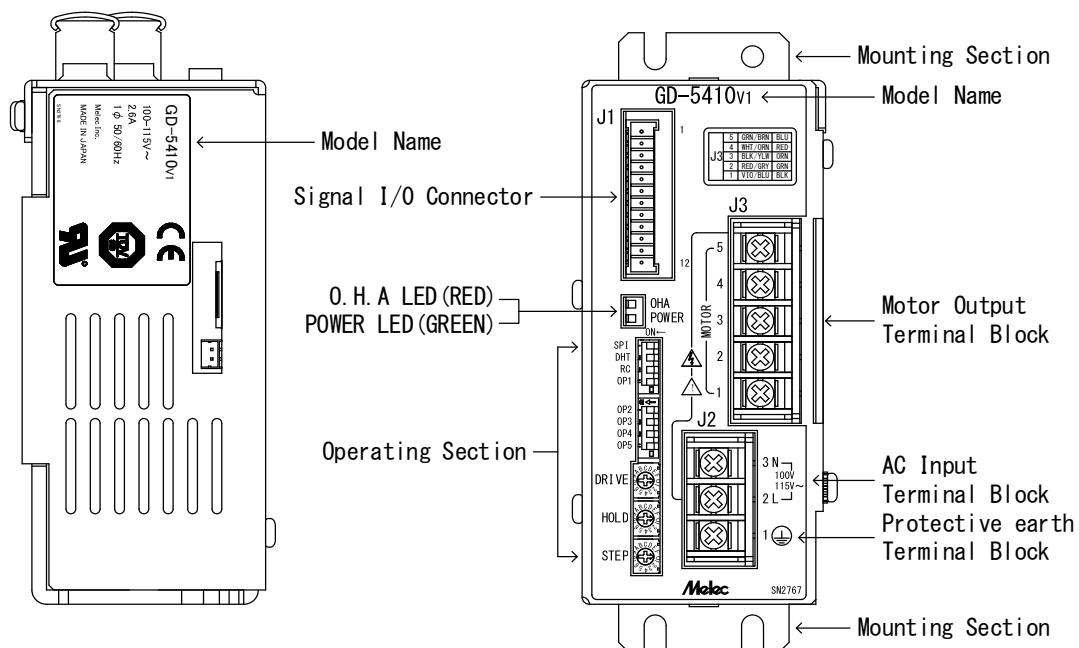

### 3. Name and Function of Each Section

#### 3-1. Signal I/O Connector (J 1)

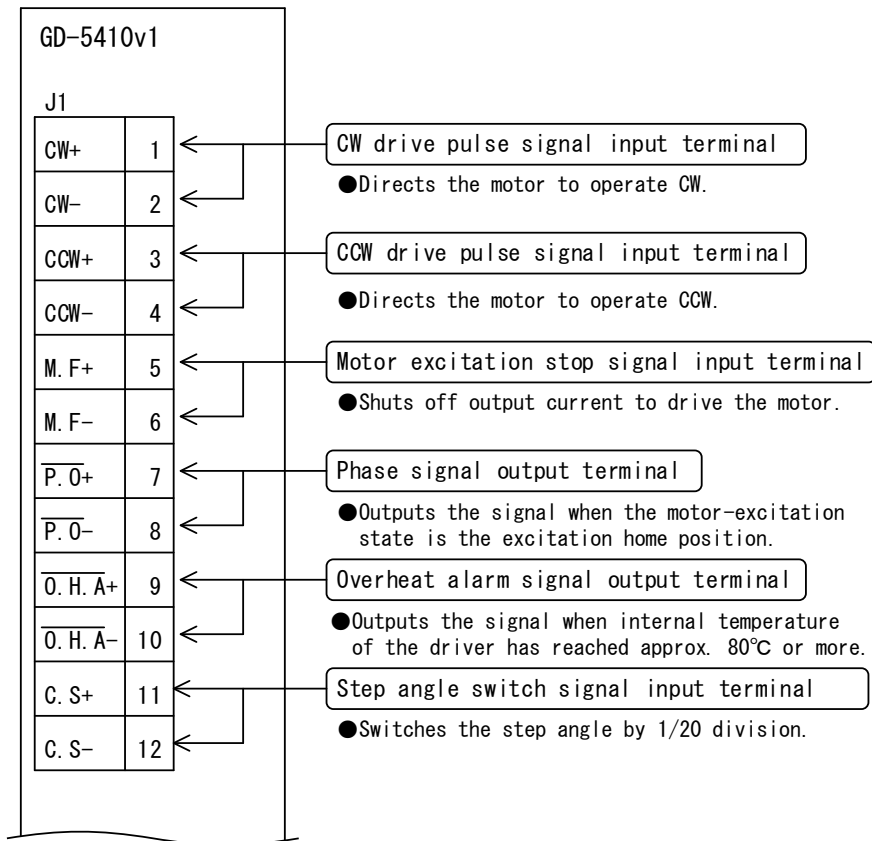

## 3 – 2. AC Input/Motor Output Terminal Block ( J 2, J 3 )

**⚠ WARNING**

Do not touch the driver during operation.  
Failure to do so may cause electric shock.

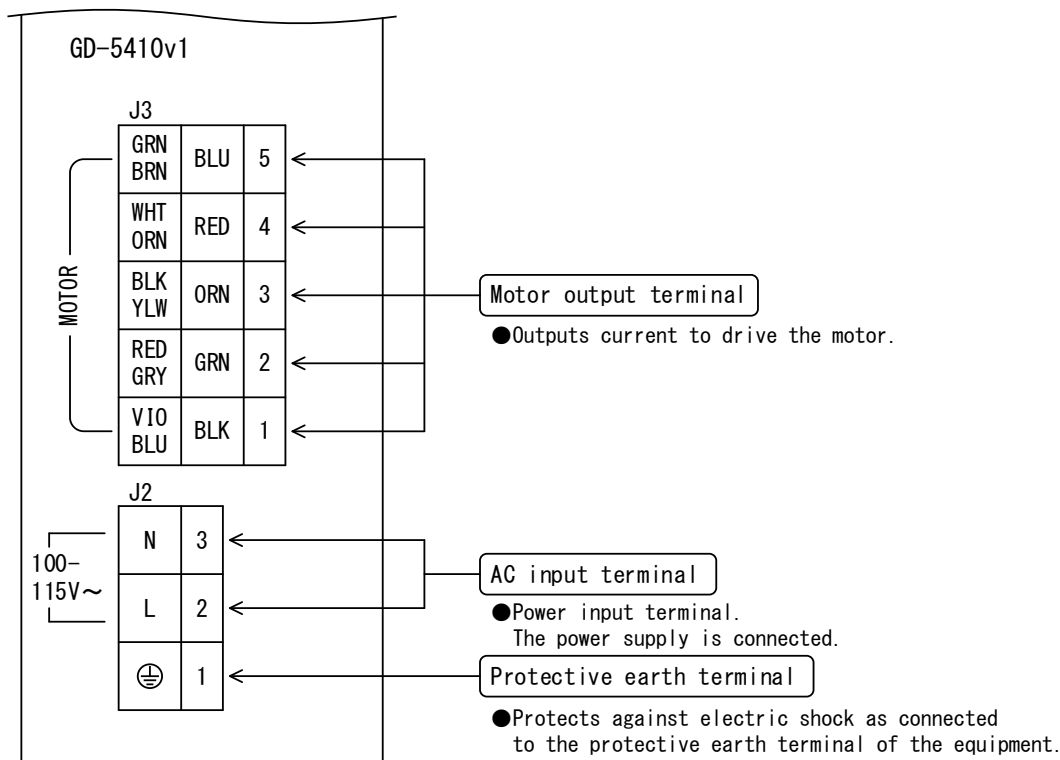

## 3 – 3. POWER LED

POWER LED (GREEN) comes on upon inputting power.

## 3 – 4. O. H. A LED

O. H. A LED (RED) comes on when internal temperature of the driver has reached approx. 80°C or more.

3 – 5. Operation Section

**⚠ WARNING**

Do not touch the driver during operation.  
 Failure to do so may cause electric shock.

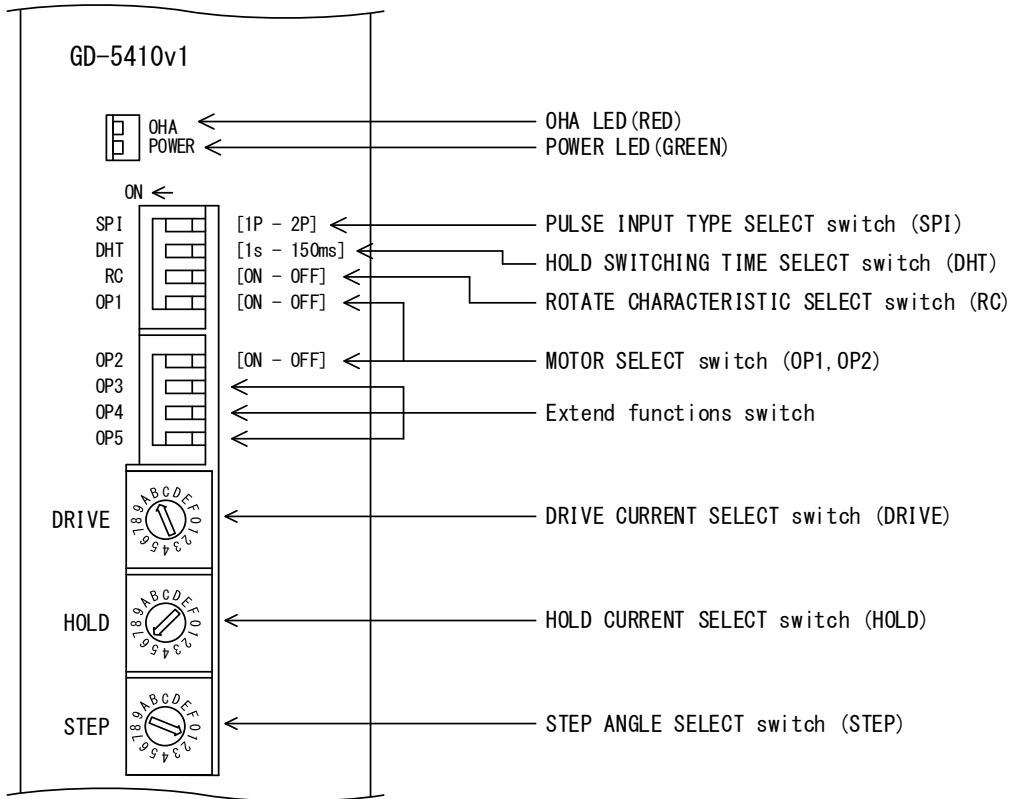

Name of Operation Section	Function	Factory Setting	
PULSE INPUT TYPE CELECT switch	Selects a pulse input type.	OFF	
HOLD SWITCHING TIME SELECT switch	DRIVE/HOLD CURRENT automatic switching time is selected.	OFF	
ROTATE CHARACTERISTIC SELECT switch	Please use it with OFF.	OFF	
MOTOR SELECT switch	Selects the applicable motor.	OP1	ON
		OP2	ON
Extend functions switch	Please use it with OFF.	OP3	OFF
		OP4	
		OP5	
DRIVE CURRENT SELECT switch	Selects DRIVE CURRENT.	No. B	
HOLD CURRENT SELECT switch	Selects HOLD CURRENT.	No. 6	
STEP ANGLE SELECT switch	Selects a step angle.	No. 1	

## 4. Setting

### 4 – 1. Setting STEP ANGLE SELECT switch

**⚠ CAUTION**

Erroneous setting may cause breakage of the machine or injury due to unexpected rotation of motor.  
Ensure correct setting.

The step angle is set up with the [STEP] switch.

(1) Set the [STEP] switch No. to the step angle required.

● Relationship between the [STEP] switch No. and the step angle.

Switch No.	1/ Divisions	Step angle(° )	
		0.72° motor	
0	1/1	0.72	(Factory Setting)
1	1/2	0.36	
2	1/4	0.18	
3	1/10	0.072	
4	1/20	0.036	
5	1/40	0.018	
6	1/100	0.0072	
7	1/200	0.0036	
8	1/400	0.0018	
9	1/800	0.0009	
A	–	–	
B	–	–	
C	1/8	0.09	
D	1/16	0.045	
E	1/80	0.009	
F	1/160	0.0045	

● Driving with two types of step angles are provided by combining the STEP SEL switch setting and the C.S signal.

## 4 – 2. Setting HOLD CURRENT SELECT switch

**CAUTION**

A high setting value may cause burn on the skin due to overheating of the motor.  
Do not select a high value beyond the required.

HOLD CURRENT is set up with the [HOLD] switch.

- (1) Set the [HOLD] switch No. to the ratio of HOLD CURRENT to DRIVE CURRENT required.

● Ratio of HOLD CURRENT

$$\text{Ratio of HOLD CURRENT (\%)} = \frac{\text{HOLD CURRENT}}{\text{DRIVE CURRENT}} \times 100$$

Switch No.	Ratio of HOLD CURRENT (%)
0	10
1	15
2	20
3	25
4	30
5	35
6	40
7	45
8	50
9	55
A	60
B	65
C	70
D	80
E	90
F	100

(Factory Setting)

- HOLD CURRENT changes relative to DRIVE CURRENT setting.  
The ratio of HOLD CURRENT set the switch No. to [No.F]:100% represents the same as the setting for DRIVE CURRENT.
- The greater the ratio of HOLD CURRENT grows, the more heat the motor generates when is on holding-state.



## 4 – 3. Setting DRIVE CURRENT SELECT switch

**CAUTION**

Erroneous setting may cause burn on the skin due to overheating of the motor. Ensure correct setting.

DRIVE CURRENT is set up with the [DRIVE] switch.

- (1) Set the [DRIVE] switch No. to the setting specified in the table '10-5. Applicable Motors'.

● Relationship between the [DRIVE] switch and DRIVE CURRENT.

DRIVE Switch No.	DRIVE CURRENT (A/phase)
0	0.35
1	0.45
2	0.55
3	0.65
4	0.75
5	0.9
6	1.0
7	1.1
8	1.2
9	1.3
A	1.35
B	1.4
C	1.5
D	1.6
E	1.7
F	1.8

(Factory Setting)

#### 4 – 4. Setting HOLD SWITCHING TIME SELECT switch

DRIVE/HOLD CURRENT automatic switching time is set up with the [DHT] switch.

(1) Set the [DHT] switch.

DHT	Hold Switching Time
ON	1s
OFF	150ms

(Factory Setting)

#### 4 – 5. Setting ROTATE CHARACTERISTIC SELECT switch

Please use it with OFF.

## 4 – 6. Setting PULSE INPUT TYPE SELECT switch

**⚠ CAUTION**

Erroneous setting may cause breakage of the machine or injury due to unexpected rotation of motor.  
Ensure correct setting.

2-pulse input method / 1-pulse input method are set up by the [SPI] switch.  
The new setting of the function setting switch will become effective after the power is cycled.

(1) Set the [SPI] switch.

SPI	Input type
ON	1PULSE (1P)
OFF	2PULSE (2P) (Factory Setting)

- When the motor is operated with two pulse signal inputs of CW and CCW, set the SPI switch to [OFF].
- When the motor is operated with the pulse signal and direction signal input, set the SPI switch to [ON].
- In the case that 1-pulse input method is selected, the CCW terminal becomes direction signal input designating the direction of the motor rotation. Drive pulse set to the CW terminal (CW+, CW-).

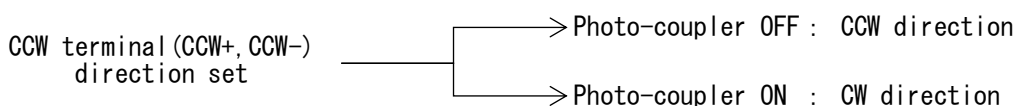

- The input timing is same with 2-pulse input method and 1-pulse input method . As for input timing, refer to "10-3. (2) Drive pulse input (CW, CCW)"

## 4 – 7. Setting MOTOR SELECT switch

**⚠ CAUTION**

Erroneous setting may cause burn on the skin due to overheating of the motor.  
Ensure correct setting.

The OP1 and OP2 switches is turned to the setting corresponding to the motor in use.

(1) Set the OP1 and OP2 switches to the specified in the talbe '10-5. Applicable Motors'.

## 5. Installation

### 5-1. Conditions for Installation

**⚠ WARNING**

Mount it on a noncombustible member.  
Keep it away from combustibles.  
Overheating may cause fire.

- (1) Designed for incorporating into equipment used indoors, this product requires to be installed in the following environment:
- Area that is free of explosive, corrosive or inflammable gas
  - Indoors (Area not exposed to direct sunshine)
  - Area that ambient temperature and humidity are controlled within the range set out in the specifications
  - Area protected from dust, salt or iron particles
  - Area not subject to direct vibration or shock
  - Area not subject to splashing water, oil or chemicals
- (2) Install the driver at least 10mm away from other equipment. However, please be installed to a distance of at least 15mm from the heating element.

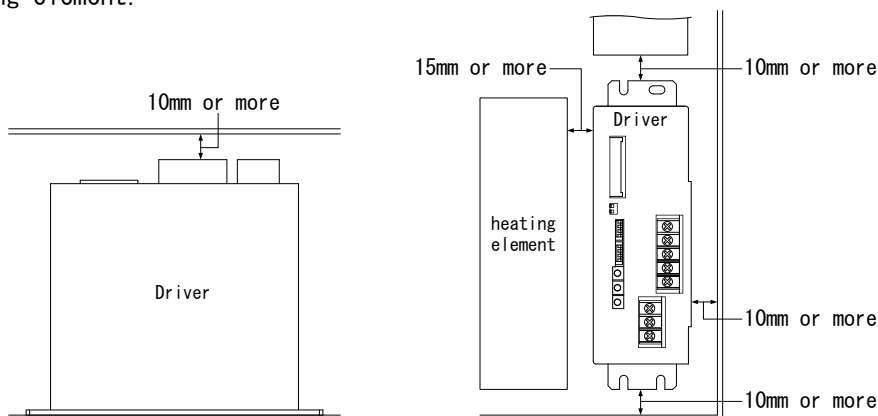

- Please contact us if you are not installed to a distance of at least 15mm from the heating element.
- (3) Considering heat release, control the ambient temperature around the driver within the specified value.
- Take measures against accumulation of heat such as allowing generous space around the driver or installing a fan so that heat release is taken care of.
  - Install the driver securely in contact with metal or other substance with adequate heat conductivity.
- (4) In the case that an overheat alarm signal is output, perform the cooling measure of the mounting plate is enlarged or compulsion air cooling etc.  
Use the driver on the condition that an overheat alarm signal is not output.
- (5) Do not allow standing or placing anything heavy on the product.

## 5 – 2. Mounting Method

The following items are required:

- M-4 screw (8mm or more in length):----- 4
- M-4 spring washer: ----- 4
- M-4 flat washer: ----- 4

- (1) Temporarily fix the product at the round hole.
- (2) Fix the product at the three cutouts.
- (3) Fasten the screw in the round hole.

### ● Mounting example

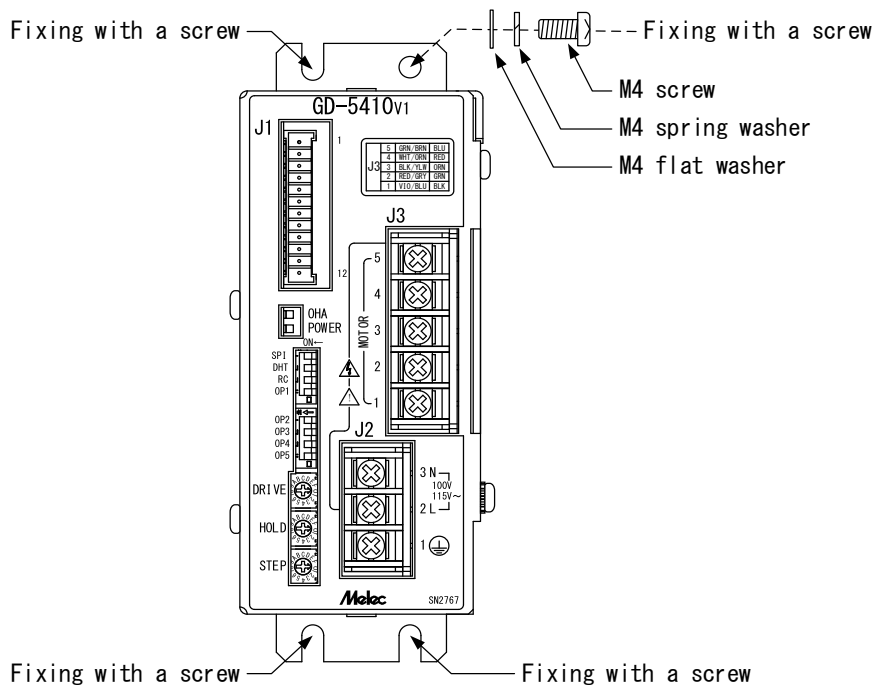

## 6. Connection

### 6-1. Overview of Connection Configuration

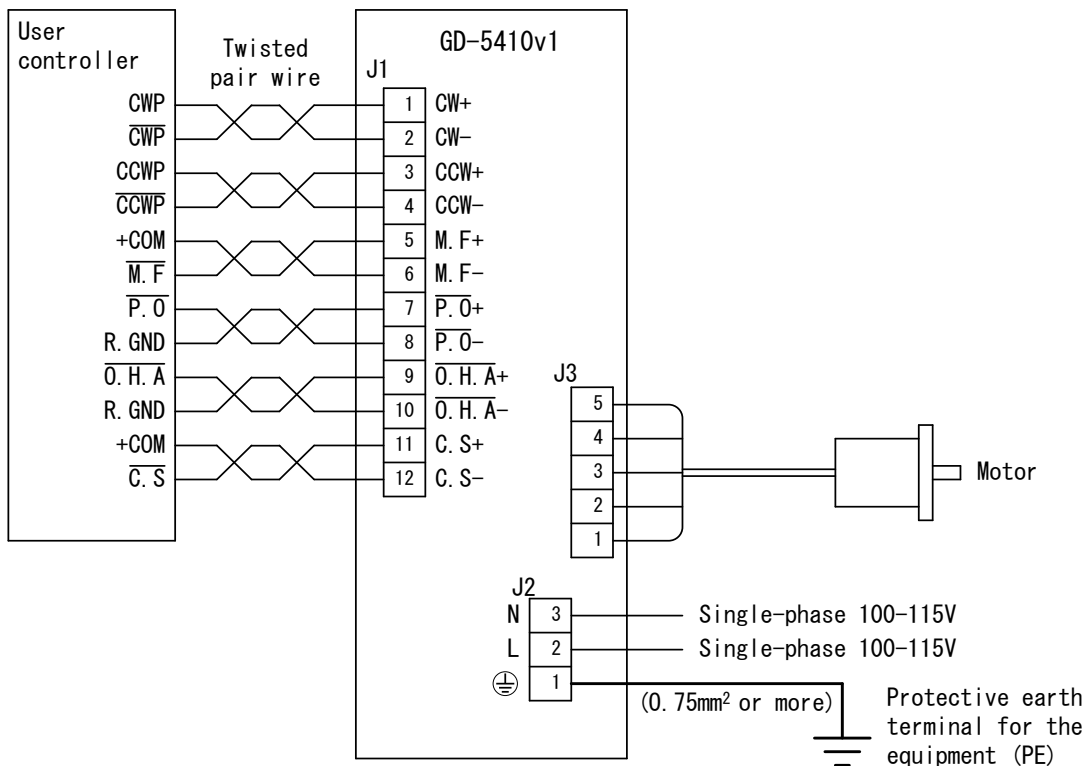

- Connect only one motor to one driver.
- Use twisted pair wire for the CW/CCW input signal line.
- Provide shielding for the signal line where considerable noise is generated.
- Use the wire material of the characteristic that is difficult to burn.
- Provide ferrite core for the motor line if it generates significant noise.

[Example configuration]

The metallic enclosure and shielded wires and ferrite core work to shield noise.

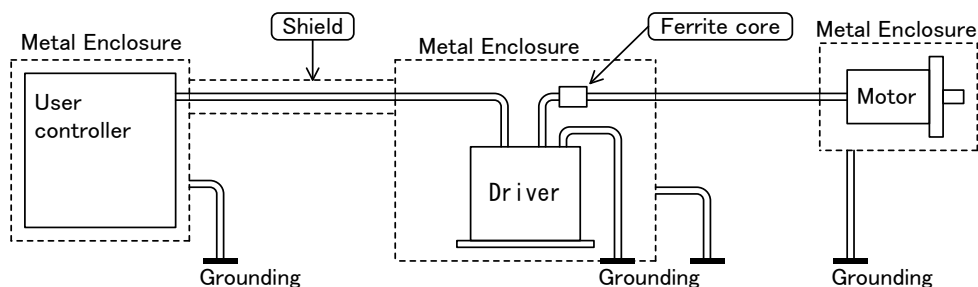

## 6 – 2. Connecting Signal I/O Connector ( J 1 )

The following items are required:

- Housing for J1 (51103–1200:MoLEX): One unit (accessory)
- Contact for J1 (50351–8100:MoLEX): 12 contacts (accessories)
- Manually operated crimping tool for AWG28–22(57295–5000:MoLEX): One unit

- (1) Crimp the contact to the cable used for wiring.
- (2) Insert the contact into the housing.  
Make sure that the housing No. and the connector No. on the main frame are matched before inserting the contacts.
- (3) Connect the housing to the connector on the main frame.
  - The contacts for J1 are 12 pieces.
  - When inserting, keep pushing J1 housing into the connector until it is locked. Also, check if the contacts are not displaced from the housing.
  - In wiring, isolate the J1 signal lines from equipment that may be a source of noise, the power line and the motor line.

(Surface on which the contacts are inserted)

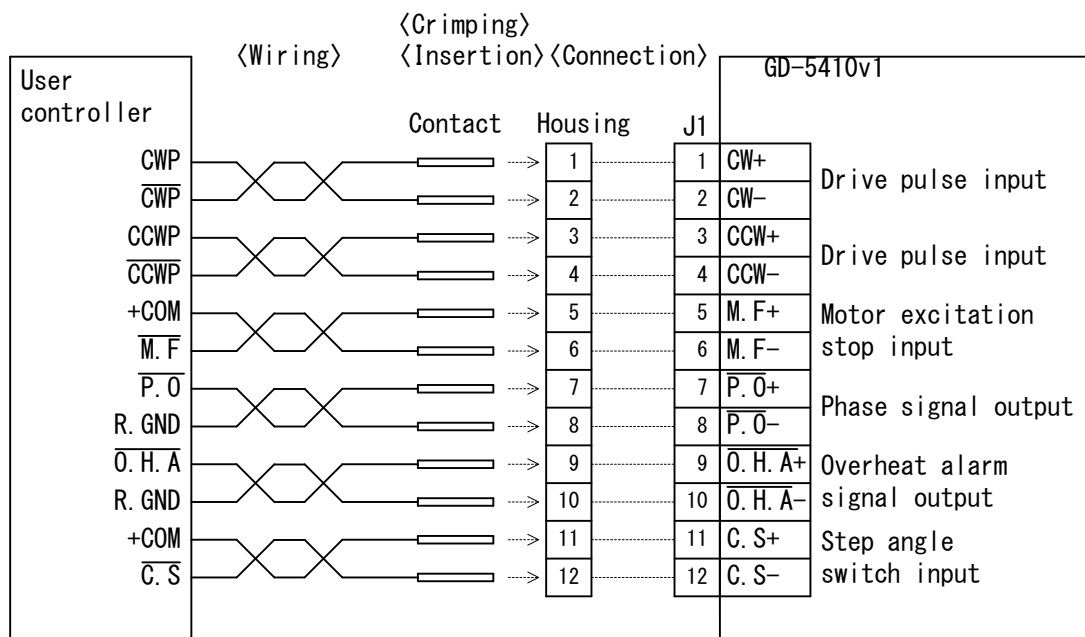
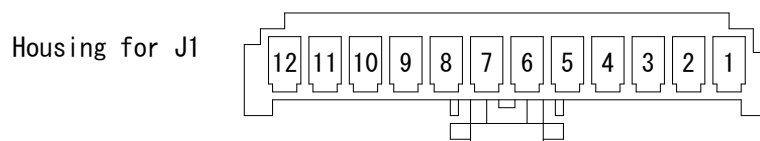

- Use a signal cable of AWG26 (0.15mm<sup>2</sup>) or more in diameter.

## 6 – 3. Connecting AC Input/Motor Output Terminal Block (J 2, J 3)

**⚠ WARNING**

Turn the main power OFF.  
Failure to do so may cause electric shock.

**⚠ WARNING**

Securely ground the protective earth terminal  $\oplus$ .  
Failure to do so may cause electric shock.

**⚠ WARNING**

Do not force the power line or the motor line to be bent or pulled or pinched.  
Doing so may cause electric shock or fire.

**⚠ CAUTION**

Erroneous connection may result in breakage of the motor or the driver.  
Correctly connect the motor wiring.

The following items are required:

- Crimping terminal ----- 8 \*1  
(TMEV1.25-3: Nichifu or the equivalent)
- Manually operated crimping tool for AWG22-16 ----- One unit  
(NH-11: Nichifu or the equivalent)

- (1) Turn power of the equipment [OFF].
- (2) Crimp the crimping terminals to the cable used for wiring.
- (3) Remove the covers of terminal block, then connect.
- (4) Fix the terminal block covers after completing connection.



[Protective earth terminal · AC input terminal]

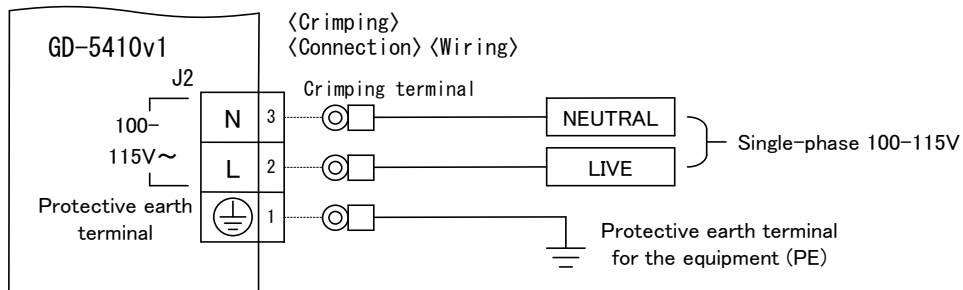

- Be sure to ground the protective earth terminal (⊕) of the driver to the protective earth terminal of the equipment (PE).
- Use a protective earth cable and power cable of AWG18(0.75mm<sup>2</sup>) or more in diameter. \*1

\*1 Warning for UL standards

· UL standards: Use a protective earth cable of AWG14(2mm<sup>2</sup>) or more in diameter.

- Crimping terminal (TMEV2-3S: Nichifu or the equivalent) 1
- Manually operated crimping tool (NH-12: Nichifu or the equivalent) One unit

[Motor output terminal]

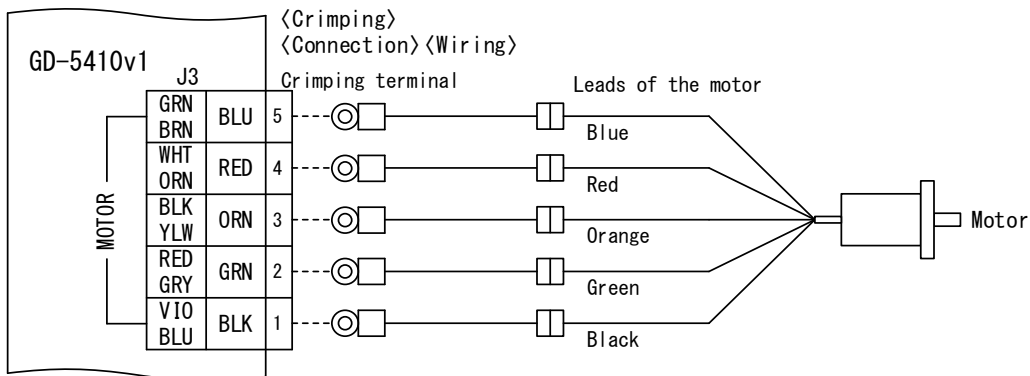
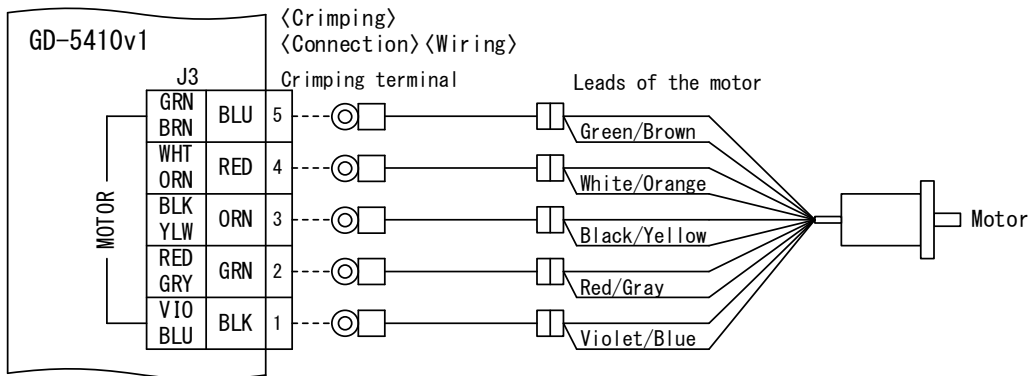



- Color indications for the motor crimping terminals (1~5) represent colors of the leads of the motor.
- Use a motor cable of AWG20 (0.5mm<sup>2</sup>) or more diameter.
- When use a motor cable more than 5m, contact our office.

## 6 – 4. Inputting Power

** WARNING**

Do not contact with a wet hand.  
Doing so may cause electric shock.

** WARNING**

The marks,  and , on the front panel indicate terminals on which power voltage is applied.  
Do not touch such terminals while inputting power and while POWER LED is on.  
Doing so may cause electric shock.

** CAUTION**

Unexpected behavior of the motor may cause breakage of the machine or injury.  
Maintain the state where emergency stop is enabled at any time.

- (1) Input power (single-phase 100–115V) into the cable connected to No.2 and No.3 terminals of J2.

## 7. Confirmation of Setting and Connection

### 7-1. Check Points

- (1) This product requires different switch setting and motor wiring depending on the motor used.  
 Check if the switch setting and the motor wiring are correctly performed.
- (2) Check if the protective earth terminal (⊕) of J2 is securely wired.
- (3) Check if the terminal block covers are fixed on J2 and J3.

Check Points		Check	Remarks
Setting of PULSE INPUT TYPE SELECT switch	OFF/ON		
Setting of HOLD SWITCHING TIME SELECT switch	OFF/ON		
Setting of ROTATE CHARACTERISTIC SELECT switch	OFF/ON		
Setting of MOTOR SELECT switch	OFF/ON		
Setting of Extend functions switch	OFF/ON		
Setting of DRIVE CURRENT SELECT switch	Switch No.		
Setting of HOLD CURRENT SELECT switch	Switch No.		
Setting of STEP ANGLE SELECT switch	Switch No.		
Connection of J1			
Connection of J2	Protective earth terminal (⊕)		
	AC input terminal (L, N)		
	Terminal block cover		
Connection of J3	Motor output terminal		
	Terminal block cover		

## 8. Maintenance and Check-up

### 8 – 1. Maintenance and Check-up



 **WARNING**

Only qualified personnel are allowed to perform maintenance and checking.  
Failure to do so may cause electric shock.

 **WARNING**

Do not contact with a wet hand.  
Doing so may cause electric shock.

 **WARNING**

The marks,  and , on the front panel indicate terminals on which power voltage is applied.  
Do not touch such terminals while inputting power and while POWER LED is on.  
Doing so may cause electric shock.

 **WARNING**

Do not replace fuse.  
Do not disassemble, repair or modify.  
Doing so may cause electric shock, injury or fire.

- (1) As for a maintenance inspection the engineer of the specialty shall do it.
- (2) We recommend that the following check-ups should be performed periodically:
  - Checking for any loosened screws on the terminal block and contacts on the connectors.
  - Checking for any flaw and crack on the cabling.
- (3) In case of failure, return the driver to us and have it repaired.

## 8 – 2. Troubleshooting

Trouble	Check Item	Assumed Cause
1. POWER LED does not come on.	<ul style="list-style-type: none"> <li>• Connection of power supply.</li> <li>• Value of power voltage.</li> </ul>	<ul style="list-style-type: none"> <li>• Wiring error with power supply.</li> <li>• Power voltage failure.</li> <li>• Driver failure.</li> </ul>
2. The motor is not excited. (It can be easily rotated by hand.)	<ul style="list-style-type: none"> <li>• Connection of the motor to the driver.</li> <li>• ON/OFF status of the M.F signal.</li> </ul>	<ul style="list-style-type: none"> <li>• Wiring error with the motor and the driver.</li> <li>• The M.F signal is input.</li> <li>• Driver failure.</li> </ul>
3. The motor does not rotate. The motor behaves abnormally. The motor steps out.	<ul style="list-style-type: none"> <li>• The same check items as those under item 2 above.</li> <li>• Setting of the PULSE INPUT TYPE SELECT switch.</li> <li>• Connection of the pulse signal.</li> <li>• Voltage and wave form of the pulse signal.</li> <li>• Setting of the DRIVE CURRENT SELECT switch.</li> <li>• Setting of the STEP ANGLE SELECT switch.</li> <li>• ON/OFF status of the C.S signal.</li> <li>• Setting of the MOTOR SELECT switch.</li> <li>• Setting of the Extend functions switch.</li> </ul>	<ul style="list-style-type: none"> <li>• Wrong setting for the pulse input type.</li> <li>• Wiring error with the pulse signal line.</li> <li>• Pulse signal of wrong specifications.</li> <li>• DRIVE CURRENT is too low.</li> <li>• Wrong setting for the step angle.</li> <li>• The C.S signal is input.</li> <li>• Wrong setting for the motor selection.</li> <li>• Driver failure.</li> <li>• Motor failure.</li> </ul>
4. The motor steps out during acceleration.	<ul style="list-style-type: none"> <li>• Starting pulse speed.</li> <li>• Acceleration time.</li> </ul>	<ul style="list-style-type: none"> <li>• Starting pulse signal speed is too high.</li> <li>• Acceleration time is too short.</li> </ul>
5. The motor generates excessive heat.	<ul style="list-style-type: none"> <li>• Setting of the DRIVE CURRENT SELECT switch.</li> <li>• Setting of the HOLD CURRENT SELECT switch.</li> <li>• Setting of the MOTOR SELECT switch.</li> </ul>	<ul style="list-style-type: none"> <li>• DRIVE CURRENT is higher than the setting for the applicable motor.</li> <li>• The setting for HOLD CURRENT is too high.</li> <li>• Wrong setting for the motor selection.</li> </ul>
6. Overheat alarm signal is output.	<ul style="list-style-type: none"> <li>• Ambient temperature around the driver.</li> </ul>	<ul style="list-style-type: none"> <li>• Ambient temperature is too high (50°C or more).</li> </ul>

Short-circuiting of the motor output terminal may cause the driver to fail.

- Short-circuiting between the motor output terminal and the earth terminal (PE)
- Short-circuiting between the motor output terminal and the power line
- Short-circuiting between the motor output terminal and the motor output terminal
- Wiring error or snapping of the motor output lines

When the failure phenomenon cannot be remedied, contact our office.

## 9. Storing and Disposal

### 9 – 1. Storing

(1) Keep the product in the following environment:

- Area that is free of explosive, corrosive or inflammable gas
- Indoors (Area not exposed to direct sunshine)
- Area that ambient temperature and humidity are controlled within the range set out in the specifications
- Area protected from dust, salt or iron particles
- Area not subject to direct vibration or shock
- Area not subject to splashing water, oil or chemicals

(2) Do not allow standing or placing anything heavy on the product.

### 9 – 2. Disposal

(1) Dispose of the product as industrial waste.

## 1 0. Specifications

### 1 0 – 1. General Specifications

Supply Power	Single-phase 100–115V (50/60Hz) *1	
	●Rated power at DRIVE:	[DRIVE I. SEL ⇒ No. F set up] *2 AC100V : 2.6A                      AC115V : 2.6A
	●Rated power at HOLD:	[DRIVE I. SEL ⇒ No. F, HOLD I. SEL ⇒ 40% set up] AC100V : 0.3A or less      AC115V : 0.3A or less
Motor output current	●DRIVE CURRENT	0.35A/phase~1.8A/phase (16 levels)
	●HOLD CURRENT	10%~100% of DRIVE CURRENT (16 levels)
Input Signal	●Drive pulse input	(CW, CCW) ----- Photo-coupler input
	●Motor excitation stop input	(M. F) ----- Photo-coupler input
	●Step angle switch input	(C. S) ----- Photo-coupler input
Output Signal	●Phase signal output	(P. O) ----- O/C output
	●Overheat alarm signal output	(O. H. A) ----- O/C output
Function of Operating Sections	●DRIVE CURRENT selection (DRIVE)	●PULSE INPUT TYPE selection (SPI)
	●HOLD CURRENT selection (HOLD)	●HOLD SWITCHING TIME selection (DHT)
	●STEP ANGLE selection (STEP)	●ROTATE CHARACTERISTIC selection (RC)
	●MOTOR selection (OP1, OP2)	
Operating Ambient Temperature	0°C ~ +50°C (No freezing allowed)	
Operating Ambient Humidity	80%RH or less (No condensation allowed)	
Storing Temperature	-10°C ~ +60°C (No freezing allowed)	
Storing Humidity	80%RH or less (No condensation allowed)	
Altitude	Up to 1000m above sea level	
Atmosphere	Indoor (Exposure to direct sunshine is not allowed.) Without any explosive, corrosive or inflammable gas, oil mist, or dust	
Withstanding Vibration	No abnormality should be found after a vibration test at 10~55Hz, 0.15mm P-P.	
Insulated Withstanding Voltage	(At ordinary temperature and humidity)	
	AC terminal – signal terminal	1500VAC: for one minute 500VDC: 100MΩ or more
Insulation Resistance	AC terminal – ⊕ terminal	1500VAC: for one minute 500VDC: 100MΩ or more
Exterior Dimensions	<sup>H</sup> 124.5 × <sup>W</sup> 130 × <sup>D</sup> 55.5 (mm) *3	
Weight	0.55 kg	

\*1 Input voltage range is single-phase 100–115V±10%.

\*2 Power demand varies with rotation speed, a load, etc.

\*3 Including screws and terminal blocks.



## 1 0 – 2. Conforming to Europe standards and UL standards

This product conducted the validation test of low voltage directive and EMC directive with TÜV (TÜV Japan) for self-declaration of the CE making.

### (1) Safety standards

EN 61800-5-1  
UL 61800-5-1 \*1

#### ● Low voltage directive

This product is designed for use as a built-in component.

- Install the product within an enclosure in order to avoid contact with the hand.
- Securely ground the protective earth terminals.

#### ● Installation conditions

Protective class: I  
Overvoltage category: II (EN 61800-5-1), III (UL61800-5-1)  
Pollution degree: Class 2  
Protective type: IP10

#### \*1 Warning for UL standards

This product has no provision for motor over temperature protection.  
Motor over temperature protection is required in the end use product.

### (2) EMC standards

EN 61800-3

#### ● EMC directive

This product conducted EMC measurement with the system configuration for EMC.

- EMC characteristic may vary depending on the configuration of the equipment that contains the driver or stepping motor. Be sure to conduct EMC measurement with the product assembled in your equipment.

#### Configuration

The metallic enclosure and shielded wires and ferrite core work to shield noise.

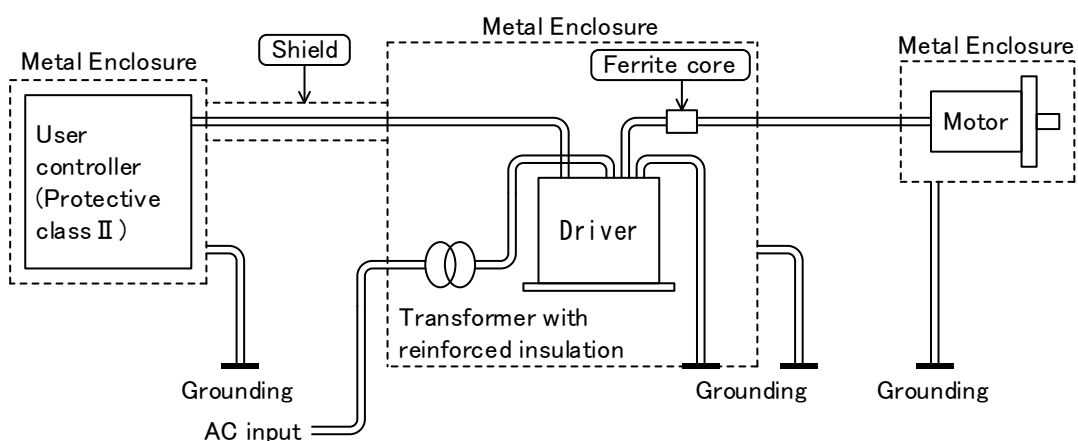

### 1 0 – 3. I/O Signal

#### (1) Example Circuit Connection

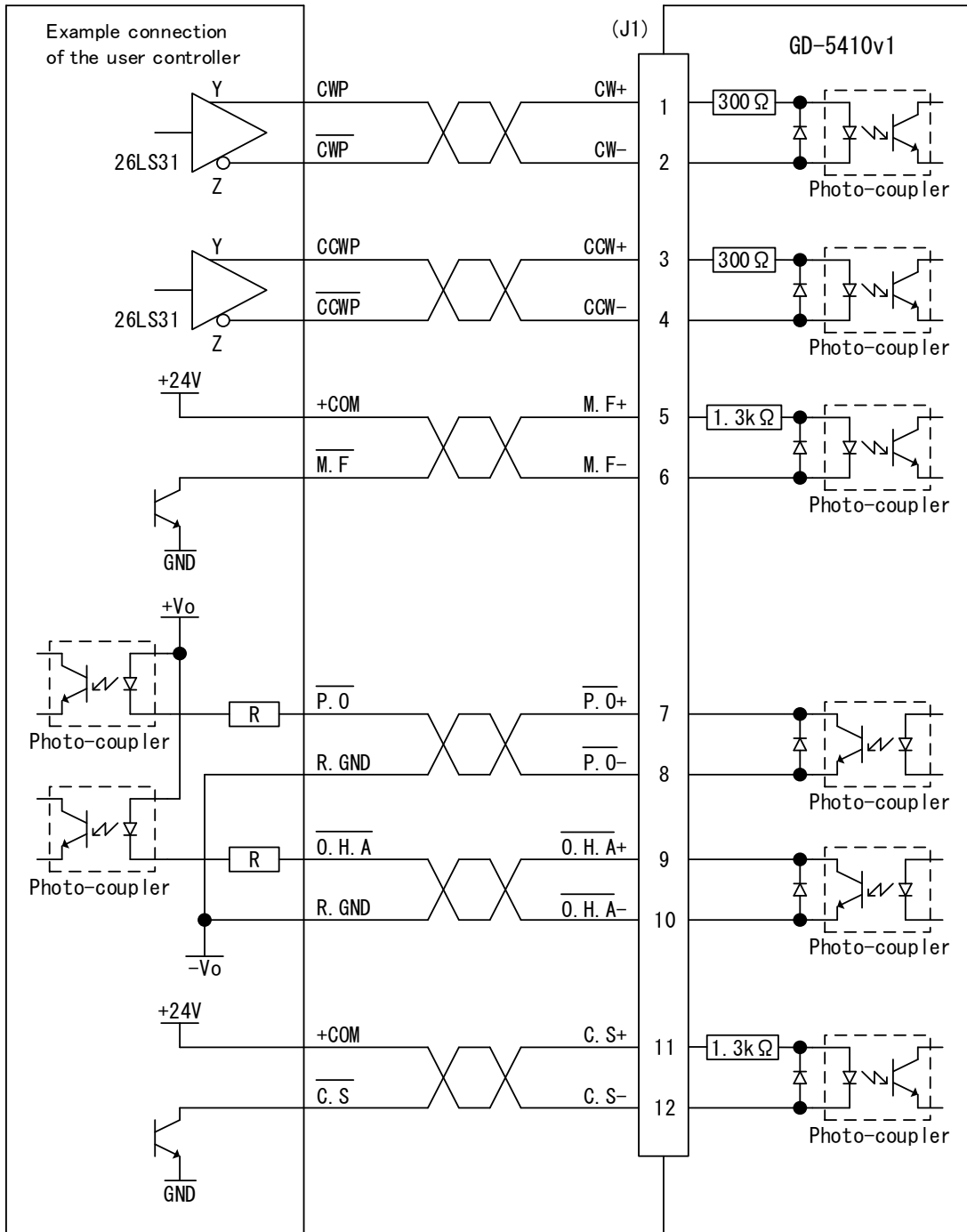

- Power supply for I/O circuit shall be reinforced or double insulation against hazardous voltage such as 100Vac mains. Proving SELV $\leq$ 60Vdc power supply circuit is necessary.

(2) Drive pulse input (CW, CCW)

- ① Operating current range : 9mA~27mA  
The photo-coupler turns on with inter-terminal voltage of 3.1 V~5.5 V. (Photo-coupler diode  $V_F \doteq 1.6$  V)

② Timing chart

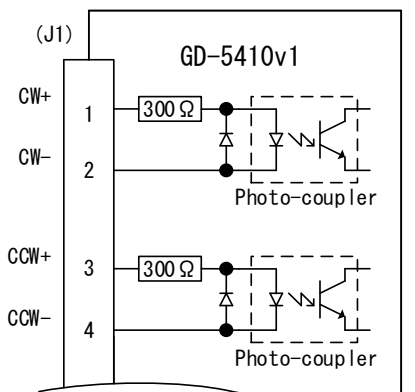
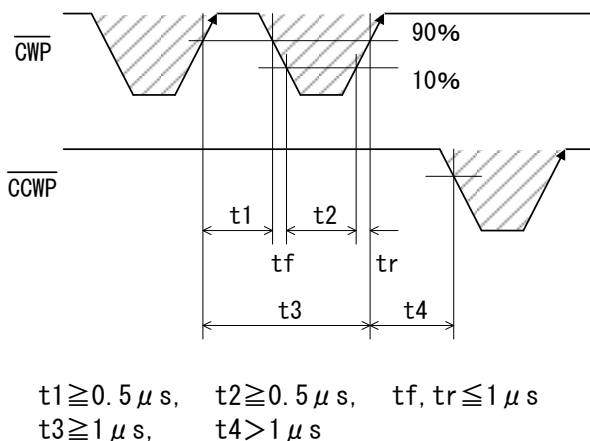

[To the line driver 26LS31]

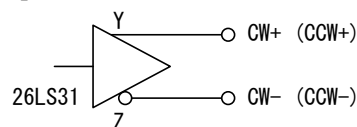

Maximum response frequency : 1MHz  
(Duty 50%)

- The shaded area ( ) indicates light emission from the photo-coupler, and the motor is driven at the rising edge ( ).  
"t4" greatly varies according to the inertial moment including that of the motor.

③ Automatic switching for DRIVE/HOLD

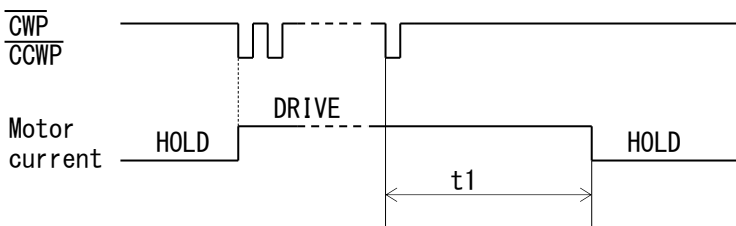

$t1 \doteq 150ms$  (HOLD SWITCHING TIME SELECT switch : OFF)  
 $t1 \doteq 1s$  (HOLD SWITCHING TIME SELECT switch : ON)

- Inputting drive pulse causes the current output to the motor to change from HOLD CURRENT to DRIVE CURRENT, which returns to HOLD CURRENT in "t1".  
DRIVE CURRENT continues if pulse is input on driving-state.

④ Direction of rotation

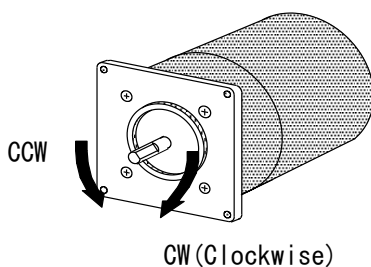

(3) Motor excitation stop input (M.F)

**CAUTION**

Deterioration of the holding power with the motor may cause breakage of the machine or injury.  
 Check safety before inputting.

- ① Operating current range : 2.6mA~19.5mA  
 The photo-coupler turns on with inter-terminal voltage of 4.5V~26.4V.  
 (Photo-coupler diode  $V_F \doteq 1.1\text{ V}$ )

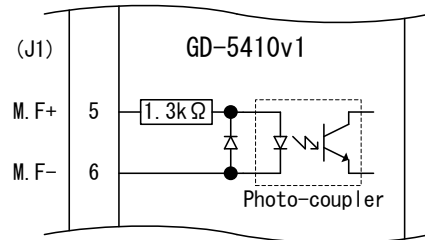

- Motor output current is shut off with the photo-coupler ON.  
 At this time, motor torque changes to detent torque.
- When this signal is input, motor torque may be lost, resulting in failure to retain the load transported.  
 In particular, this risk is high with the vertical drive (such as the Z-axis).

② Timing chart

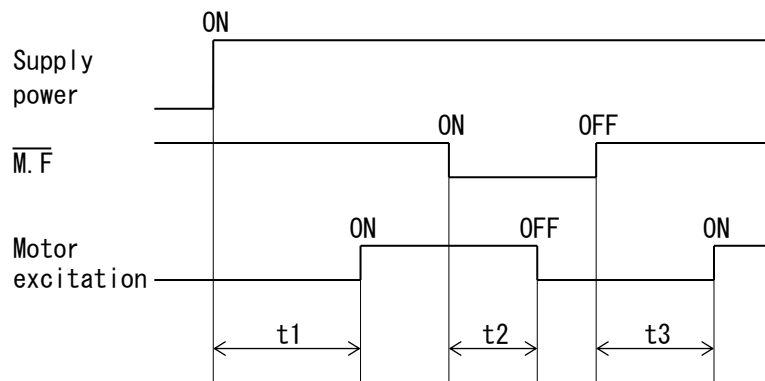

- $t1 \leq 1.5\text{ s}$  ( $t1$  : Time required for the motor to be enabled.)  
 $t2 \leq 20\text{ ms}$  ( $t2$  : Time required for the motor output current to be shut off.)  
 $t3 \leq 100\text{ ms}$  ( $t3$  : Time required for the motor to be enabled.)

(4) Phase signal output (P.0)

- ① Output current
- a.  $I_C \leq 6\text{mA}$ ,  $V_{CE} < 2\text{V}$
  - b.  $I_C \leq 2\text{mA}$ ,  $V_{CE(sat)} < 0.6\text{V}$   
 $V_{CE0} \leq 30\text{V}$

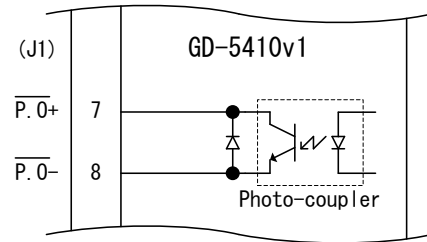

- In case of the excitation home position, the signal is output.  
 (photo-coupler ON)
- In case of simultaneously using P.0 signal and C.S signal,  
 input C.S signal while P.0 signal is being output to switch the step angle.  
 Otherwise, P.0 signal may not be output.

② Timing chart

- P.0 output timing (for 1/1 STEP)

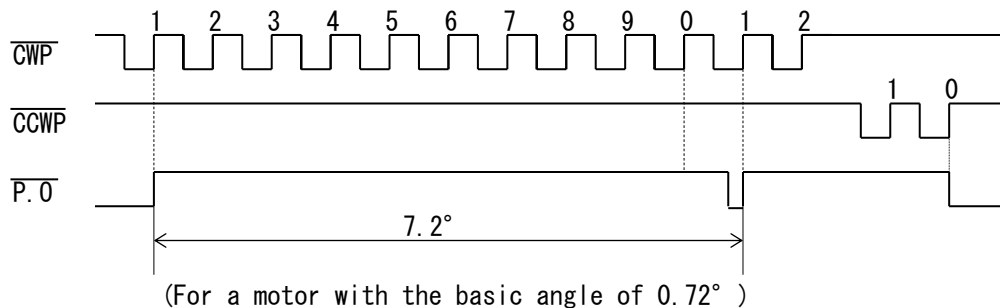

- P.0 output time

1/1 STEP: once in 10 pulses	1/8 STEP: once in 80 pulses
1/2 STEP: once in 20 pulses	1/16 STEP: once in 160 pulses
1/4 STEP: once in 40 pulses	1/80 STEP: once in 800 pulses
1/10 STEP: once in 100 pulses	1/160 STEP: once in 1600 pulses
1/20 STEP: once in 200 pulses	
1/40 STEP: once in 400 pulses	
1/100 STEP: once in 1000 pulses	
1/200 STEP: once in 2000 pulses	
1/400 STEP: once in 4000 pulses	
1/800 STEP: once in 8000 pulses	

(5) Overheat alarm signal output (O. H. A)

**⚠ WARNING**  
 Overheating may cause fire.  
 Stop operation upon output of this signal.

**⚠ WARNING**  
 Overheating may cause fire.  
 Stop operation when this LED comes on.

- ① Output current
- a.  $I_C \leq 6\text{mA}$ ,  $V_{CE} < 2\text{V}$
  - b.  $I_C \leq 2\text{mA}$ ,  $V_{CE(\text{sat})} < 0.6\text{V}$   
 $V_{CE0} \leq 30\text{V}$

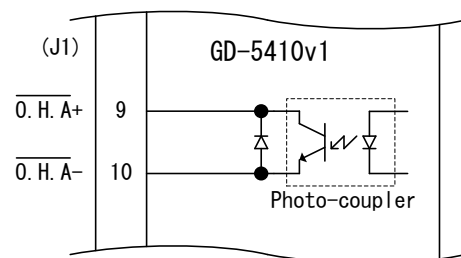

- Use overheat alarm signal output (O. H. A) without fail.
- In case of internal temperature of the driver reaches approx. 80°C or more, this signal is output (photo-coupler ON) and O. H. A LED comes on. At this time the motor output current is not blocked.
- When this signal is output, stop operation and check if there is any abnormality occurring with the motor and the driver.
- Perform the cooling measure of the mounting plate is enlarged or compulsion air cooling, for example, if this signal is output while no abnormality is detected.
- Continuous operation is possible unless this signal is output.

(6) Step angle switch input (C.S)

- ① Operating current range : 2.6mA~19.5mA  
 The photo-coupler turns on with inter-terminal voltage of 4.5V~26.4V.  
 (Photo-coupler diode  $V_F \approx 1.1\text{ V}$ )

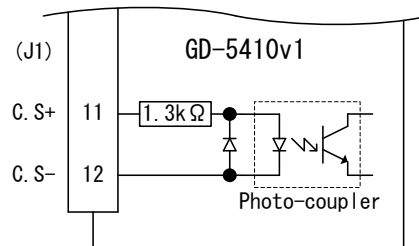

- Step angle division is switched to 1/20 divisions with the photo-coupler ON. The setting for the STEP ANGLE SELECT switch is ignored.
- No displacement occurs even if the step angle is switched by the C.S signal.

② Timing chart

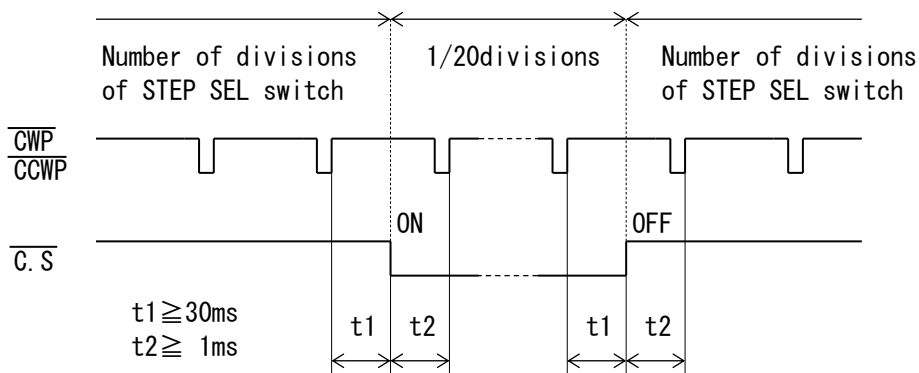

- Switching the step angle by the C.S signal requires time t1 and t2 before and after inputting drive pulse.

③ STEP ANGLE SELECT switch and C.S signal

Switch No.	1/ Divisions	Step angle(° )
		0.72° motor
0	1/1	0.72
1	1/2	0.36
2	1/4	0.18
3	1/10	0.072
4	1/20	0.036
5	1/40	0.018
6	1/100	0.0072
7	1/200	0.0036
8	1/400	0.0018
9	1/800	0.0009
A	-	-
B	-	-
C	1/8	0.09
D	1/16	0.045
E	1/80	0.009
F	1/160	0.0045

[When the C.S signal is input]



1/20 (0.036° )

1 0 - 4. Dimensions

(Unit : mm)

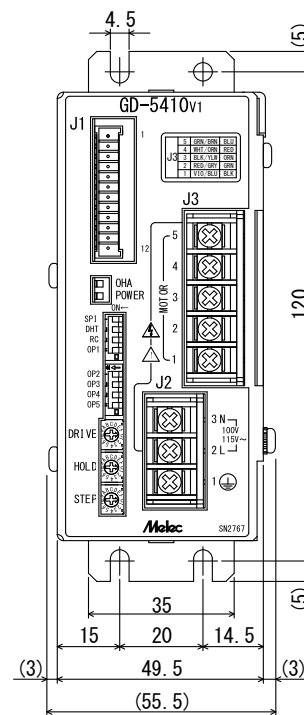
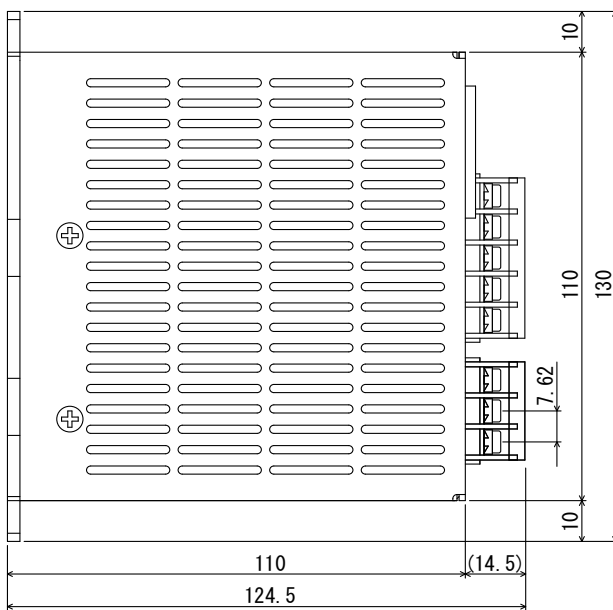
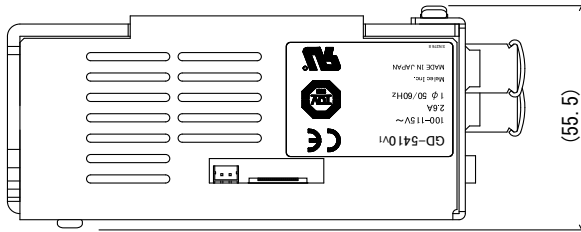



## 10-5. Applicable Motors

●GD-5410v1 can drive a 5-phase stepping motors of 0.75 - 1.8A/phase.

ORIENTAL MOTOR CO., LTD.		Basic Angle (°)	Current (A/phase)	DRIVE switch	OP1 switch	OP2 switch	Torque Data Fig. No.
□42mm	PK543-A (B) PK544-A (B) PK545-A (B)	0.72	0.75	4	ON	ON	Fig. 1 Fig. 2 Fig. 3
□42mm	PKP543N18A (B) 2 PKP544N18A (B) 2 PKP545N18A (B) 2 PKP546N18A (B) 2	0.72	1.8	F	ON	ON	Fig. 4 Fig. 5 Fig. 6 Fig. 7
□60mm	PK564-A (B) PK566-A (B)	0.72	0.75	4	ON	ON	Fig. 8 Fig. 9
□60mm	PK564H-A (B) PK566H-A (B) PK569-A (B)	0.72	1.4	B	ON	ON	Fig. 10 Fig. 11 Fig. 12
□90mm	PK596-A (B) PK599-A (B)	0.72	1.4	B	ON	ON	Fig. 13 Fig. 14

SANYO DENKI CO., LTD.		Basic Angle (°)	Current (A/phase)	DRIVE switch	OP1 switch	OP2 switch	Torque Data Fig. No.
□42mm	103F5505-7241 (7211) 103F5508-7241 (7211) 103F5510-7241 (7211)	0.72	0.75	4	ON	ON	Fig. 15 Fig. 16 Fig. 17
□60mm	103F7852-8241 (8211) 103F7853-8241 (8211)	0.72	1.4	B	ON	ON	Fig. 18 Fig. 19

( ) : Both axis

●When use a non-applicable motor, contact our office.

## 1 0 – 6. Torque Characteristics

- (1) Representations in the torque characteristics table are made in terms of the motor rotation speed ( $s^{-1}$ ) vs. torque ( $N \cdot m$ ).

Motor rotation speed ( $s^{-1}$ ) and drive pulse frequency (Hz) are converted as follows:

$$\text{Motor rotation speed (s}^{-1}\text{)} \times \frac{360^\circ}{\text{Step angle}} = \text{Drive pulse input frequency (Hz)}$$

- Maximum value of the rotation speed is  $100s^{-1}$  at  $0.72^\circ$  motor.
- (2) The Maximum Starting Pulse Rate is represented as "fs" by the value at zero inertial load.
- (3) Upon operation, provide adequate allowance for torque.
- (4) The stepping motor may attain high temperature, depending on the operational conditions.  
Use the stepping motor according to the Instructions Manual produced by motormakers.

**Fig. 1**

GD-5410v1  
PK543-A (B)  
0.75A/PHASE

DRIVE = No. 4  
OP1, OP2 = ON, ON  
AC100V

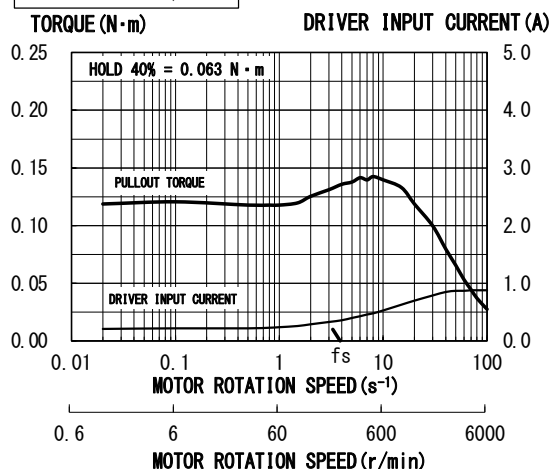

**Fig. 2**

GD-5410v1  
PK544-A (B)  
0.75A/PHASE

DRIVE = No. 4  
OP1, OP2 = ON, ON  
AC100V

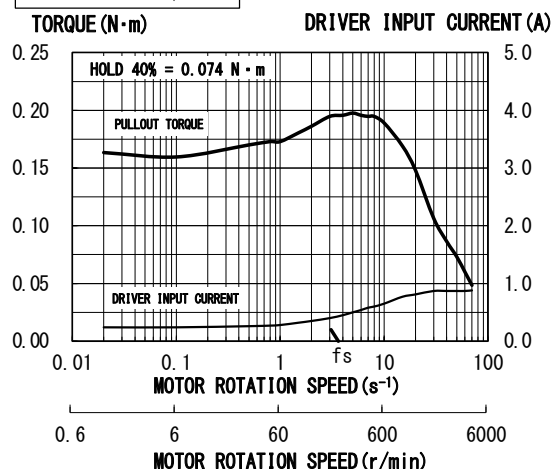

**Fig. 3**

GD-5410v1  
PK545-A (B)  
0.75A/PHASE

DRIVE = No. 4  
OP1, OP2 = ON, ON  
AC100V

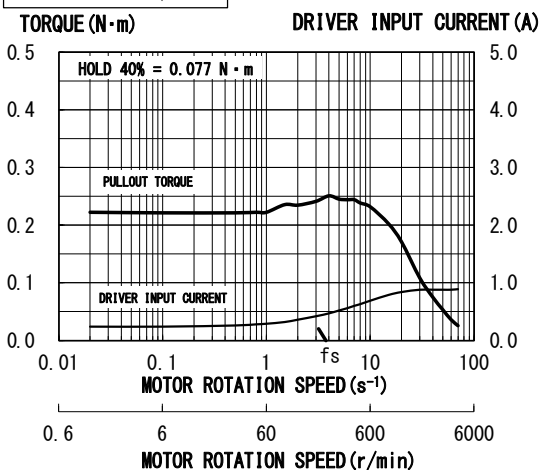

**Fig. 4**

GD-5410v1  
PKP543N18A (B) 2  
1.8A/PHASE

DRIVE = No. F  
OP1, OP2 = ON, ON  
AC100V

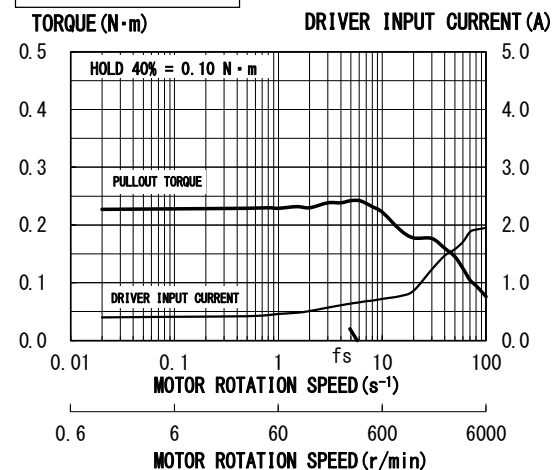

**Fig. 5**

GD-5410v1  
PKP544N18A (B) 2  
1.8A/PHASE

DRIVE = No. F  
OP1, OP2 = ON, ON  
AC100V

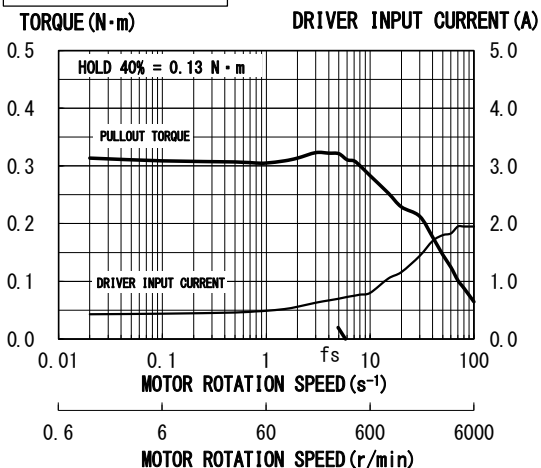

**Fig. 6**

GD-5410v1  
PKP545N18A (B) 2  
1.8A/PHASE

DRIVE = No. F  
OP1, OP2 = ON, ON  
AC100V

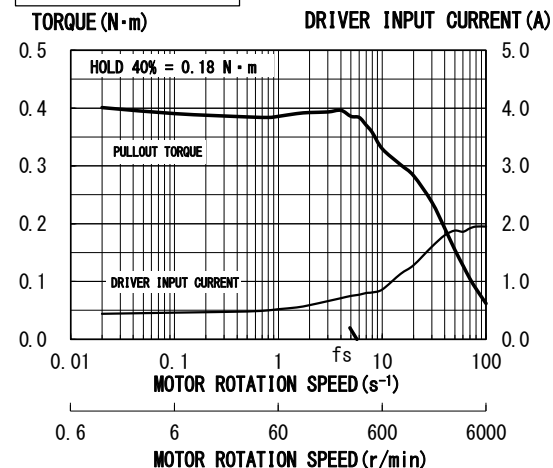

**Fig. 7**

GD-5410v1  
PKP546N18A (B) 2  
1.8A/PHASE

DRIVE = No. F  
OP1, OP2 = ON, ON  
AC100V

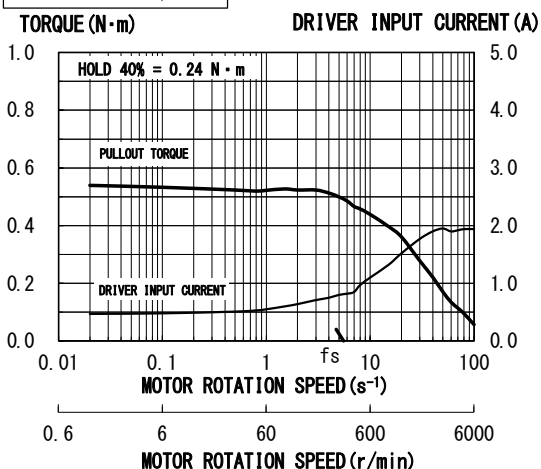

**Fig. 8**

GD-5410v1  
PK564-A (B)  
0.75A/PHASE

DRIVE = No. 4  
OP1, OP2 = ON, ON  
AC100V

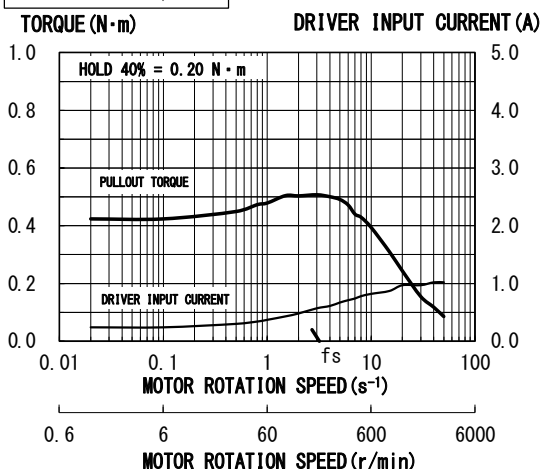

**Fig. 9**

GD-5410v1  
PK566-A (B)  
0.75A/PHASE

DRIVE = No. 4  
OP1, OP2 = ON, ON  
AC100V

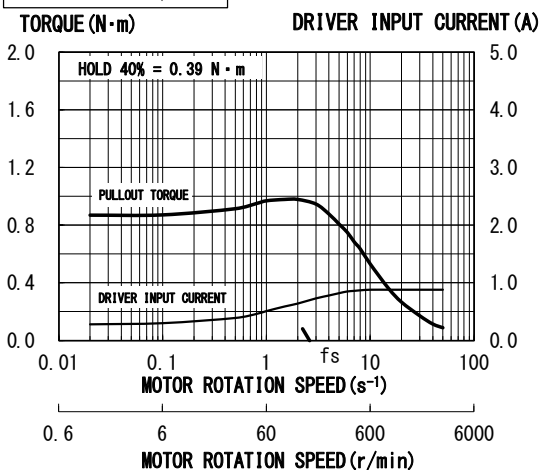

**Fig. 10**

GD-5410v1  
PK564H-A (B)  
1.4A/PHASE

DRIVE = No. B  
OP1, OP2 = ON, ON  
AC100V

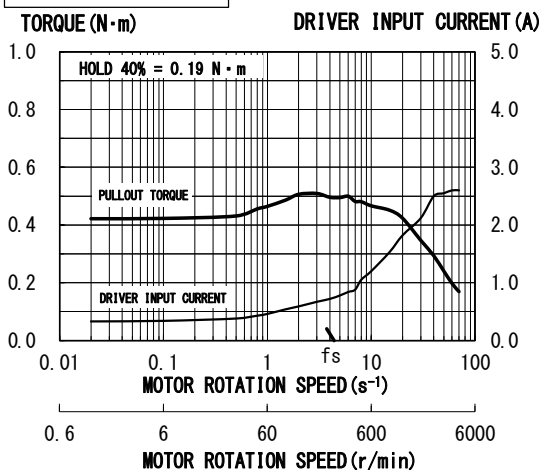

**Fig. 11**

GD-5410v1  
PK566H-A (B)  
1.4A/PHASE

DRIVE = No. B  
OP1, OP2 = ON, ON  
AC100V

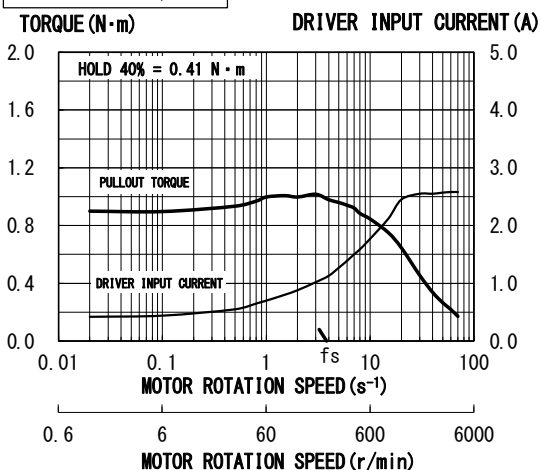

**Fig. 12**

GD-5410v1  
PK569-A (B)  
1.4A/PHASE

DRIVE = No. B  
OP1, OP2 = ON, ON  
AC100V

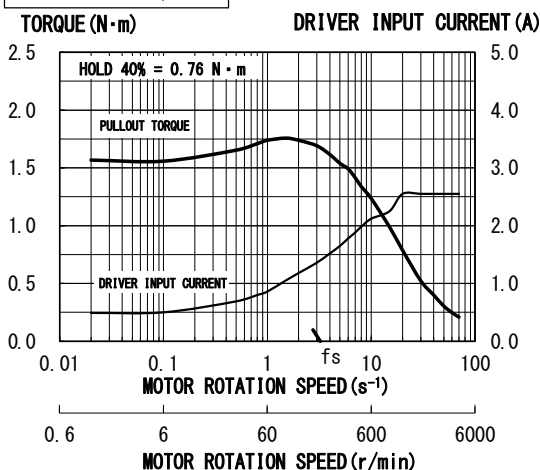

**Fig. 13**

GD-5410v1  
PK596-A (B)  
1.4A/PHASE

DRIVE = No. B  
OP1, OP2 = ON, ON  
AC100V

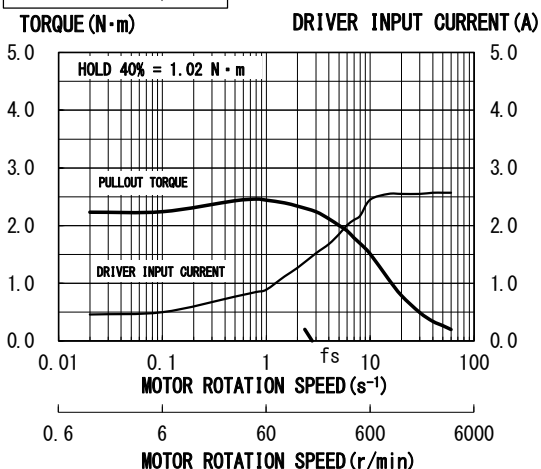

**Fig. 14**

GD-5410v1  
PK599-A (B)  
1.4A/PHASE

DRIVE = No. B  
OP1, OP2 = ON, ON  
AC100V

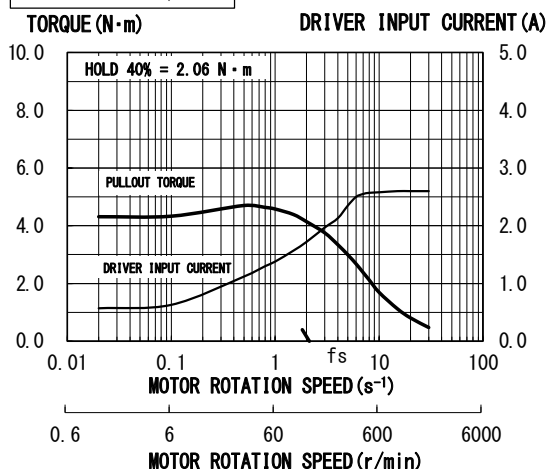

**Fig. 15**

GD-5410v1  
103F5505-7241 (7211)  
0.75A/PHASE

DRIVE = No. 4  
OP1, OP2 = ON, ON  
AC100V

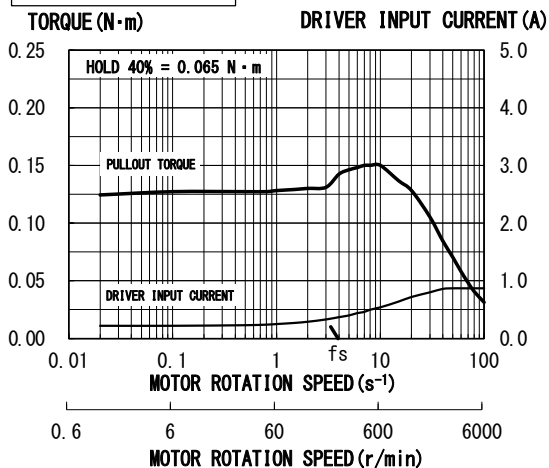

**Fig. 16**

GD-5410v1  
103F5508-7241 (7211)  
0.75A/PHASE

DRIVE = No. 4  
OP1, OP2 = ON, ON  
AC100V

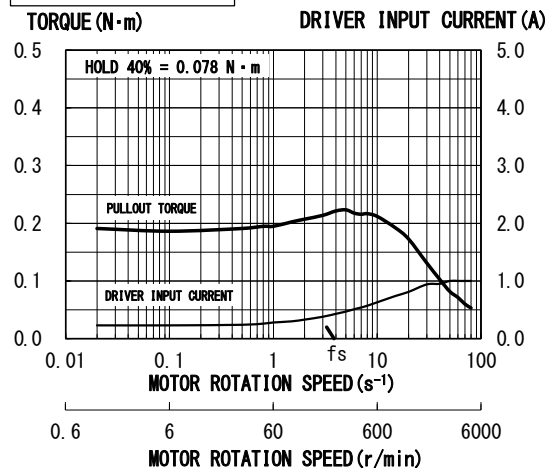

**Fig. 17**

GD-5410v1  
103F5510-7241 (7211)  
0.75A/PHASE

DRIVE = No. 4  
OP1, OP2 = ON, ON  
AC100V

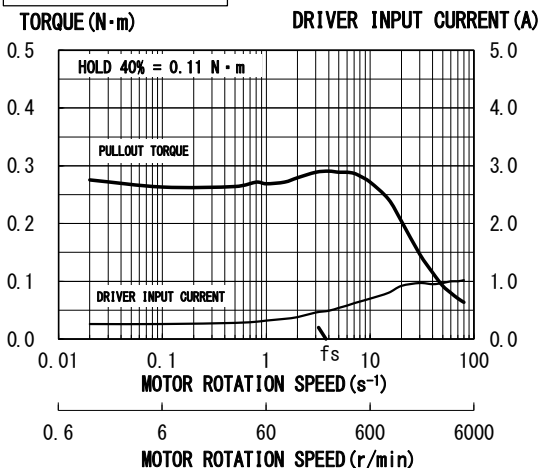

**Fig. 18**

GD-5410v1  
103F7852-8241 (8211)  
1.4A/PHASE

DRIVE = No. B  
OP1, OP2 = ON, ON  
AC100V

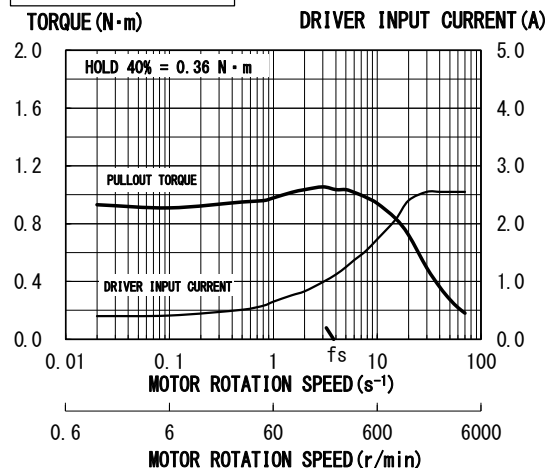

**Fig. 19**

GD-5410v1  
 103F7853-8241 (8211)  
 1.4A/PHASE

DRIVE = No. B  
 OP1, OP2 = ON, ON  
 AC100V

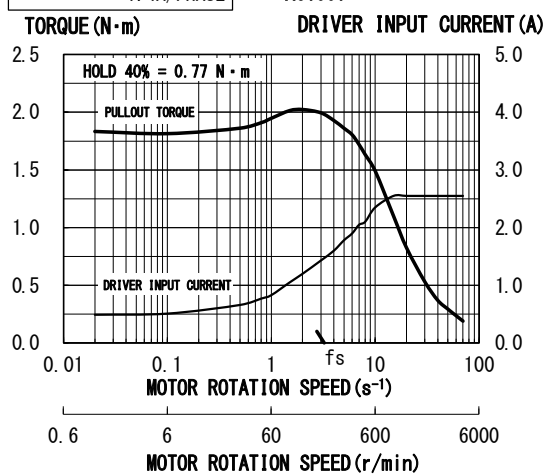

The main parts which revised by this manual

Parts	Content

---

## **Technical Service**

TEL. (042) 664-5382 FAX. (042) 666-5664  
E-mail [s-support@melec-inc.com](mailto:s-support@melec-inc.com)

---

## **Sales and Service**

TEL. (042) 664-5384 FAX. (042) 666-2031  
URL:<http://www.melec-inc.com>

Melec Inc. Control equipment marketing department  
516-10, Higashiasakawa-cho, Hachioji-shi, Tokyo 193-0834, Japan

---

This Operating Manual is subject to change without prior notice  
for the purpose of product improvement.

C1810