

Melec

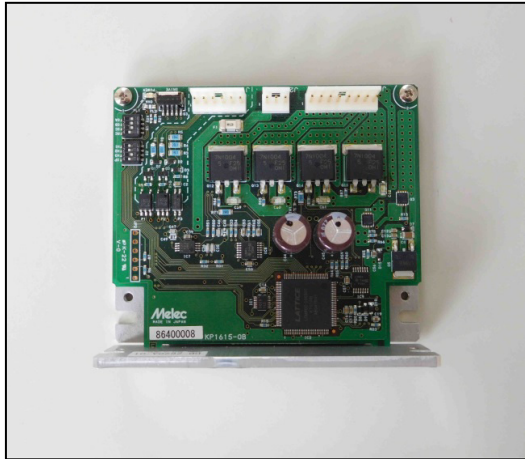

2-phase Stepping Motor Driver

DB-2620Av1

Instructions Manual (For designers' use)

USER'S MANUAL

Please ensure to read and understand this Instructions Manual before using the product. Please keep this Instructions Manual at hand so that it is always available for reference.

CE

MN0331-1

Introduction

This Instructions Manual describes the safe and proper method of handling "2-phase Stepping Motor Driver DB-2620Av1" with emphasis on the specifications, assuming that our readers are engaged in designing of control devices incorporating stepping motors.

Please ensure to read and understand this Instructions Manual before using the product.

Please keep this Instructions Manual at hand so that it is always available for reference.

Descriptions in this manual on safety matters:

This product must be operated and used properly.

Otherwise , or when it is operated and used erroneously, unforeseen accidents may occur, causing physical injuries or property damages.

Majority of these accidents can be avoided if you are well informed of hazardous circumstances in advance.

Consequently, this instructions manual describes all the hazardous and dangerous circumstances and situations which can be foreseen and anticipated as well as necessary precautions.

All the above descriptions are being titled by the following symbol-marks and signal-words, namely:



Represents warnings ignorance of which can cause accidents involving fatal or serious physical injuries.



Represents cautions ignorance of which can cause accidents involving minor physical injuries or property damages.

Introduction

Descriptions in this manual on safety matters:

	CONTENTS	PAGE
1. Safety		
1-1. Safety Precautions		6
1-2. Safety Information for Handling		7
2. Overview		
2-1. Characteristics		9
2-2. Product Configuration		9
2-3. Appearance		9
3. Name and Function of Each Section		
3-1. Signal I/O Connector (J1)		10
3-2. DC Input/Motor Output Connector (J2, J3)		10
3-3. POWER LED		11
3-4. Operating Section		11
4. Function Set-up by Use		
4-1. Setting STEP ANGLE SELECT switch		12
4-2. Setting HOLD CURRENT SELECT switch		13
4-3. Setting DRIVE CURRENT SELECT switch		14
4-4. Setting PULSE INPUT TYPE SELECT switch		15
4-5. Setting ROTATE CHARACTERISTIC SELECT switch		15
5. Installation		
5-1. Conditions for Installation		16
5-2. Mounting Method		17
6. Connection		
6-1. Overview of Connection Configuration		18
6-2. Connecting Signal I/O Connector (J1)		19
6-3. Connecting DC Input/Motor Output Connector (J2, J3)		20
6-4. Inputting Power		21
7. Confirmation of Setting and Connection		
7-1. Check Points		22

	PAGE
8. Maintenance and Check-up	
8-1. Maintenance and Check-up	23
8-2. Troubleshooting	24
9. Storing and Disposal	
9-1. Storing	25
9-2. Disposal	25
10. Specifications	
10-1. General Specifications	26
10-2. I/O Signal	
(1) Example Circuit Connection (J1)	27
(2) Drive pulse input (CW, CCW)	28
(3) Motor excitation stop input (M.F)	29
10-3. Dimensions	30
10-4. Applicable Motors	31
10-5. Torque Characteristics	32
10-6. Conforming to Europe standards	37

The main parts which revised by this manual

1. Safety

1 – 1. Safety Precautions

 WARNING
--

- (1) This product is not designed or manufactured for application for equipment requiring high level of reliability such as equipment related to nuclear energy, aeronautics-related equipment, automobiles, ships, medical appliances directly handling the human body and equipment that might seriously affect properties.
- (2) Do not use or keep the product in explosive or corrosive environments, in the presence of flammable gases, locations subjected to splashing water, fine particles, soot, steam, or exposed to radiation or direct sunshine. Doing so may cause injury or fire.
- (3) For the driver's power supply, use a DC power supply with reinforced insulation on its primary and secondary sides. Failure to do so may cause electric shock.
- (4) This product is designed for use within machinery, so it should be installed within an enclosure. Failure to do so may cause injury.
- (5) Do not transport, move, install the product, perform connections or inspections when the power is on. Doing so may cause electric shock, injury or fire.
- (6) Only qualified personnel are allowed to transport, move, install the product, perform connections or inspections. Failure to do so may cause injury or fire.

 CAUTION
--

- (7) Do not touch the driver during operation or immediately after stopping. Doing so may cause burn on the skin due to overheating of the driver.
- (8) Ensure to use this product according to the method specified in the Instructions Manual and within the specifications.
- (9) Depending on the operational conditions, the stepping motor may step out when it is on holding-state or driving-state. In particular, the load in transport may fall if the motor steps out on the vertical drive (such as the Z-axis). Start operation after test run for deliberate confirmation of operation.
- (10) Provide fail-safe measures so that the entire system may operate in a safe mode even in cases of the external power supply failure, disconnection of the signal line, or any failure on the driver.

1 – 2. Safety Information for Handling

●Overall:

 CAUTION

Do not touch the driver during operation or immediately after stopping.
It may cause burn on the skin due to overheating of the driver.

●When setting up the STEP ANGLE SELECT switch:

 CAUTION

Erroneous setting may cause breakage of the machine or injury due to unexpected rotation of the motor.
Ensure correct setting.

●When setting up the HOLD CURRENT SELECT switch:

 CAUTION

A high setting value may cause burn on the skin due to overheating of the motor.
Do not select a high value beyond the required.

●When setting up the DRIVE CURRENT SELECT switch:

 CAUTION

Erroneous setting may cause motor deterioration or damage and burn on the skin due to overheating of the motor.
Ensure correct setting.

●When setting up the PULSE INPUT TYPE SELECT switch:

 CAUTION

Erroneous setting may cause breakage of the machine or injury due to unexpected rotation of the motor.
Ensure correct setting.

●When installing:

 **WARNING**

Overheating may cause fire.
Mount it on a noncombustible member.
Keep it away from combustibles.

●When connecting the DC Input/Motor Output Connectors (J2, J3):

 **CAUTION**

Erroneous connection may cause
breakage of the motor or the driver.
Correctly connect the DC Input/Motor
output connector.

●When inputting power:

 **CAUTION**

Breakage of the machine or injury is
apprehended due to unexpected behavior of
the motor. Maintain the state where
emergency stop is enabled at any time.

●When inputting the motor excitation stop (M.F) signal:

 **CAUTION**

Deterioration of the holding power with
the motor may cause breakage of the machine
or injury.
Check safety before inputting.

●When performing maintenance and checking:

 **WARNING**

Injury or fire is apprehended due to
unexpected behavior.
Do not replace fuse.
Do not disassemble, repair or modify.

2. Overview

2-1. Characteristics

DB-2620Av1 is a driver for a 2-phase stepping motor with DC+24V input.
 Driving method is unipolar constant current type.
 It can drive a 2-phase stepping motor of unipolar winding ranging from 0.4A/phase to 2.0/phase.
 Step angles can be selected from fourteen step angles ranging from 1 division to 32 division of the basic angle.
 HOLD CURRENT and DRIVE CURRENT can be set up.

2-2. Product Configuration

●DB-2620Av1 One unit(main frame)

J1, J2, J3 of the housing and the contact is not in accessories.

2-3. Appearance

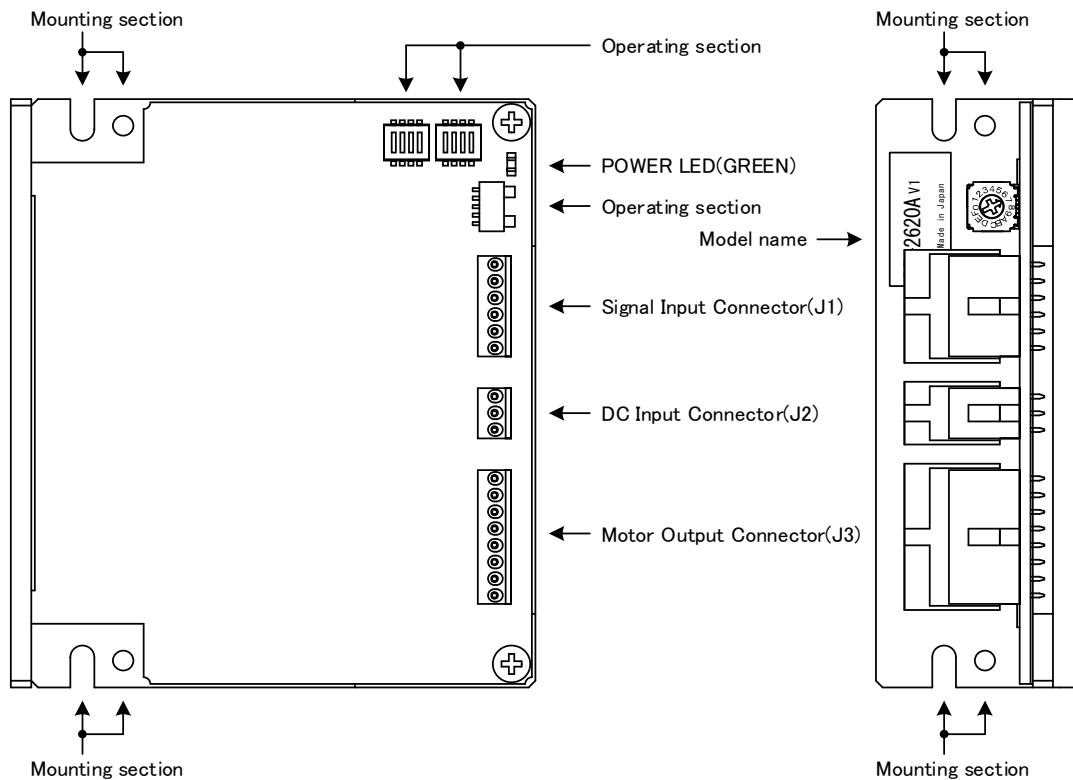

3. Name and Function of Each Section

3 – 1. Signal I/O Connector (J 1)

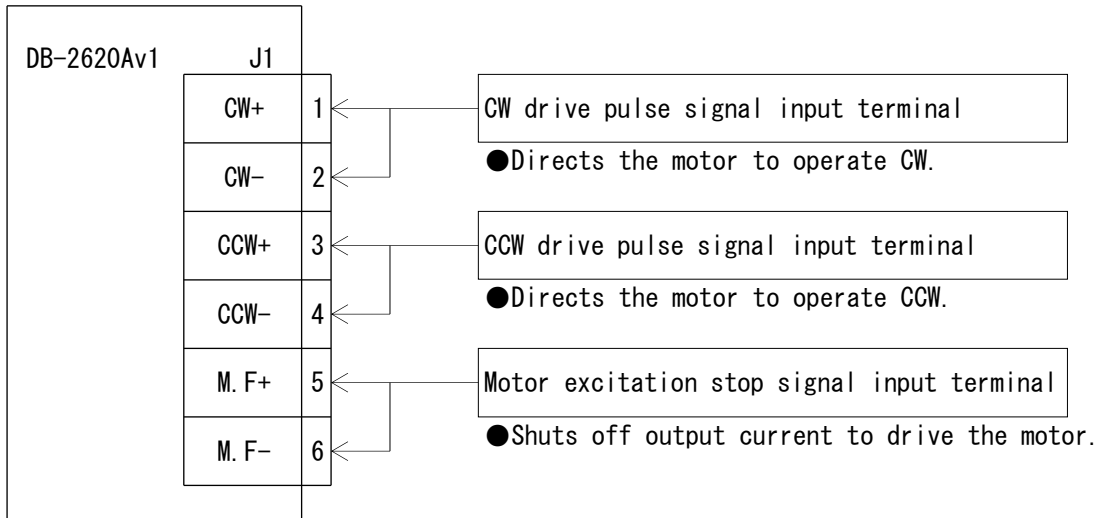

3 – 2. DC Input/Motor Output Connector (J 2 , J 3)

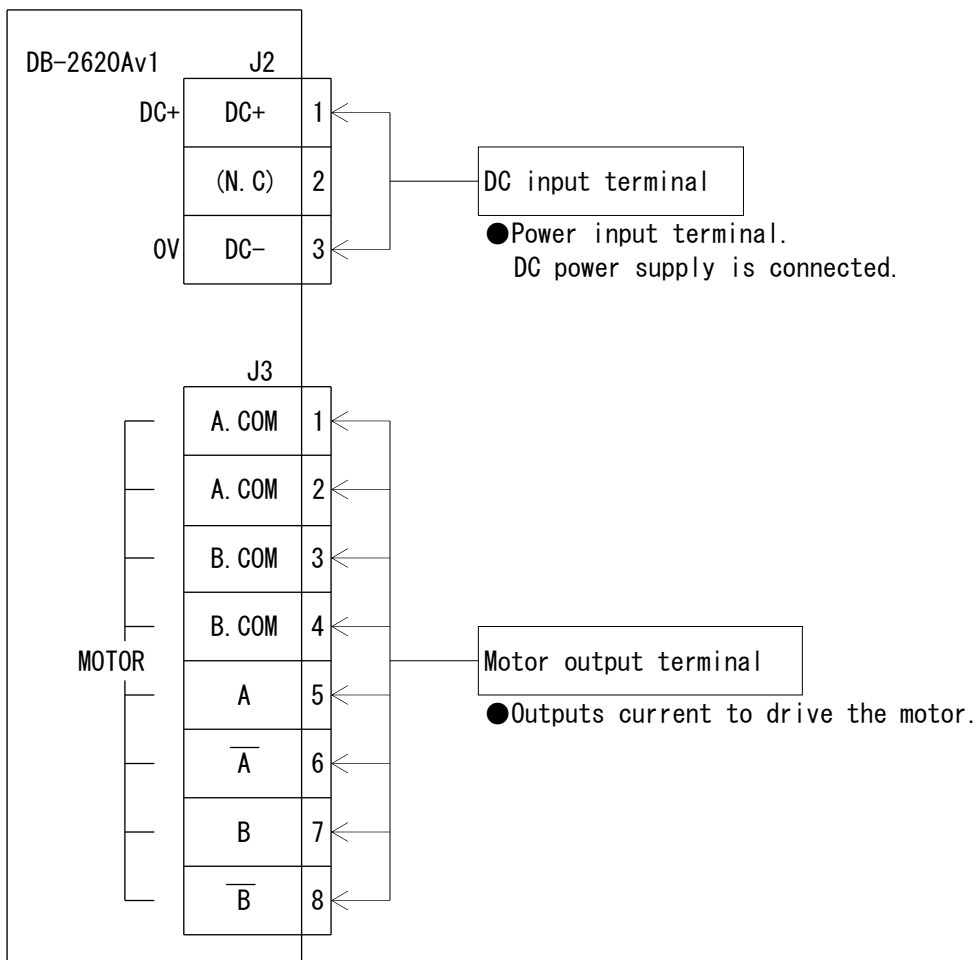

3 – 3. POWER LED

POWER LED (GREEN) comes on upon inputting power.

3 – 4. Operating Section

DB-2620Av1

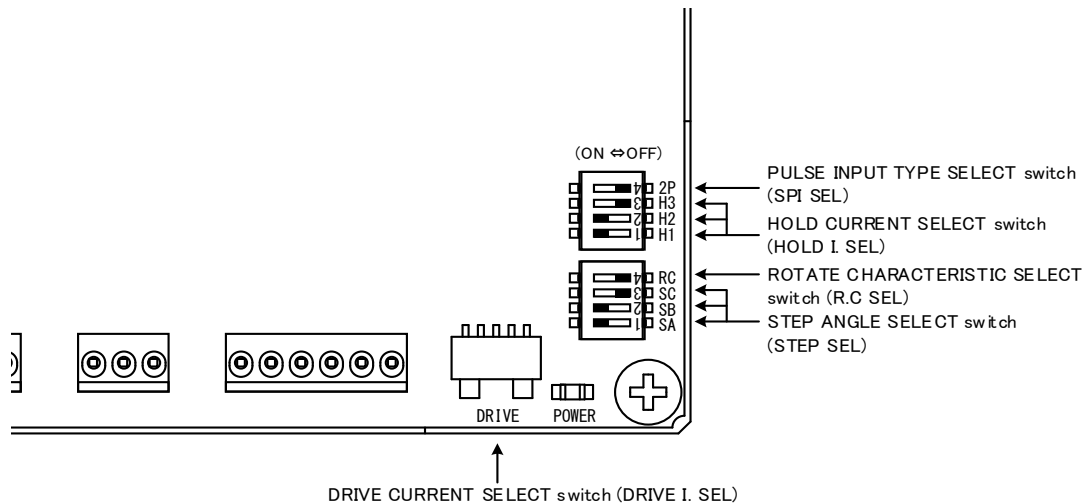

Name of Operating Section	Function	Factory Setting
DRIVE CURRENT SELECT switch	Selects DRIVE CURRENT.	[No. 7]
4 ROTATE CHARACTERISTIC SELECT switch	Selects a characteristic of motor rotation.	RC : [OFF]
3 STEP ANGLE SELECT switch		SC : [OFF]
2 STEP ANGLE SELECT switch		SB : [ON]
1 STEP ANGLE SELECT switch		SA : [ON]
4 PULSE INPUT TYPE SELECT switch	Selects a pulse input type.	2P : [OFF]
3 HOLD CURRENT SELECT switch	Selects HOLD CURRENT.	H3 : [OFF]
2 HOLD CURRENT SELECT switch		H2 : [ON]
1 HOLD CURRENT SELECT switch		H1 : [ON]

4. Function Set-up by Use

4 – 1. Setting STEP ANGLE SELECT switch

⚠ CAUTION

Erroneous setting may cause breakage of the machine or injury due to unexpected rotation of motor.
Ensure correct setting.

The step angle is set up with the STEP SEL switch.
The step angle can be selected from six different types of step angles.

(1) Set the step angle required by the STEP SEL switch [SA, SB, SC].

● Relationship between the STEP SEL switch and the step angle.

STEP SEL switch			1/ Divisions	Step angle(°)
SC	SB	SA		1.8° motor
ON	ON	ON	1/1	1.8
ON	ON	OFF	1/2	0.9
ON	OFF	ON	1/4	0.45
ON	OFF	OFF	1/8	0.225
OFF	ON	ON	1/16	0.1125
OFF	ON	OFF	1/32	0.05625
OFF	OFF	ON	–	–
OFF	OFF	OFF	–	–

(Factory setting)

4 – 2. Setting HOLD CURRENT SELECT switch

CAUTION

A high setting value may cause burn on the skin due to overheating of the motor.
Do not select a high value beyond the required.

DRIVE CURRENT is set up with the HOLD I.SEL switch.
The ratio of HOLD CURRENT to DRIVE CURRENT can be selected.

(1) Set the HOLD I.SEL switch No. to the ratio of HOLD CURRENT to DRIVE CURRENT required.

● Ratio of HOLD CURRENT

$$\text{Ratio of HOLD CURRENT (\%)} = \frac{\text{HOLD CURRENT}}{\text{DRIVE CURRENT}} \times 100$$

DRIVE I.SEL [No. 0~No. A]			
HOLD I.SEL switch			Ratio of HOLD CURRENT (%)
H3	H2	H1	
OFF	OFF	OFF	10
OFF	OFF	ON	20
OFF	ON	OFF	30
OFF	ON	ON	40 (Factory setting)
ON	OFF	OFF	50
ON	OFF	ON	60
ON	ON	OFF	70
ON	ON	ON	100

DRIVE I.SEL [No. B~No. F]			
HOLD I.SEL switch			Ratio of HOLD CURRENT (%)
H3	H2	H1	
OFF	OFF	OFF	10
OFF	OFF	ON	20
OFF	ON	OFF	30
OFF	ON	ON	40
ON	OFF	OFF	50
ON	OFF	ON	60
ON	ON	OFF	70
ON	ON	ON	—

- HOLD CURRENT changes relative to DRIVE CURRENT setting.
The ratio of HOLD CURRENT [100%] represents the same as the setting for DRIVE CURRENT.
- The effective range of the HOLD I.SEL switch varies according to the setting of the DRIVE I.SEL switch.
- The greater the ratio of HOLD CURRENT grows, the more heat the motor generates when is on holding-state.

4 – 3. Setting DRIVE CURRENT SELECT switch

⚠ CAUTION

Erroneous setting may cause burn on the skin, injury or damage to the motor due to overheating of the motor.
Ensure correct setting.

DRIVE CURRENT is set up with the DRIVE I.SEL switch.

(1) Set the switch No. to the setting specified in the table "10-5. Applicable Motors."

- Relationship between the DRIVE I.SEL switch and DRIVE CURRENT.

Switch No.	A/phase
0	0.30
1	0.40
2	0.50
3	0.60
4	0.70
5	0.80
6	0.90
7	1.00
8	1.10
9	1.20
A	1.40
B	1.50
C	1.70
D	1.80
E	1.90
F	2.00

(Factory setting)

4 – 4. Setting PULSE INPUT TYPE SELECT switch

CAUTION

Erroneous setting may cause breakage of the machine or injury due to unexpected rotation of motor.
Ensure correct setting.

Pulse input method is set up with the SPI SEL switch.
Set this switch with power OFF.

- (1) Turn power [OFF].
- (2) Set the SPI SEL [2P/1P] switch.

SPI SEL	Input type
ON	1PULSE (1P)
OFF	2PULSE (2P)

(Factory setting)

- When the motor is operated with two pulse signal inputs of CW and CCW, set the SPI SEL switch to [OFF(2P)].
- When the motor is operated with the pulse signal and direction signal input, set the SPI SEL switch to [ON(1P)].
- In the case that 1-pulse input method is selected, the CCW terminal becomes direction signal input designating the direction of the motor rotation. Drive pulse set to the CW terminal (CW+, CW-).

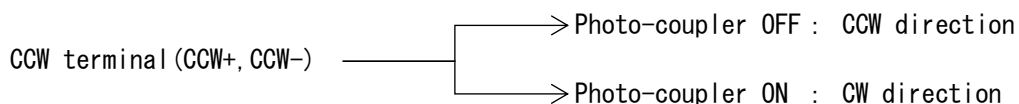

- The input timing is same with 2-pulse input method and 1-pulse input method .
As for input timing, refer to "10-2. (2) Drive pulse input (CW, CCW)"

4 – 5. Setting ROTATE CHARACTERISTIC SELECT switch

Rotate character is set up with the ROTATE CHARACTERISTIC SEL switch.

Set this switch with power OFF.

- When the division of the STEP SEL switch is 1/1 or 1/2, by setting the R.C SEL switch to [OFF] the vibration of the motor in a acceleration/deceleration drive may reduce.

5. Installation

5-1. Conditions for Installation

⚠ WARNING

Overheating may cause fire.
Mount it on a noncombustible member.
Keep it away from combustibles.

(1) Designed for incorporating into equipment used indoors, this product requires to be installed in the following environment:

- Indoors (where it is not exposed to direct sun).
- Where ambient temperature and humidity are controlled within the range set out in the specifications.
- Where there is no explosive, corrosive or inflammable gas.
- Where it can be protected from dust, salt or iron powder.
- Where the product main frame is not exposed to direct vibration or shock.
- Where it is not exposed to splashes of water, oil or chemicals.

(2) Install the driver at least 5mm away from other equipment.

However, please be installed to a distance of at least 15mm from the heating element.

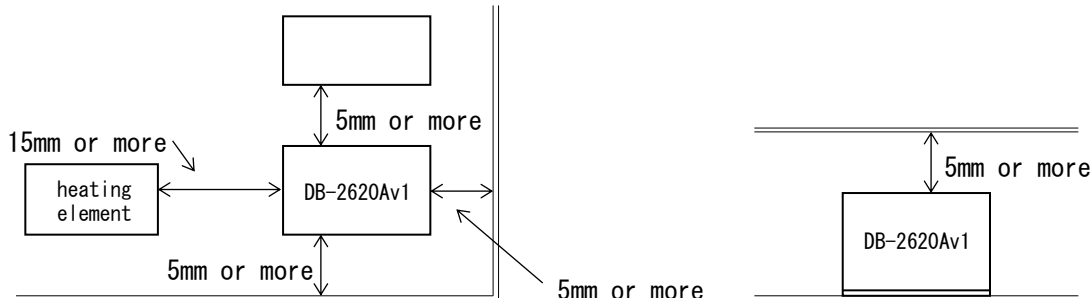

- Please contact us if you are not installed to a distance of at least 15mm from the heating element.

(3) Considering heat release, control the ambient temperature around the driver within the specified value.

- Take measures against accumulation of heat such as allowing generous space around the driver or installing a fan so that heat release is taken care of.
- Install the driver securely in contact with metal or other substance with adequate heat conductivity.

(4) In the case that the overheat alarm signal is output, perform the cooling measure of the mounting plate is enlarged or compulsion air cooling etc.
Use the driver on the condition that the overheat alarm signal is not output.

(5) Do not allow standing or placing anything heavy on the product.

5 – 2. Mounting Method

The round holes on the main frame are used.

The following items are required:

- M-3 screw (8mm or more in length): ----- 2
- M-3 spring washer: ----- 2
- M-3 flat washer: ----- 2

(1) Fix the product at the two round holes on the main frame.

● Mounting example

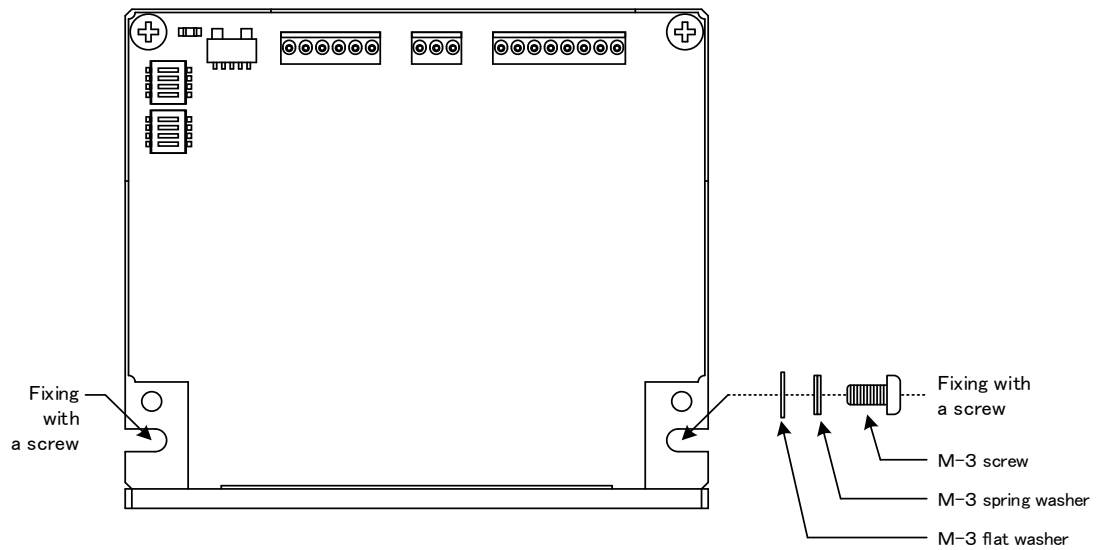
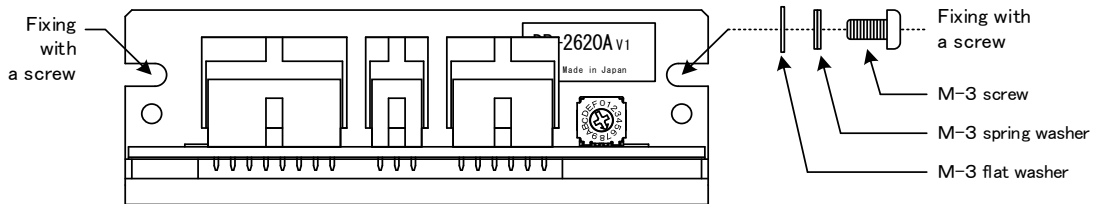

6. Connection

6-1. Overview of Connection Configuration

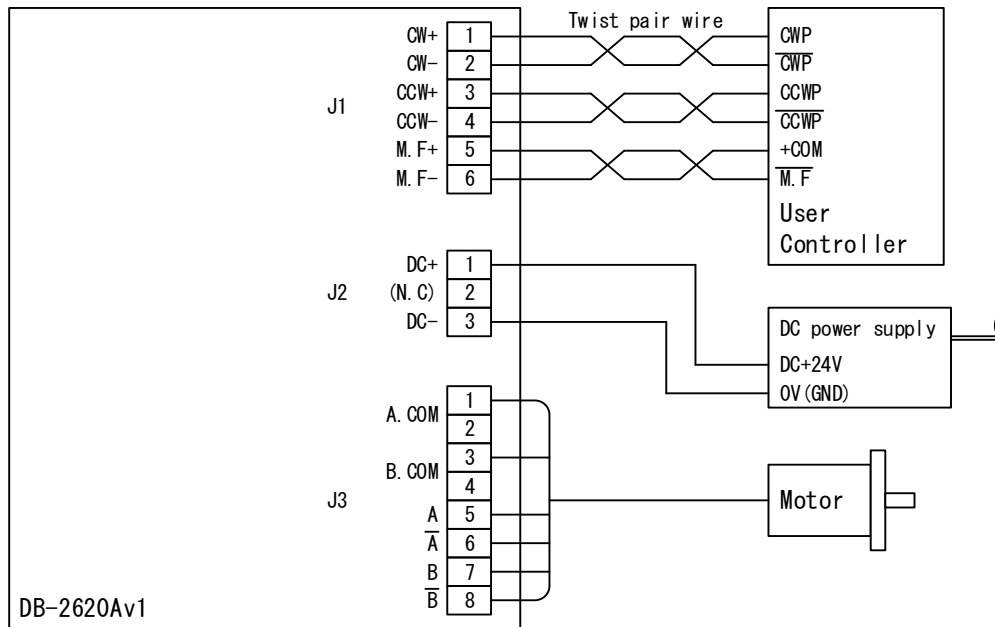

- Connect only one motor to one driver.
- Use twisted pair wire for the CW/CCW input signal line.
- Provide shielding for the signal line where considerable noise is generated.
- Use the wire material of the characteristic that is difficult to burn.
- For the driver's power supply, use a DC power supply with reinforced insulation on its primary and secondary sides.

6 – 2. Connecting Signal I/O Connector (J 1)

The following items are required:

●Housing for J1(171822-6:AMP)	One unit
●Contact for J1(170204-4:AMP)	6 contacts
●Manually operated crimping tool for AWG26-20(722560-1:AMP)	One unit

- (1) Crimp the contact to the cable used for wiring.
- (2) Insert the contact into the housing.
Make sure that the housing No. and the connector No. on the main frame are matched before inserting the contacts.
- (3) Connect the housings to the connectors on the main frame.
 - The contacts for J1 are 6 pieces.
 - When inserting, keep pushing J1 housing into the connectors until it is locked.
Also, check if the contacts are not displaced from the housing.
 - In wiring, isolate the J1 signal lines from equipment that may be a source of noise, the power line and the motor line.

(Surface on which the contacts are inserted)

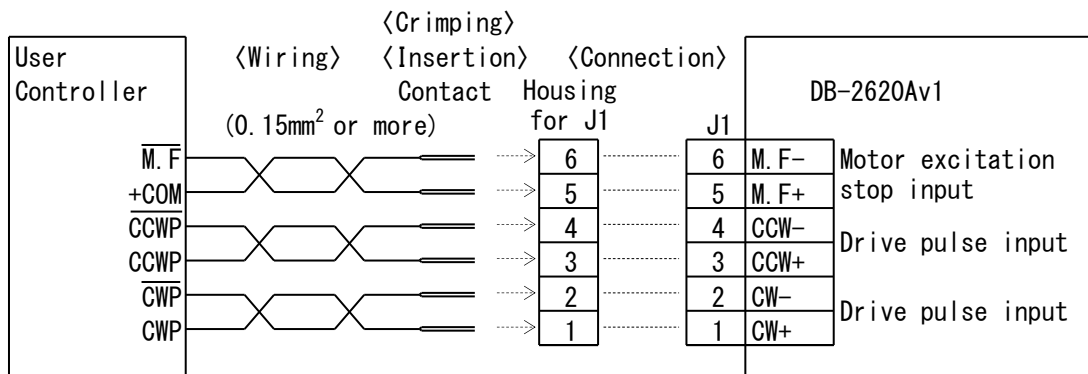
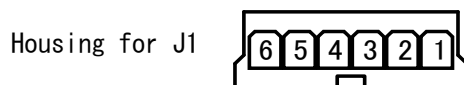

6 – 3. Connecting DC Input/Motor Output Connector (J 2 , J 3)

CAUTION

Erroneous connection may cause breakage of the motor or the driver. Correctly connect the DC Input/Motor output connector.

The following items are required:

- Housing for J2 (171822-3:AMP) One unit
- Housing for J3 (171822-8:AMP) One unit
- Contact for J2, J3 (170204-4:AMP) 8 contacts
- Manually operated crimping tool One unit
for AWG26-20 (189509-1 or 722560-1:AMP)

- (1) Crimp the contact to the cable used for wiring.
- (2) Insert the contact into the housing.
Make sure that the housing No. and the connector No. on the main frame are matched before inserting the contacts.
- (3) Connect the housings to the connectors on the main frame.
 - The contacts for J2 (for DC input) are 2 pieces, and for J3 (motor output) are 6 pieces.
 - When inserting, keep pushing J2, J3 housings into the connectors until it is locked. Also, check if the contacts are not displaced from the housing.

(Surface on which the contacts are inserted)

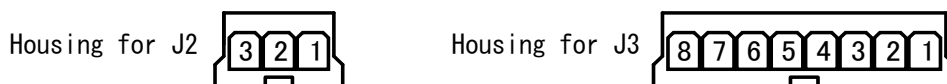

[DC input Connector]

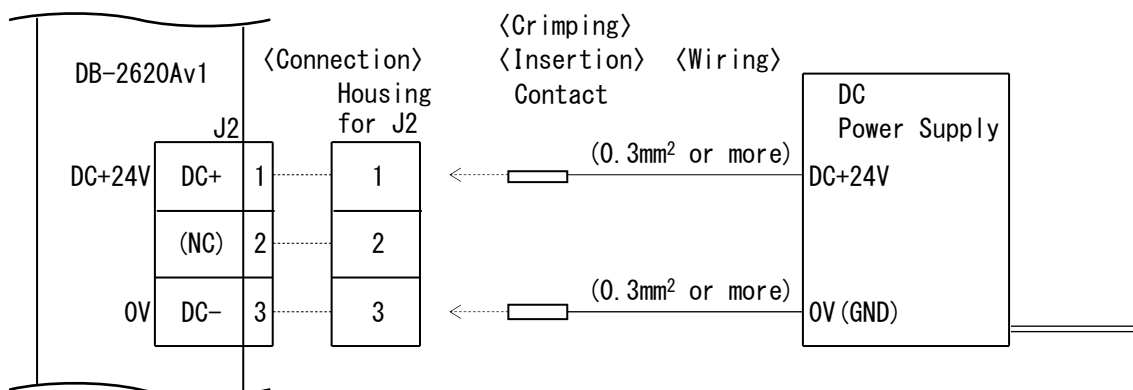

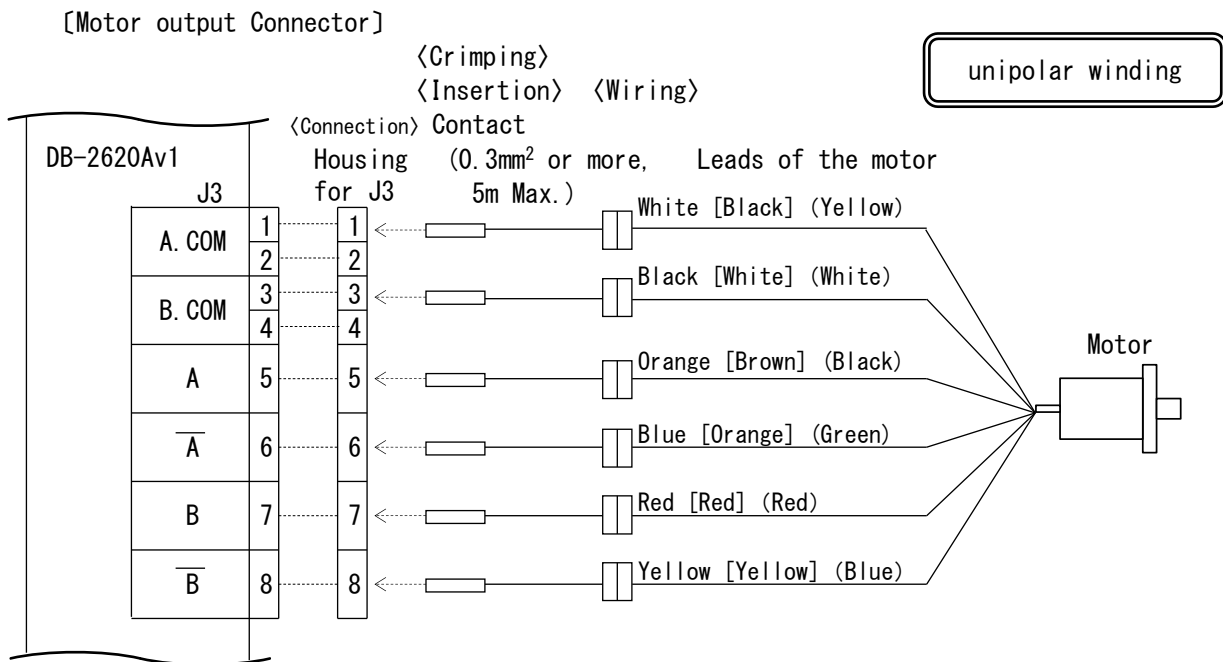

- Color indications for leads of the motor indicate motor of the SANYO DENKI CO., LTD.. Color indications for leads of the motor in parentheses [] indicate motor of the Shinano Kenshi Co., Ltd.. Color indications for leads of the motor in parentheses () indicate motor of the ORIENTAL MOTOR Co., Ltd..
- Use a cable of 5m or less for the motor cable .

6 – 4. Inputting Power

⚠ CAUTION

Breakage of the machine or injury is apprehended due to unexpected behavior of the motor. Maintain the state where emergency stop is enabled at any time.

- (1) Input the DC power supply (DC+24V) in the cable that connected to No.1 and No. 3 terminals of J2.

7. Confirmation of Setting and Connection

7 – 1. Check Points

This product requires different switch setting and motor wiring depending on the motor used.

Check if the switch setting and the motor wiring are correctly performed.

Check Points		Check	Remarks
Setting of PULSE INPUT TYPE SELECT switch	STEP SEL (SA, SB, SC)		
Setting of ROTATE CHARACTERISTIC SELECT switch	RC SEL		
Setting of HOLD CURRENT SELECT switch	HOLD I. SEL (H1, H2, H3)		
Setting of PULSE INPUT TYPE SELECT switch	SPI SEL (1P/2P)		
Setting of DRIVE CURRENT SELECT switch	DRIVE I. SEL (switch No.)		
Connection of J1			
Connection of J2	DC+, DC-		
Connection of J3	MOTOR		

8. Maintenance and Check-up

8 – 1. Maintenance and Check-up

 **WARNING**

Injury or fire is apprehended due to unexpected behavior.
Do not replace fuse.
Do not disassemble, repair or modify.

- (1) As for maintenance inspections the engineer of the specialty shall do it.
- (2) We recommend that the following check-ups should be performed periodically:
 - Checking for any loosened contact on the connectors.
 - Checking for any flaw and crack on the cabling.
- (3) In case of failure, return the driver to us and have it repaired.

8 – 2. Troubleshooting

Trouble	Check Item	Assumed Cause
1. POWER LED does not come on.	<ul style="list-style-type: none"> ▪ Connection of power supply. ▪ Value of power voltage. 	<ul style="list-style-type: none"> ▪ Wiring error with power supply. ▪ Power voltage failure. ▪ Driver failure.
2. The motor is not excited. (It can be easily rotated by hand.)	<ul style="list-style-type: none"> ▪ Connection of the motor to the driver. ▪ ON/OFF status of the M.F signal. 	<ul style="list-style-type: none"> ▪ Wiring error with the motor and the driver. ▪ The M.F signal is input. ▪ Driver failure.
3. The motor does not rotate. The motor behaves abnormally. The motor steps out.	<ul style="list-style-type: none"> ▪ The same check items as those under item 2 above. ▪ Setting of the PULSE INPUT TYPE SELECT switch. ▪ Connection of the pulse signal. ▪ Voltage and wave form of the pulse signal. ▪ Setting of the DRIVE CURRENT SELECT switch. ▪ Setting of the STEP ANGLE SELECT switch. 	<ul style="list-style-type: none"> ▪ Wrong setting for the pulse input type. ▪ Wiring error with the pulse signal line. ▪ Pulse signal of wrong specifications. ▪ DRIVE CURRENT is too low. ▪ Wrong setting for the step angle. ▪ Driver failure. ▪ Motor failure.
4. The motor steps out during acceleration.	<ul style="list-style-type: none"> ▪ Starting pulse speed. ▪ Acceleration time. 	<ul style="list-style-type: none"> ▪ Starting pulse signal speed is too high. ▪ Acceleration time is too short.
5. The motor generates excessive heat.	<ul style="list-style-type: none"> ▪ Setting of the DRIVE CURRENT SELECT switch. ▪ Value of the HOLD CURRENT SELECT switch. 	<ul style="list-style-type: none"> ▪ DRIVE CURRENT is higher than the setting for the applicable motor. ▪ The setting for HOLD CURRENT is too high.

- (1) Short-circuiting of the motor output connector may cause the driver to fail.
- The motor output connector and the power line.
 - The motor output connector and the motor output connector.
- (2) Disconnection of the motor output line may cause the driver to fail.
- Disconnection of the motor output line cable.
 - Loose connection of connector.
- (3) When a large inertial load (motor rotor inertia x 5 or more) is operated at high speed (rotational speed 20s^{-1} or more), regenerative energy will generate and increase the power supply voltage, which can damage the driver. Review the operating condition and make sure regenerative voltage will not generate.

When the failure phenomenon cannot be remedied, contact our office.

9. Storing and Disposal

9 – 1. Storing

(1) Keep the product in the following environment:

- Indoors (where it is not exposed to direct sun).
- Where ambient temperature and humidity are controlled within the range set out in the specifications.
- Where there is no explosive, corrosive or inflammable gas.
- Where it can be protected from dust, salt or iron powder.
- Where the product main frame is not exposed to direct vibration or shock.
- Where it is not exposed to splashes of water, oil or chemicals.

(2) Do not allow standing or placing anything heavy on the product.

9 – 2. Disposal

(1) Dispose of the product as industrial waste.

1 0. Specifications

1 0 – 1. General Specifications

Supply Power	DC+24V *1 (Ripple voltage P-P 2.0V or less) ●Rated input current : [DRIVE I. SEL ⇒ No.F set up] at DRIVE DC+24V: 2.5A *2 ●Rated input current : [HOLD I. SEL ⇒ Approx. 40% set up] at HOLD DC+24V: 0.6A	
Driving method	Unipolar constant current type	
Motor output current	●DRIVE CURRENT 0.30A/phase~2.00A/phase ●HOLD CURRENT Approx. 40% of DRIVE CURRENT (factory-set)	
Input Signal	●Drive pulse input (CW, CCW) Photo-coupler input ●Motor excitation stop input (M.F) Photo-coupler input	
Functions of Operating Sections	●STEP ANGLE selection (STEP SEL) ●HOLD CURRENT selection (HOLD I. SEL) ●DRIVE CURRENT selection (DRIVE I. SEL) ●PULSE INPUT TYPE selection (SPI SEL) ●ROTATE CHARACTERISTIC selection (R.C SEL)	
Operating Ambient Temperature	0°C ~ +40°C (No freezing allowed.)	
Operating Ambient Humidity	80%RH 以下 (No condensation allowed.)	
Storing Temperature	-10°C ~ +55°C (No freezing allowed.)	
Storing Humidity	80%RH or less (No condensation allowed.)	
Altitude	Up to 1000m above sea level	
Atmosphere	Indoor (Exposure to direct sun is not allowed.) Without any explosive, corrosive or inflammable gas, oil mist, or dust.	
Withstanding Vibration	No abnormality should be found after a vibration test at 10~55Hz, 0.15mm P-P	
Insulation resistance	DC connector - signal connector - Frame (Each other)	DC500V 100MΩ or more
Exterior Dimensions	H77 × W88 × D30 (mm)	
Weight	0.11kg	

*1 Input voltage range is DC+24V±10%.

*2 Use a power supply that provides sufficient input current.

1 0 – 2. I/O Signal

(1) Example Circuit Connection

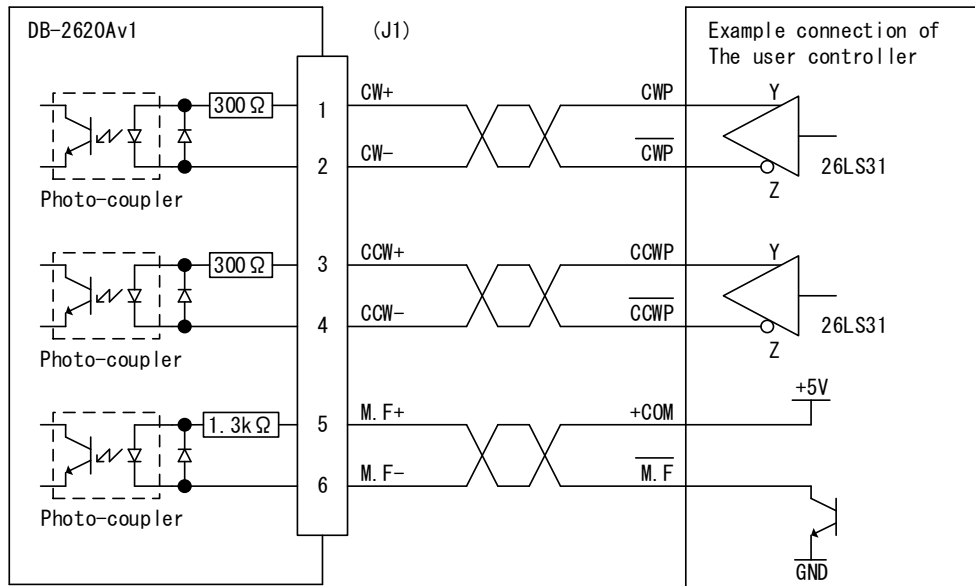

(2) Drive pulse input (CW, CCW)

- ① Operating current range : 5mA~14mA
The photo-coupler turns on with inter-terminal voltage of 3.1 V~5.5 V.
(Photo-coupler diode $V_f \doteq 1.5$ V)

② Timing chart

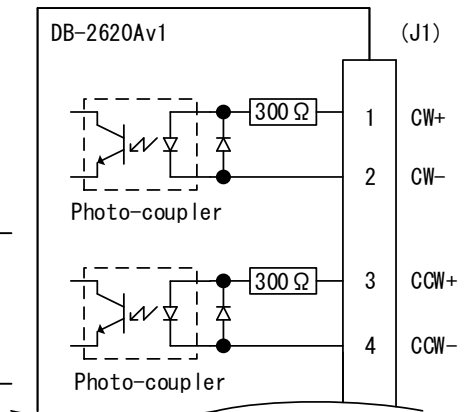
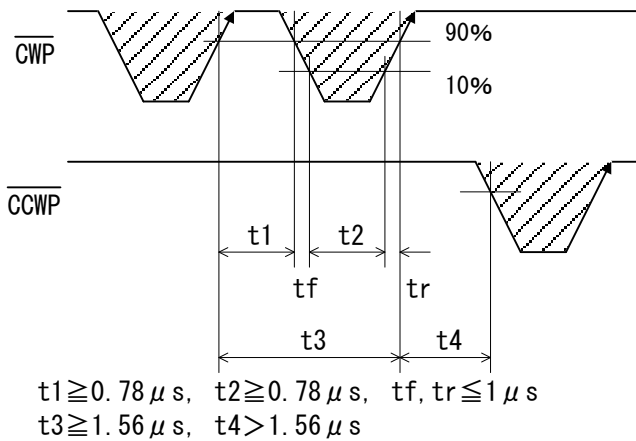

[To the line driver 26LS31]

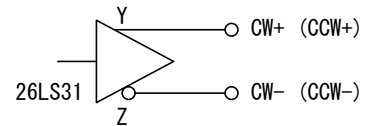

Maximum response frequency : 640kHz
(at 50% duty)

- The shaded area () indicates light emission from the photo-coupler, and the motor is driven at the rising edge ().
"t4" greatly varies according to the inertial moment including that of the motor.

③ Automatic switching for DRIVE/HOLD

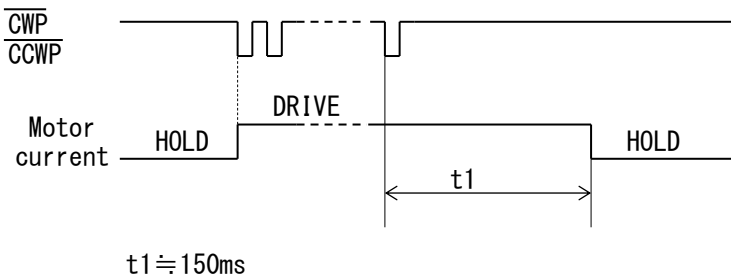

- Inputting drive pulse causes the current output to the motor to change from HOLD CURRENT to DRIVE CURRENT, which returns to HOLD CURRENT in about "t1".
DRIVE CURRENT continues if pulse is input on driving-state.

④ Direction of rotation

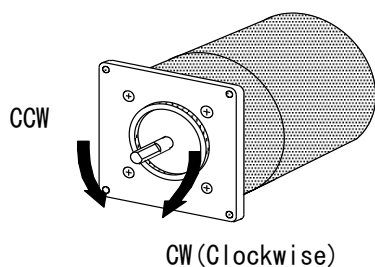

(3) Motor excitation stop input (M.F)

CAUTION

Deterioration of the holding power with the motor may cause breakage of the machine or injury.
Check safety before inputting.

- ① Operating current range : 2.6mA~19.5mA
The photo-coupler turns on with inter-terminal voltage of 4.5 V~26.4 V.
(Photo-coupler diode $V_F \doteq 1.1$ V)

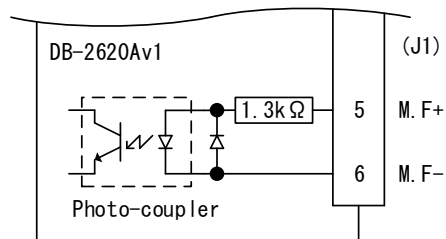

- Motor output current is shut off with the photo-coupler ON.
At this time, motor torque changes to detent torque.
- When this signal is input, motor torque may be lost, resulting in failure to retain the load transported.
In particular, this risk is high with the vertical drive (such as the Z-axis).

② Timing chart

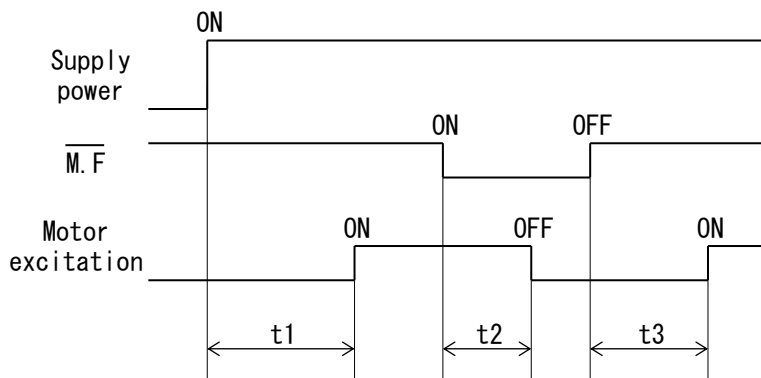

- $t1 \leq 300\text{ms}$ ($t1$: Time required for the motor to be enabled.)
 $t2 \leq 5\text{ms}$ ($t2$: Time required for the motor output current to be shut off.)
 $t3 \leq 100\text{ms}$ ($t3$: Time required for the motor to be enabled.)

1 0 - 3. Dimensions

(Unit : mm)

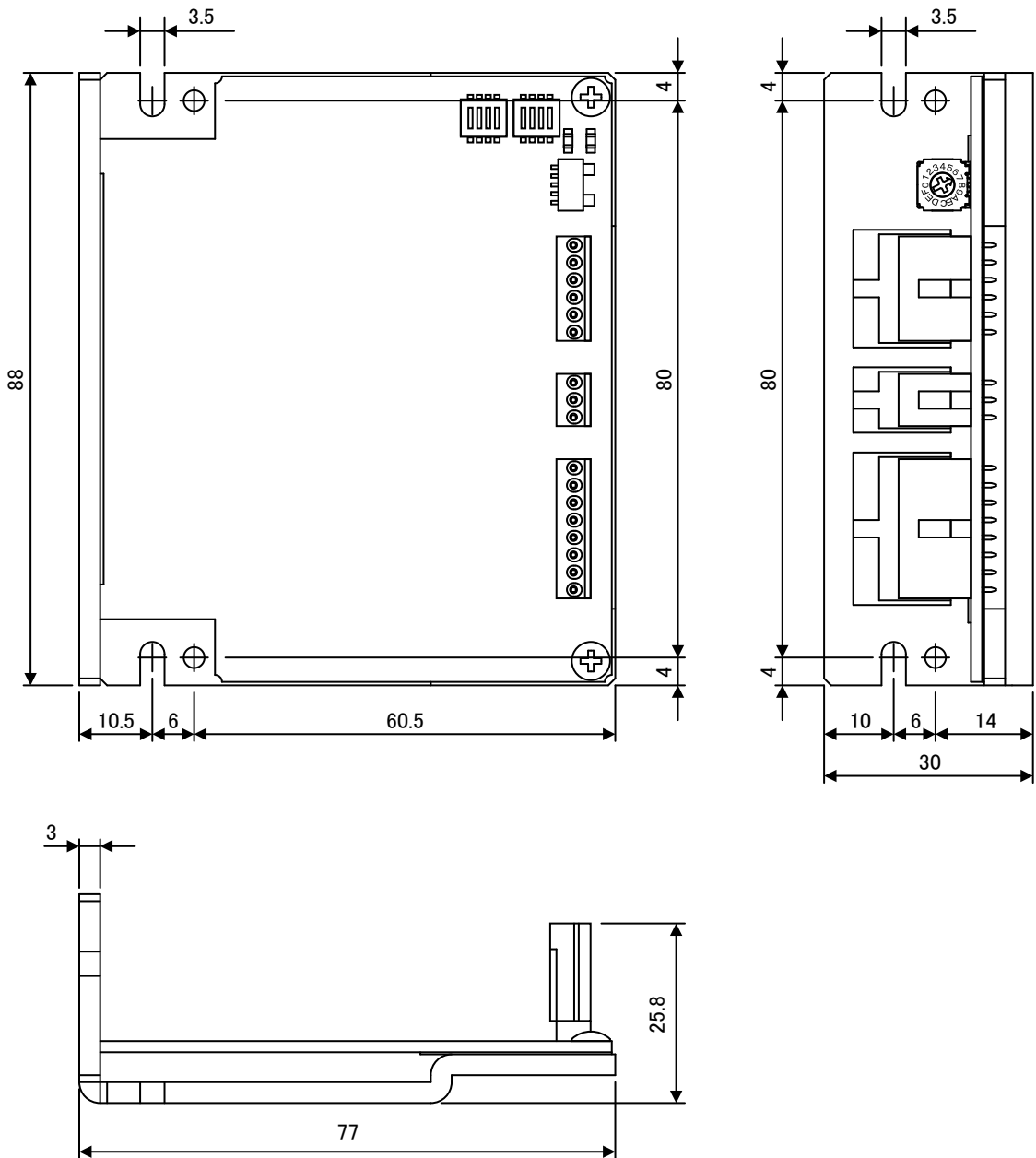

1 0 – 4. Applicable Motors

R1

- DB-2620Av1 can drive a 2-phase stepping motor of unipolar winding ranging from 0.4A/phase to 2.0A/phase.

SANYO DENKI CO., LTD.		Basic Angle (°)	Current (A/phase)	Setting DRIVE I. SEL switch No.	Torque Data Fig. No.
□56mm	103H7121-0140 (0110)	1.8	1.0	7	Fig. 1
	103H7123-0140 (0110)	1.8	1.0	7	Fig. 2
	103H7126-0140 (0110)	1.8	1.0	7	Fig. 3
□56mm	103H7121-0440 (0410)	1.8	2.0	F	Fig. 4
	103H7123-0440 (0410)	1.8	2.0	F	Fig. 5
	103H7126-0440 (0410)	1.8	2.0	F	Fig. 6
Shinano Kenshi Co., Ltd.		Basic Angle (°)	Current (A/phase)	Setting DRIVE I. SEL switch No.	Torque Data Fig. No.
□42mm	P-PMSA-U42D3M (U42D3MD)	1.8	0.8	5	Fig. 7
□28mm	P-PMSB-U28DA1 (U28DA1D)	1.8	1.0	7	Fig. 8
□42mm	P-PMSA-U42D2 (U42D2D)	1.8	1.2	9	Fig. 9
□56.4mm	P-PMSA-U56D1 (U56D1D)	1.8	2.0	F	Fig. 10
	P-PMSA-U56D3 (U56D3D)	1.8	2.0	F	Fig. 11
	P-PMSA-U56D5 (U56D5D)	1.8	2.0	F	Fig. 12
ORIENTAL MOTOR Co., Ltd.		Basic Angle (°)	Current (A/phase)	Setting DRIVE I. SEL switch No.	Torque Data Fig. No.
□28mm	PKP223U09A2 (B2)	1.8	0.95	6	Fig. 13
	PKP225U09A2 (B2)	1.8	0.95	6	Fig. 14
□42mm	PK243-01A (B)	1.8	0.95	6	Fig. 15
□56.4mm	PK264-01A (B)	1.8	1.0	7	Fig. 16
	PK266-01A (B)	1.8	1.0	7	Fig. 17
	PK268-01A (B)	1.8	1.0	7	Fig. 18
□42mm	PK244-01A (B)	1.8	1.2	9	Fig. 19
	PK245-01A (B)	1.8	1.2	9	Fig. 20
□56.4mm	PK264-02A (B)	1.8	2.0	F	Fig. 21
	PK266-02A (B)	1.8	2.0	F	Fig. 22
	PK268-02A (B)	1.8	2.0	F	Fig. 23
Factory Setting				7	—

() : Both axis

- Please contact us if you want to use the motor other than the above to our office.

1 0 – 5. Torque Characteristics

- (1) Representations in the torque characteristics table are made in terms of the motor rotation (s^{-1}) vs. torque ($N \cdot m$).
Motor rotation (s^{-1}) and drive pulse frequency (Hz) are converted as follows:

$$\text{Motor rotation}(s^{-1}) \times \frac{360^{\circ}}{\text{Step angle}} = \text{Drive pulse input frequency(Hz)}$$

- (2) The Maximum Starting Pulse Rate is represented as "fs" by the value at zero inertial load.
- (3) Upon operation, provide adequate allowance for torque.
- (4) The stepping motor may attain high temperature, depending on the operational conditions.
Use the stepping motor according to the Instructions Manual produced by motormakers.

Fig. 1

DB-2620Av1
103H7121-0140 (0110)
1.0A/PHASE

DRIVE I. SEL = No. 7 (1.0A/PHASE)
DC24V

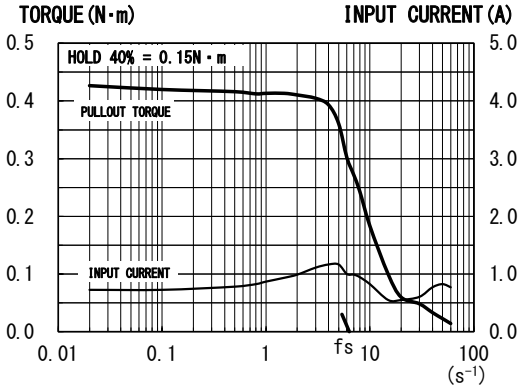

Fig. 2

DB-2620Av1
103H7123-0140 (0110)
1.0A/PHASE

DRIVE I. SEL = No. 7 (1.0A/PHASE)
DC24V

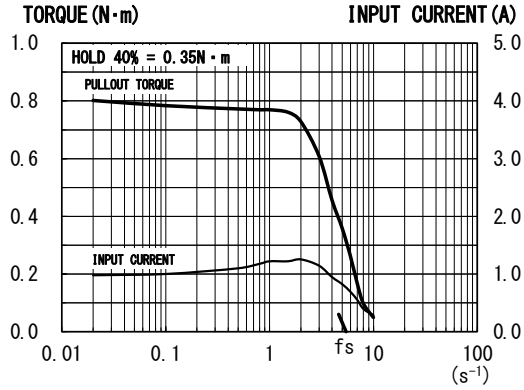

Fig. 3

DB-2620Av1
103H7126-0140 (0110)
1.0A/PHASE

DRIVE I. SEL = No. 7 (1.0A/PHASE)
DC24V

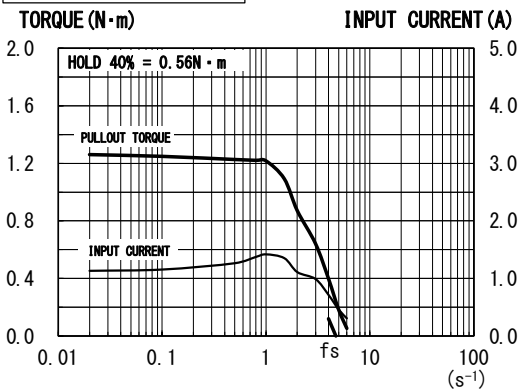

Fig. 4

DB-2620Av1
103H7121-0440 (0410)
2.0A/PHASE

DRIVE I. SEL = No. F (2.0A/PHASE)
DC24V

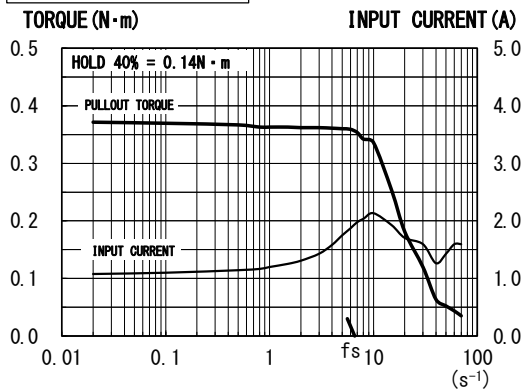

Fig. 5

DB-2620Av1
103H7123-0440 (0410)
2.0A/PHASE

DRIVE I. SEL = No. F (2.0A/PHASE)
DC24V

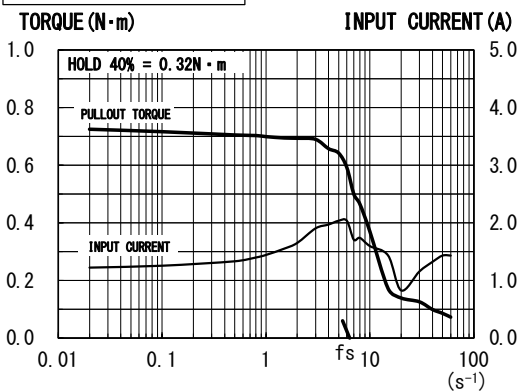

Fig. 6

DB-2620Av1
103H7126-0440 (0410)
2.0A/PHASE

DRIVE I. SEL = No. F (2.0A/PHASE)
DC24V

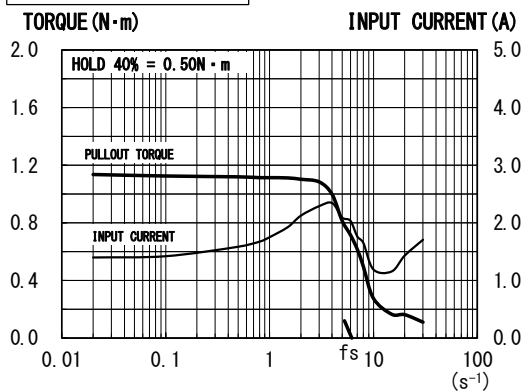

Fig. 7

DB-2620Av1
P-PMSA-U42D3M (U42D3MD)
0.8A/PHASE

DRIVE I. SEL = No. 5 (0.8A/PHASE)
DC24V

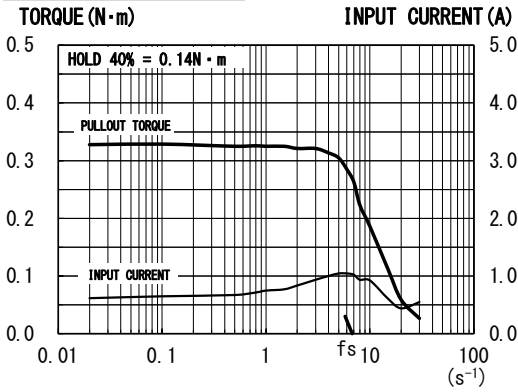

Fig. 8

DB-2620Av1
P-PMSB-U28DA1 (U28DA1D)
1.0A/PHASE

DRIVE I. SEL = No. 7 (1.0A/PHASE)
DC24V

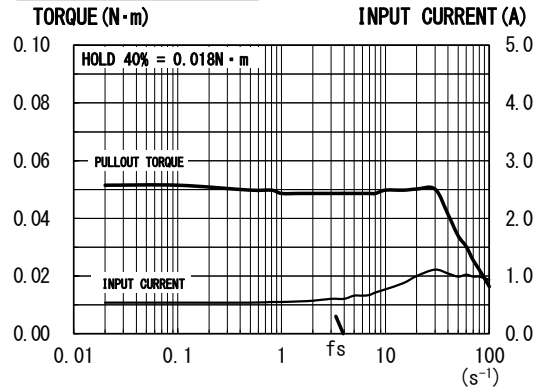

Fig. 9

DB-2620Av1
P-PMSA-U42D2 (U42D2D)
1.2A/PHASE

DRIVE I. SEL = No. 9 (1.2A/PHASE)
DC24V

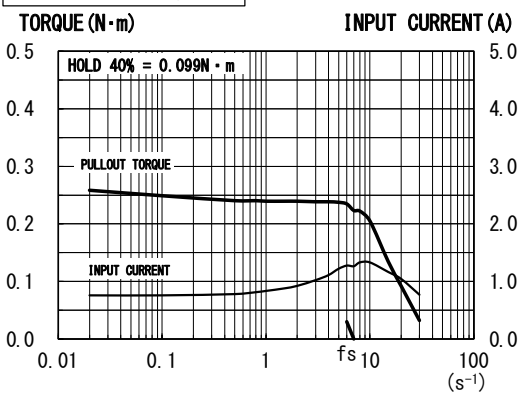

Fig. 10

DB-2620Av1
P-PMSA-U56D1 (U56D1D)
2.0A/PHASE

DRIVE I. SEL = No. F (2.0A/PHASE)
DC24V

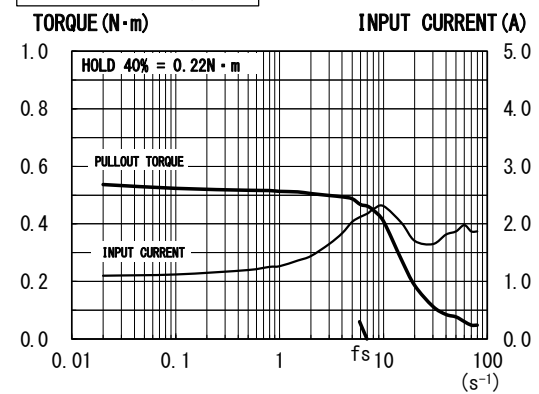

Fig. 11

DB-2620Av1
P-PMSA-U56D3 (U56D3D)
2.0A/PHASE

DRIVE I. SEL = No. F (2.0A/PHASE)
DC24V

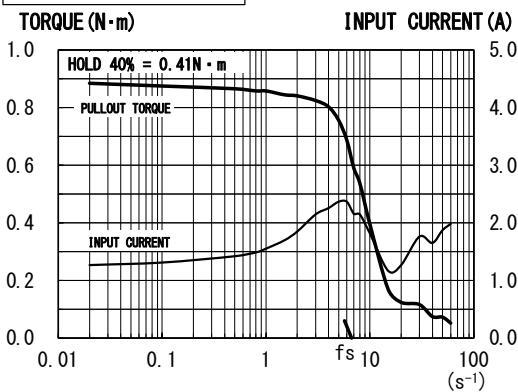

Fig. 12

DB-2620Av1
P-PMSA-U56D5 (U56D5D)
2.0A/PHASE

DRIVE I. SEL = No. F (2.0A/PHASE)
DC24V

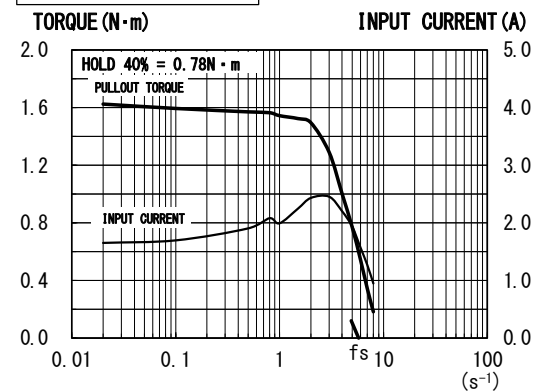

Fig. 13

DB-2620Av1
PKP223U09A2 (B2)
0.95A/PHASE

DRIVE I. SEL = No. 6 (0.9A/PHASE)
DC24V

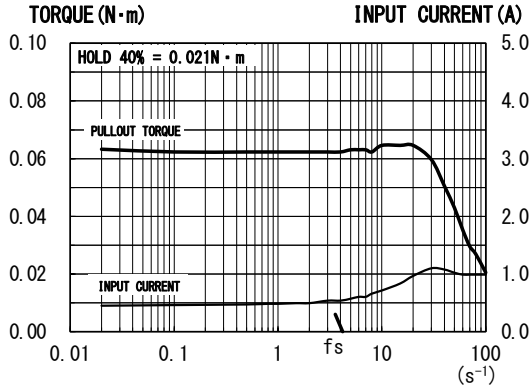

Fig. 14

DB-2620Av1
PKP225U09A2 (B2)
0.95A/PHASE

DRIVE I. SEL = No. 6 (0.9A/PHASE)
DC24V

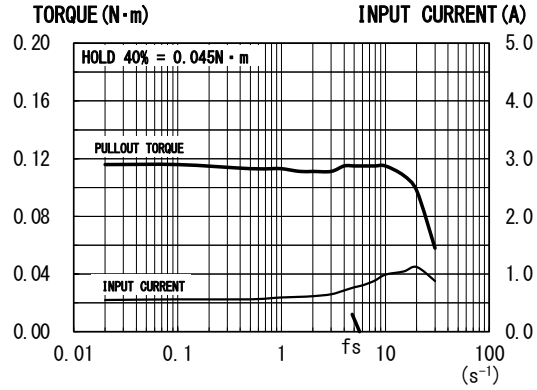

Fig. 15

DB-2620Av1
PK243-01A (B)
0.95A/PHASE

DRIVE I. SEL = No. 6 (0.9A/PHASE)
DC24V

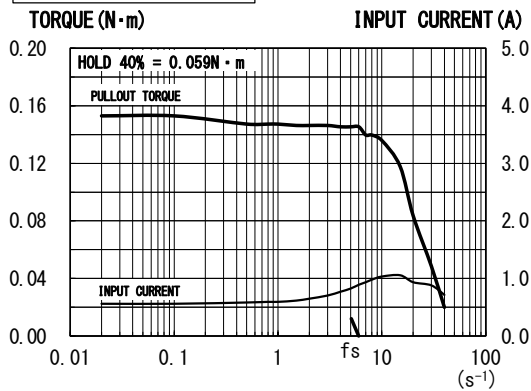

Fig. 16

DB-2620Av1
PK264-01A (B)
1.0A/PHASE

DRIVE I. SEL = No. 7 (1.0A/PHASE)
DC24V

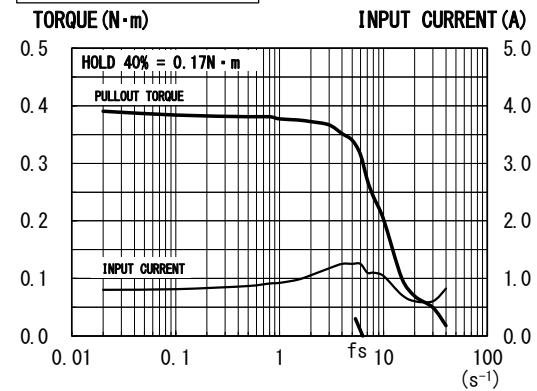

Fig. 17

DB-2620Av1
PK266-01A (B)
1.0A/PHASE

DRIVE I. SEL = No. 7 (1.0A/PHASE)
DC24V

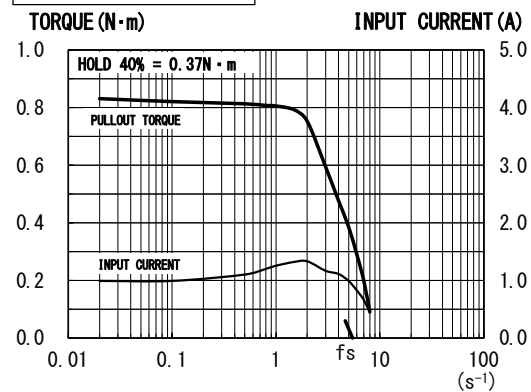

Fig. 18

DB-2620Av1
PK268-01A (B)
1.0A/PHASE

DRIVE I. SEL = No. 7 (1.0A/PHASE)
DC24V

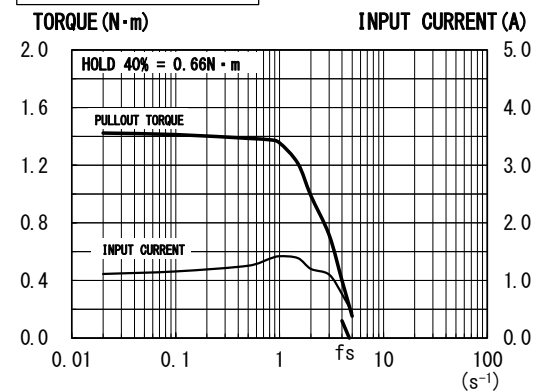

Fig. 19

DB-2620Av1
PK244-01A(B)
1.2A/PHASE

DRIVE I. SEL = No. 9 (1.2A/PHASE)
DC24V

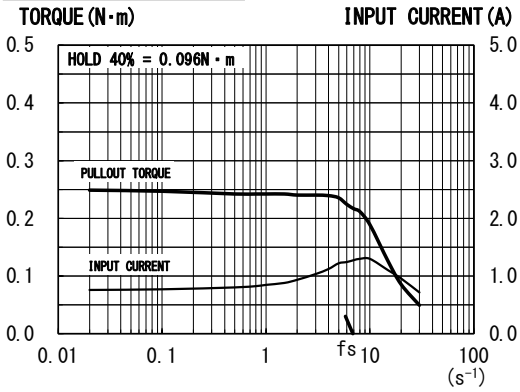

Fig. 20

DB-2620Av1
PK245-01A(B)
1.2A/PHASE

DRIVE I. SEL = No. 9 (1.2A/PHASE)
DC24V

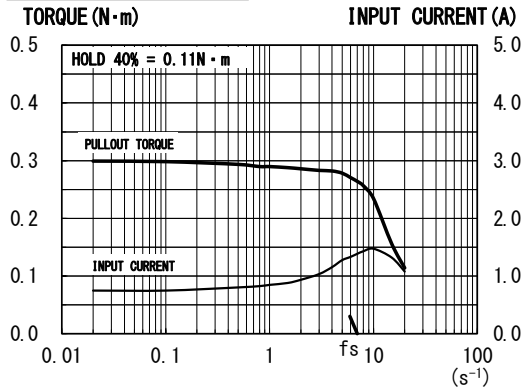

Fig. 21

DB-2620Av1
PK264-02A(B)
2.0A/PHASE

DRIVE I. SEL = No. F (2.0A/PHASE)
DC24V

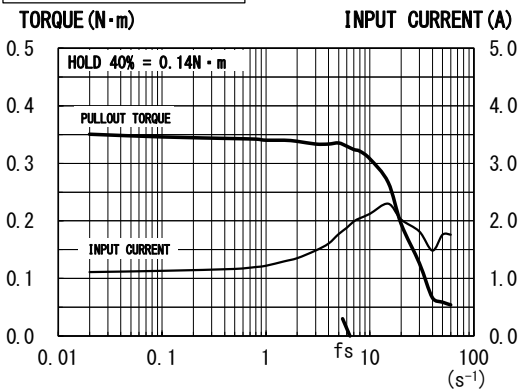

Fig. 22

DB-2620Av1
PK266-02A(B)
2.0A/PHASE

DRIVE I. SEL = No. F (2.0A/PHASE)
DC24V

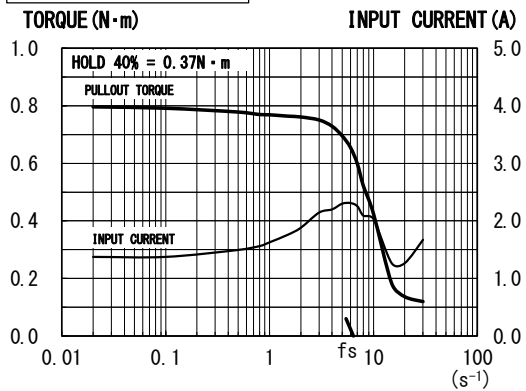
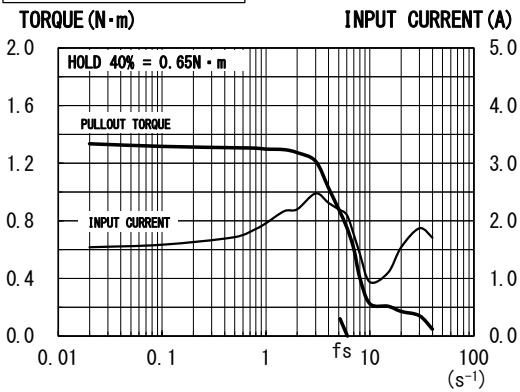

Fig. 23

DB-2620Av1
PK268-02A(B)
2.0A/PHASE

DRIVE I. SEL = No. F (2.0A/PHASE)
DC24V



10-6. Conforming to Europe standards

(1) Low voltage directive

This product is not subject to the EC's Low Voltage Directive by the following.

- This product should be installed within an enclosure.
- For the driver's power supply, use a DC power supply with reinforced insulation on its primary and secondary sides.

(2) EMC directive

This product declares the CE marking based on the EMC(2014/30/EU) Directive by oneself.

● Applicable Standards

EN61000-6-4
EN61000-6-2

● This product conducted EMC measurement with the system configuration for EMC.

- EMC characteristic may vary depending on the configuration of the equipment that contains the driver or stepping motor. Be sure to conduct EMC measurement with the product assembled in your equipment.

Configuration

The metallic enclosure and shielded wires and ferrite core work to shield noise.

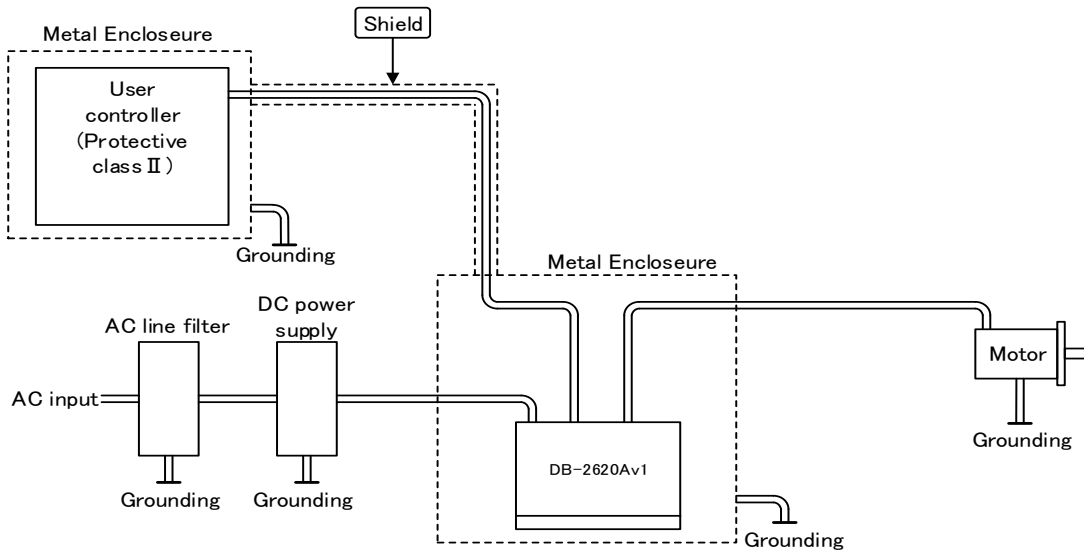

The main parts which revised by this manual

Parts	Content
P9, P31	【R1】 • Driven motor current range from 0.8A/phase to 2.0A/phase → from 0.4A/phase to 2.0A/phase

Technical Service

TEL. (042) 664-5382 FAX. (042) 666-5664
E-mail s-support@melec-inc.com

Sales and Service

TEL. (042) 664-5384 FAX. (042) 666-2031
URL:<http://www.melec-inc.com>

Melec Inc. Control equipment marketing department
516-10, Higashiasakawa-cho, Hachioji-shi, Tokyo 193-0834, Japan

This Operating Manual is subject to change without prior notice
for the purpose of product improvement.

C1610