

Melec

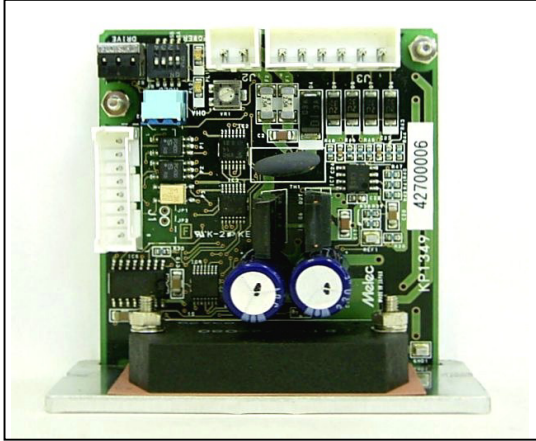

2-phase Stepping Motor Driver

DB-2630/U16

Instructions Manual (For designers' use)

USER'S MANUAL

Please ensure to read and understand this Instructions Manual before using the product. Please keep this Instructions Manual at hand so that it is always available for reference.

MN0062-2

Introduction

This Instructions Manual describes the safe and proper method of handling "2-phase Stepping Motor Driver DB-2630/U16" with emphasis on the specifications, assuming that our readers are engaged in designing of control devices incorporating stepping motors.

Please ensure to read and understand this Instructions Manual before using the product.

Please keep this Instructions Manual at hand so that it is always available for reference.

Descriptions in this manual on safety matters:

This product must be operated and used properly.

Otherwise , or when it is operated and used erroneously, unforeseen accidents may occur, causing physical injuries or property damages.

Majority of these accidents can be avoided if you are well informed of hazardous circumstances in advance.

Consequently, this instructions manual describes all the hazardous and dangerous circumstances and situations which can be foreseen and anticipated as well as necessary precautions.

All the above descriptions are being titled by the following symbol-marks and signal-words, namely:



Represents warnings ignorance of which can cause accidents involving fatal or serious physical injuries.



Represents cautions ignorance of which can cause accidents involving minor physical injuries or property damages.

Introduction

Descriptions in this manual on safety matters:

	CONTENTS	PAGE
1. Safety		
1-1. Safety Precautions		6
1-2. Safety Information for Handling		7
2. Overview		
2-1. Characteristics		10
2-2. Product Configuration		10
2-3. Appearance		10
3. Name and Function of Each Section		
3-1. Signal Input Connector		11
3-2. DC Input/Motor Output Connector (J2, J3)		12
3-3. POWER LED		12
3-4. O. H. A LED		12
3-5. Operating Section		13
4. Function Set-up by Use		
4-1. Setting STEP ANGLE SELECT switch		14
4-2. Setting HOLD CURRENT ADJUSTMENT trimmer		15
4-3. Setting DRIVE CURRENT SELECT switch		16
5. Installation		
5-1. Conditions for Installation		17
5-2. Mounting Method		18
6. Connection		
6-1. Overview of Connection Configuration		19
6-2. Connecting Signal Input Connector		20
6-3. Connecting DC Input/Motor Output Connector (J2, J3)		21
6-4. Inputting Power		22
7. Confirmation of Setting and Connection		
7-1. Check Points		23

	PAGE
8. Maintenance and Check-up	
8-1. Maintenance and Check-up	24
8-2. Troubleshooting	25
9. Storing and Disposal	
9-1. Storing	26
9-2. Disposal	26
10. Specifications	
10-1. General Specifications	27
10-2. Input Signal	
(1) Example Circuit Connection	28
(2) Drive pulse input (CW, CCW)	29
(3) Motor excitation stop input (M. F)	30
10-3. Overheat alarm(O. H. A)LED	31
10-4. Dimensions	32
10-5. Applicable Motors	33
10-6. Torque Characteristics	34

1. Safety

1 – 1. Safety Precautions

- (1) This product is not designed or manufactured for application for equipment requiring high level of reliability such as equipment related to nuclear energy, aeronautics-related equipment, automobiles, ships, medical appliances directly handling the human body and equipment that might seriously affect properties.
- (2) This product is for a devices inclusion.
Please establish it into enclosure without fail.
- (3) Ensure to use this product according to the method specified in the Instructions Manual and within the specifications.
- (4) Depending on the operational conditions, the stepping motor may step out when it is on holding-state or driving-state.
In particular, the load in transport may fall if the motor steps out on the vertical drive (such as the Z-axis).
Start operation after test run for deliberate confirmation of operation.
- (5) The stepping motor may attain high temperature, depending on the operational conditions.
If the surface temperature exceeds 100°C, provide cooling measures to control it to operate at 100°C at the highest.
- (6) Please do not touch the driver during after operation for a while,
may cause burn on the skin due to overheating of the driver.
- (7) Provide fail-safe measures so that the entire system may operate in a safe mode even in cases of the external power supply failure, disconnection of the signal line, or any failure on the driver.

1 – 2. Safety Information for Handling

●Overall:

 CAUTION

Please do not touch the driver during after operation for a while, it may cause burn on the skin due to overheating of the driver.

●When setting up the STEP ANGLE SELECT switch:

 CAUTION

Erroneous setting may cause breakage of the machine or injury due to unexpected rotation of the motor. Ensure correct setting.

●When setting up the HOLD CURRENT ADJUSTMENT trimmer:

 CAUTION

A high setting value may cause burn on the skin due to overheating of the motor. Do not select a high value beyond the required.

●When setting up the DRIVE CURRENT SELECT switch:

 CAUTION

Erroneous setting may cause burn on the skin due to overheating of the motor. Ensure correct setting.

●When installing:

 **WARNING**

Overheating may cause fire.
Mount it on a noncombustible member.
Keep it away from combustibles.

●When connecting the DC Input/Motor Output Connectors (J2, J3):

 **CAUTION**

Erroneous connection may result
in breakage of the motor or the driver.
Correctly connect the motor wiring.

●When inputting power:

 **CAUTION**

Breakage of the machine or injury is
apprehended due to unexpected behavior of
the motor. Maintain the state where
emergency stop is enabled at any time.

●When performing maintenance and checking:

 **WARNING**

Injury or fire is apprehended due to
unexpected behavior.
Do not replace fuse.
Do not disassemble, repair or modify.

- When inputting the motor excitation stop (M.F) signal:

 CAUTION

Deterioration of the holding power with the motor may cause breakage of the machine or injury.
Check safety before inputting.

- When the overheat alarm (O.H.A) LED comes on:

 WARNING

Overheating may cause fire.
Stop operation when this LED comes on.

2. Overview

2-1. Characteristics

DB-2630/U16 is a driver for a 2-phase stepping motor with DC +24V input.

It can drive a 2-phase stepping motor of unipolar winding ranging from 0.4A/phase ~ 2.0A/phase.

Four step angles can be selected from angles ranging from a 1/1, 1/2, 1/8 and 1/16 division of the basic angle.

HOLD CURRENT can be set up.

2-2. Product Configuration

The product consists of the main frame and the accessories.

●DB-2630/U16	One unit
●Housing for J1 (51103-0800:Molex)	One unit (accessory)
●Housing for J2 (51103-0200:Molex)	One unit (accessory)
●Housing for J3 (51103-0600:Molex)	One unit (accessory)
●Contact for J1 (50351-8100:Molex)	8 contacts (accessories, 2 for spares)
●Contact for J2, J3 (50271-9101:Molex)	10 contacts (accessories, 2 for spares)

2-3. Appearance

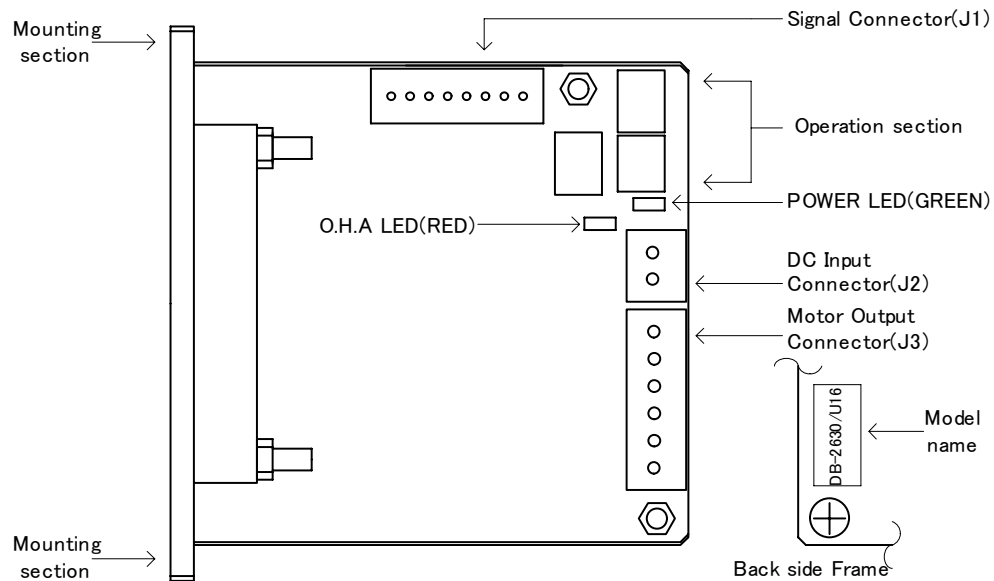

3. Name and Function of Each Section

3 - 1. Signal Input Connector (J 1)

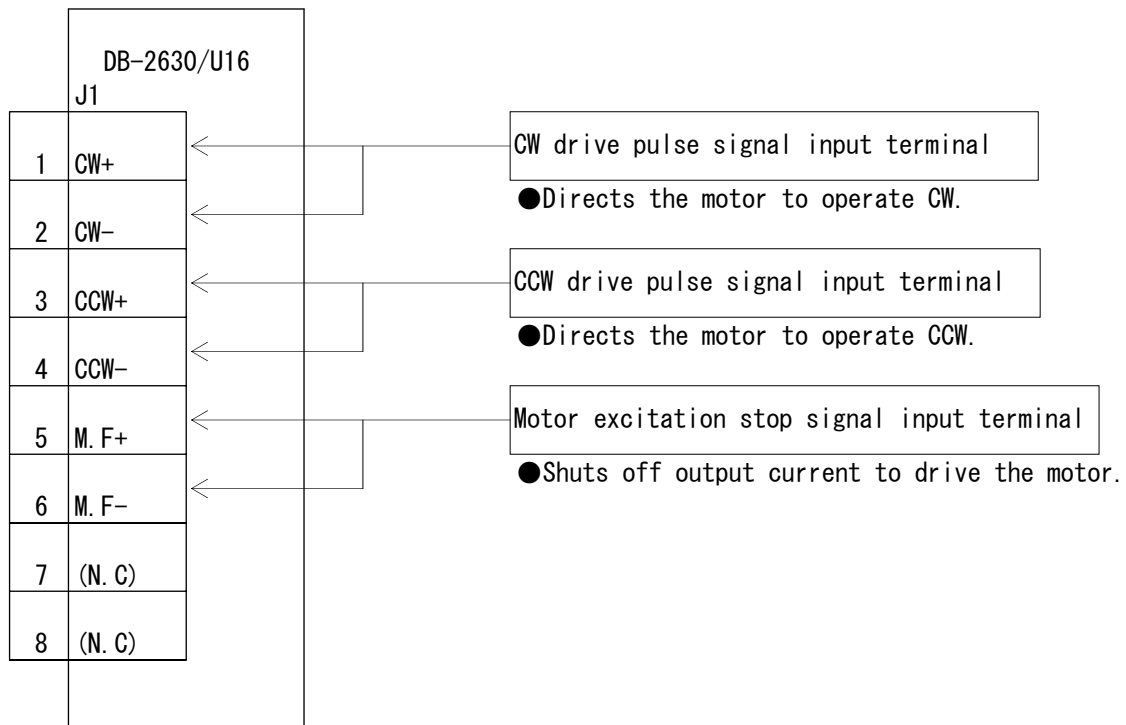

3 – 2. DC Input/Motor Output Connector (J 2, J 3)

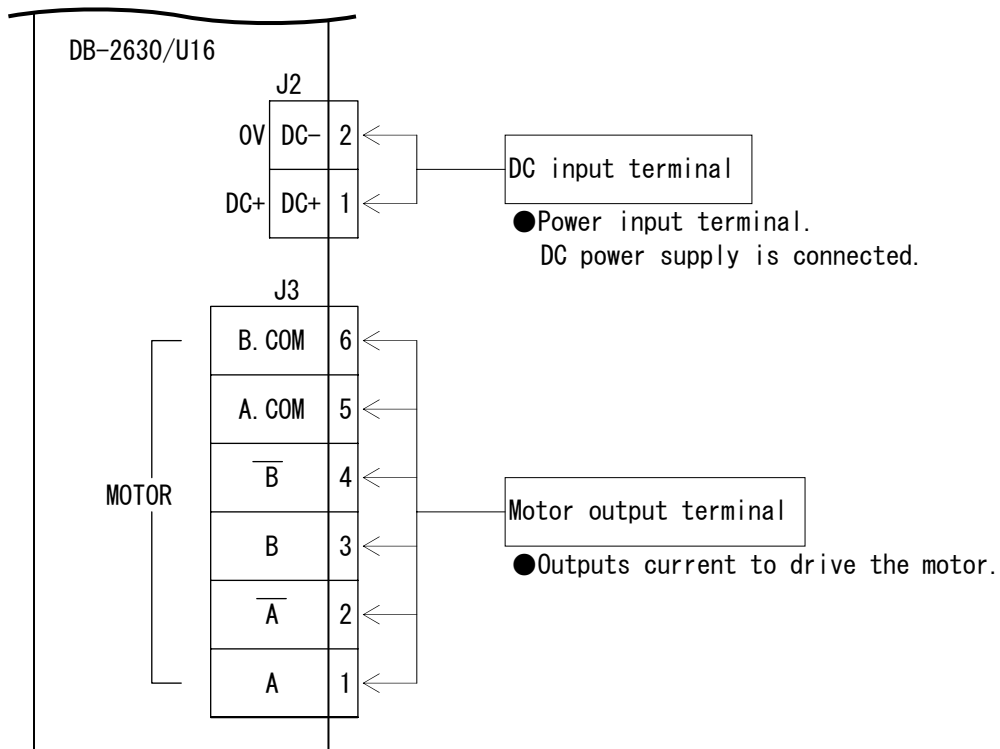

3 – 3. POWER LED

POWER LED (GREEN) comes on upon inputting power.

3 – 4. O.H.A LED

O. H. A LED (RED) comes on when internal temperature of the driver has reached approx. 70°C or more.

3 – 5. Operation Section

DB-2630/U16

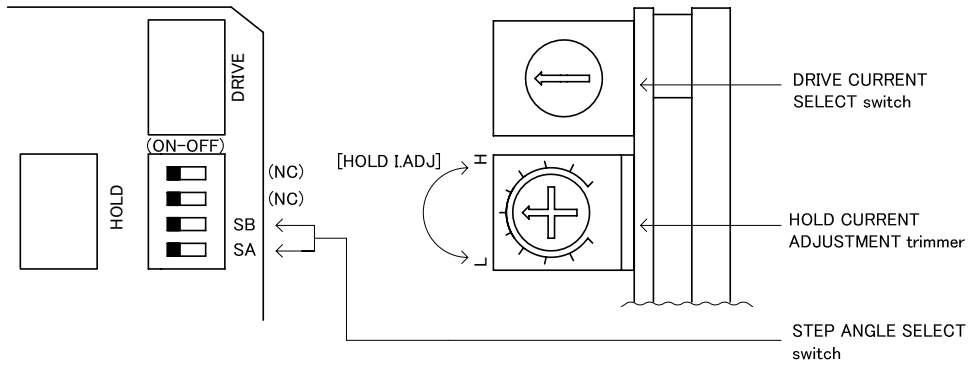

Name of Operation Section	Function	Factory Setting
DRIVE CURRENT SELECT switch	Selects DRIVE CURRENT.	[No. 6]
HOLD CURRENT ADJUSTMENT trimmer	Adjusts HOLD CURRENT.	[Approx. 40%]
STEP ANGLE SELECT switch	Selects a step angle.	SC : [1/1 division] SB : [ON] SA : [ON]

4. Function Set-up by Use

4 – 1. Setting STEP ANGLE SELECT switch

⚠ CAUTION

Erroneous setting may cause breakage of the machine or injury due to unexpected rotation of motor.
Ensure correct setting.

The step angle is set up with the STEP SEL switch.
The step angle can be selected from four different types of step angles.
Set this switch with power OFF.
The switches are factory-set to [1/1 divisions].

- (1) Turn power [OFF].
- (2) Set the STEP SEL switch [SA, SB] to the step angle required.

● Relationship between the STEP SEL switch and the step angle.

STEP SEL switch		Number of Divisions	Step angle(°)
SB	SA		1.8° motor
ON	ON	1/1	1.8
ON	OFF	1/2	0.9
OFF	ON	1/8	0.225
OFF	OFF	1/16	0.1125

(Factory setting)

4 – 2. Setting HOLD CURRENT ADJUSTMENT trimmer

⚠ CAUTION

A high setting value may cause burn on the skin due to overheating of the motor.
Do not select a high value beyond the required.

HOLD CURRENT is set up with the HOLD I.ADJ trimmer.
This sets the ratio of HOLD CURRENT to DRIVE CURRENT.
The trimmer is factory-set to approx. 40%.

(1) Set the gauge of the trimmer to the required value.

● Relationship between the trimmer scales and HOLD CURRENT.

$$\text{Ratio of HOLD CURRENT (\%)} = \frac{\text{HOLD CURRENT}}{\text{DRIVE CURRENT}} \times 100$$

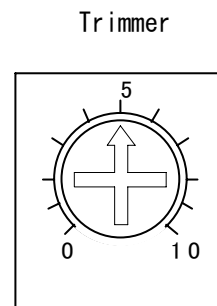
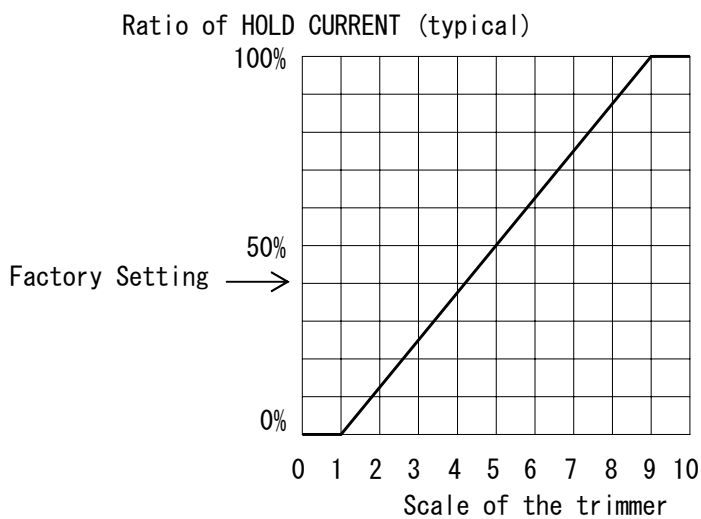

- HOLD CURRENT changes relative to DRIVE CURRENT setting.
The ratio of HOLD CURRENT of 100% represents the same as the setting for DRIVE CURRENT.
- The greater the ratio of HOLD CURRENT grows, the more heat the motor generates when is on holding-state.
- When the trimmer is set minimum, HOLD CURRENT is approx. 0.2A or less.

4 – 3. Setting DRIVE CURRENT SELECT switch

 CAUTION

Erroneous setting may cause burn on the skin due to overheating of the motor. Ensure correct setting.

DRIVE CURRENT is set up with the DRIVE I. SEL switch. The switch is factory-set to [No.6].

- (1) Set the switch No. to the setting specified in the table "10-5. Applicable Motors."

- Relationship between the DRIVE I. SEL switch and DRIVE CURRENT.

switch No.	DRIVE CURRENT A/phase
0	0.28
1	0.40
2	0.51
3	0.62
4	0.74
5	0.85
6	0.97
7	1.08
8	1.19
9	1.30
A	1.42
B	1.53
C	1.65
D	1.76
E	1.87
F	2.00

(Factory setting)

5. Installation

5-1. Conditions for Installation

⚠ WARNING

Overheating may cause fire.
Mount it on a noncombustible member.
Keep it away from combustibles.

- (1) Designed for incorporating into equipment used indoors, this product requires to be installed in the following environment:
- Indoors (where it is not exposed to direct sun).
 - Where ambient temperature and humidity are controlled within the range set out in the specifications.
 - Where there is no corrosive or inflammable gas.
 - Where it can be protected from dust, salt or iron powder.
 - Where the product main frame is not exposed to direct vibration or shock.
 - Where it is not exposed to splashes of water, oil or chemicals.
- (2) Install the driver at least 15mm away from other equipment.

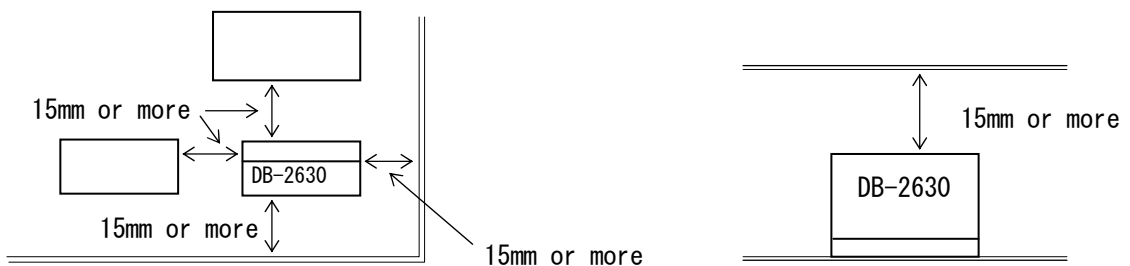

- (3) Considering heat release, control the ambient temperature around the driver within the specified value.
- Take measures against accumulation of heat such as allowing generous space around the driver or installing a fan so that heat release is taken care of.
 - Install the driver securely in contact with metal or other substance with adequate heat conductivity.
- (4) In the case that an overheat alarm(O. H. A) LED comes on, perform the cooling measure of the mounting plate is enlarged or compulsion air cooling etc.
Use the driver on the condition that an overheat alarm(O. H. A) LED goes out.
- (5) Do not allow standing or placing anything heavy on the product.

5 – 2. Mounting Method

The round holes on the main body are used.

The following items are required:

●M-3 screw (8mm or more in length):	2
●M-3 spring washer:	2
●M-3 flat washer:	2

(1) Fix the product at the two round holes on the main body.

●Mounting example

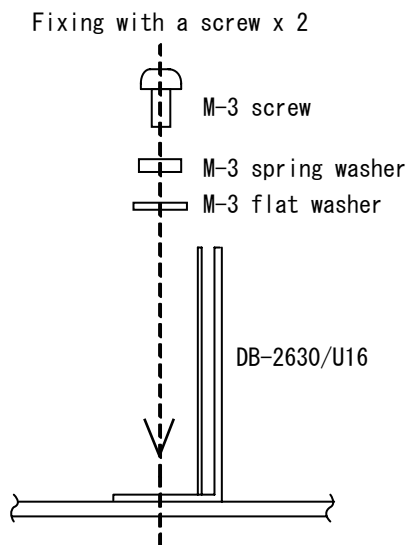

6. Connection

6-1. Overview of Connection Configuration

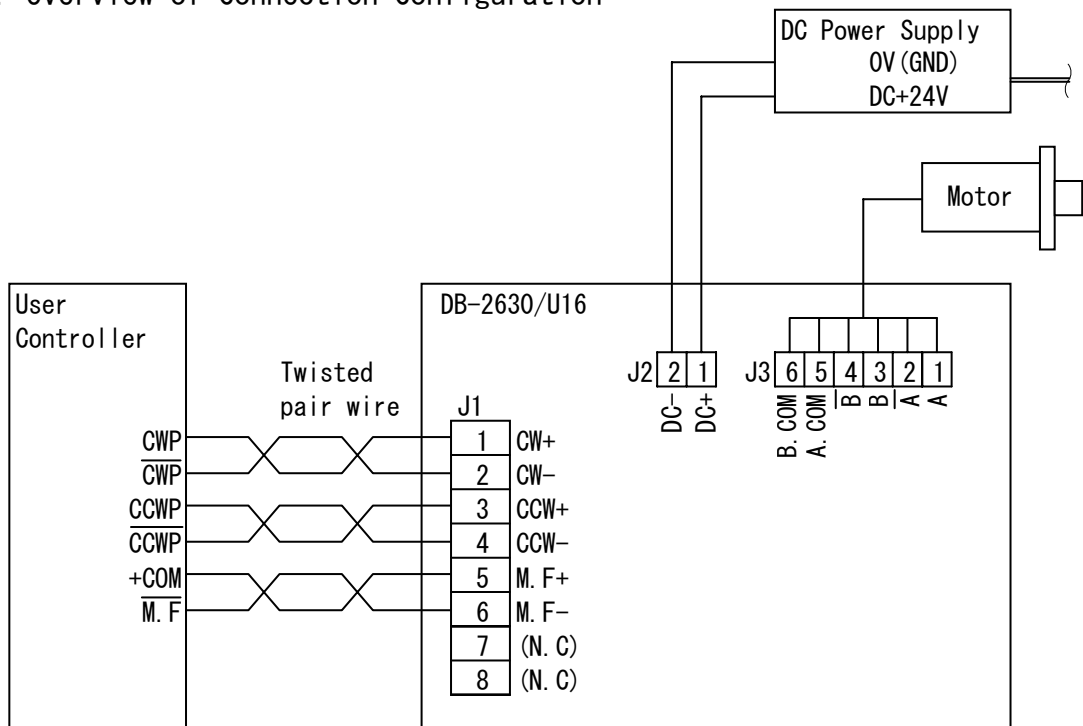

- Connect only one motor to one driver.
- Do not power ON/OFF by the relay etc. in the output side of the DC power supply.
- Use twisted pair wire for the CW/CCW input signal line.
- Provide shielding for the signal line where considerable noise is generated.
- Use the wire material of the characteristic that is difficult to burn.
- Provide shielding for the motor line if it generates significant noise.
- Use the DC power supply that was reinforced insulation between primary-side and secondary-side.

[Example configuration]

The metallic enclosure and shielded wires work to shield noise.

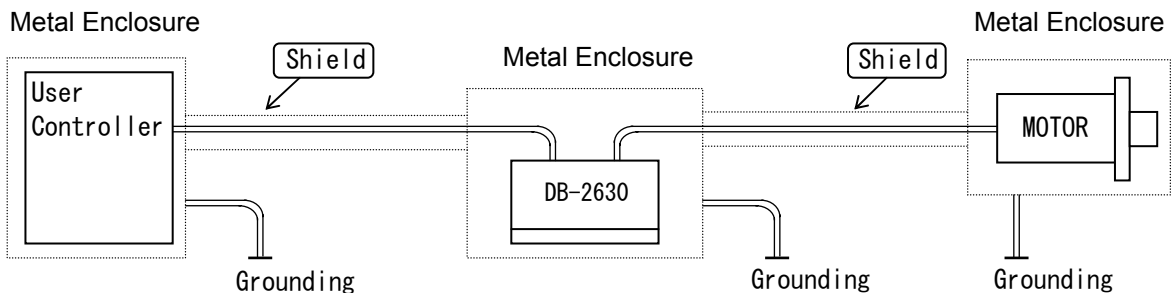

6-2. Connecting Signal I/O Connector (J1)

The following items are required:

- | | |
|-----------------------------------------------------------------|--------------------------|
| ●Housing for J1 (51103-0800:Molex) | One unit (accessory) |
| ●Contact for J1 (50351-8100:Molex) | 6 contacts (accessories) |
| ●Manually operated crimping tool for AWG28-22(57295-5000:Molex) | One unit |

- (1) Crimp the contact to the cable used for wiring.
- (2) Insert the contact into the housing.
Make sure that the housing No. and the connector No. on the main frame are matched before inserting the contacts.
- (3) Connect the housings to the connectors on the main frame.
 - The contacts for J1 are 6 pieces.
 - When inserting, keep pushing J1 housing into the connectors until it is locked. Also, check if the contacts are not displaced from the housing.
 - In wiring, isolate the J1 signal lines from equipment that may be a source of noise, the power line and the motor line.

(Surface on which the contacts are inserted)

Housing for J1

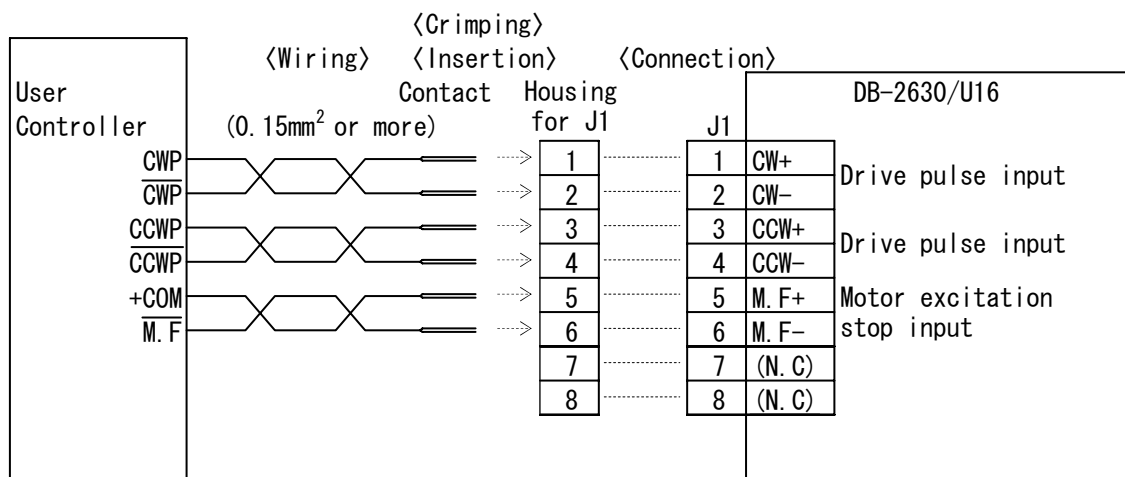
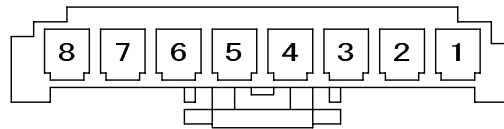

6 – 3. Connecting DC Input/Motor Output Connector (J 2 , J 3)

⚠ CAUTION

Erroneous connection may result in breakage of the motor or the driver. Correctly connect the motor wiring.

The following items are required:

- Housing for J2 (51067-0200:Molex) One unit (accessory)
- Housing for J3 (51067-0500:Molex) One unit (accessory)
- Contact (50217-9101:Molex) 8 contacts (accessories)
- Manually operated crimping tool One unit
for AWG24-18(57189-5000:Molex)

- (1) Crimp the contact to the cable used for wiring.
- (2) Insert the contact into the housing.
Make sure that the housing No. and the connector No. on the main frame are matched before inserting the contacts.
- (3) Connect the housings to the connectors on the main frame.
 - The contacts for J2(for DC input) are 2 pieces, and for J3(motor output) are 6 pieces.
 - When inserting, keep pushing J2, J3 housings into the connectors until it is locked. Also, check if the contacts are not displaced from the housing.

(Surface on which the contacts are inserted)

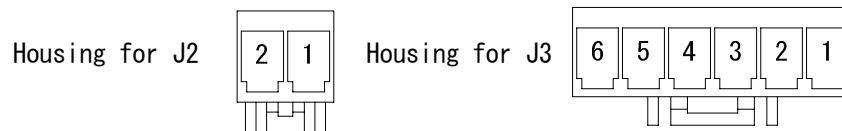

[DC input Connector]

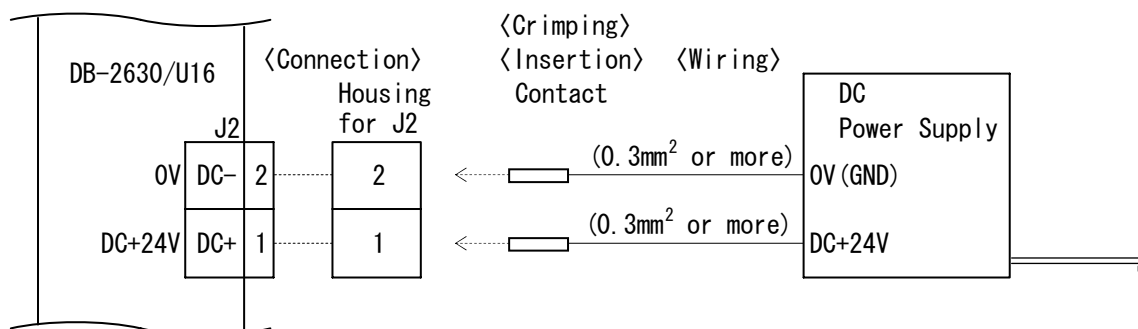

- Do not power ON/OFF by the relay etc. in the output side of the DC power supply.

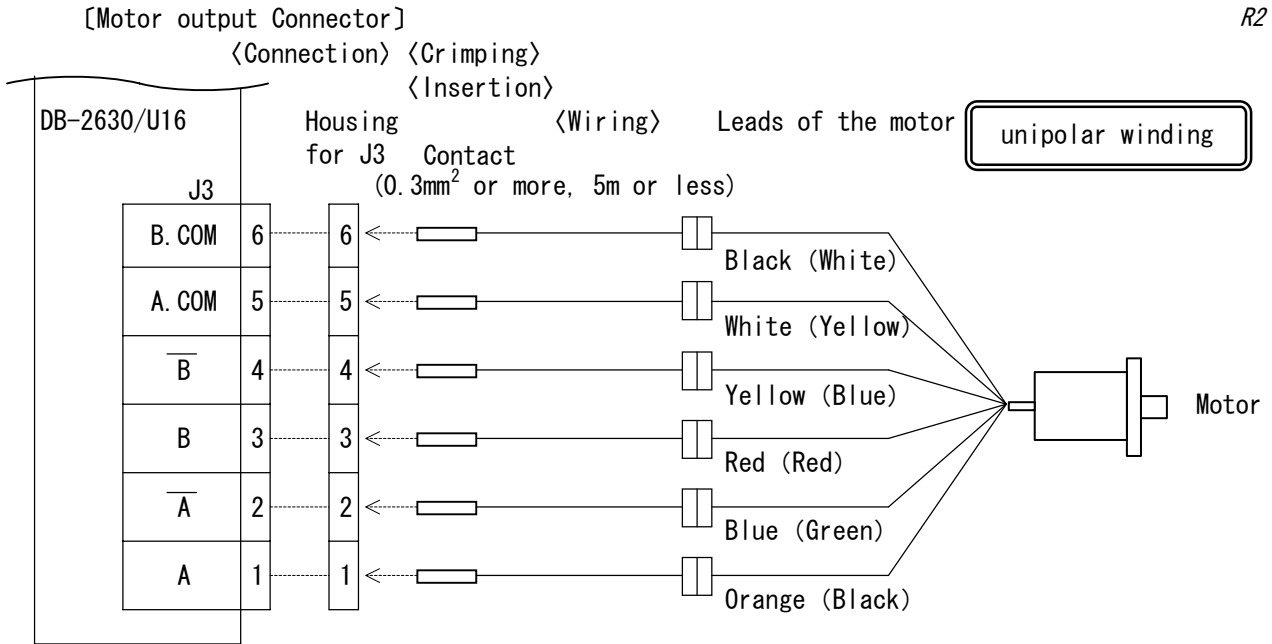

- Color indications for leads of the motor indicate motor of the SANYO DENK CO., LTD.. Color indications for leads of the motor () indicate motor of the ORIENTAL MOTOR CO., LTD..
- Black(White) line of motor to B.COM connector.
 White(Yellow) line of motor to B.COM connector.
 Separate Black(White) line and White(Yellow) line.
 Do not short circuit Black (White) line and White(Yellow) line.
 Doing so may result in breakage of the motor or the driver.
- Use a cable of 5m or less.

6 - 4. Inputting Power

CAUTION

Breakage of the machine or injury is apprehended due to unexpected behavior of the motor. Maintain the state where emergency stop is enabled at any time.

- (1) Input the DC power supply (DC+24V) in the cable that connected to No.1 and No. 2 terminals of J2.

7. Confirmation of Setting and Connection

7 – 1. Check Points

This product requires different switch setting and motor wiring depending on the motor used.

Check if the switch setting and the motor wiring are correctly performed.

Check Points		Check	Remarks
Setting of STEP ANGLE SELECT switch	STEP SEL (SA, SB)		
Setting of HOLD CURRENT ADJUSTMENT trimmer	Trimmer Scale		
Setting of DRIVE CURRENT SELECT switch	switch No.		
Connection of J1			
Connection of J2	DC+, DC-		
Connection of J3	MOTOR		

8. Maintenance and Check-up

8 – 1. Maintenance and Check-up

⚠ WARNING

Injury or fire is apprehended due to unexpected behavior.
Do not replace fuse.
Do not disassemble, repair or modify.

- (1) As for a maintenance inspection the engineer of the specialty shall do it.
- (2) We recommend that the following check-ups should be performed periodically:
 - Checking for any loosened contact on the connectors.
 - Checking for any flaw and crack on the cabling.
- (3) In case of failure, return the driver to us and have it repaired.

8 – 2. Troubleshooting

R2

Trouble	Check Item	Assumed Cause
1. POWER LED does not come on.	<ul style="list-style-type: none"> ▪ Connection of power supply. ▪ Value of power voltage. 	<ul style="list-style-type: none"> ▪ Wiring error with power supply. ▪ Power voltage failure. ▪ Driver failure.
2. The motor is not excited. (It can be easily rotated by hand.)	<ul style="list-style-type: none"> ▪ Connection of the motor to the driver. ▪ ON/OFF status of the M.F signal. ▪ Value of the HOLD CURRENT ADJUSTMENT trimmer. 	<ul style="list-style-type: none"> ▪ Wiring error with the motor and the driver. ▪ The M.F signal is input. ▪ HOLD CURRENT is set to zero. ▪ Driver failure.
3. The motor does not rotate. The motor behaves abnormally. The motor steps out.	<ul style="list-style-type: none"> ▪ The same check items as those under item 2 above. ▪ Connection of the pulse signal. ▪ Voltage and wave form of the pulse signal. ▪ Setting of the DRIVE CURRENT SELECT switch. ▪ Setting of the STEP ANGLE SELECT switch. 	<ul style="list-style-type: none"> ▪ Wiring error with the pulse signal line. ▪ Pulse signal of wrong specifications. ▪ DRIVE CURRENT is too low. ▪ Wrong setting for the step angle. ▪ Driver failure. ▪ Motor failure.
4. The motor steps out during acceleration.	<ul style="list-style-type: none"> ▪ Starting pulse speed. ▪ Acceleration time. 	<ul style="list-style-type: none"> ▪ Starting pulse signal speed is too high. ▪ Acceleration time is too short.
5. The motor generates excessive heat.	<ul style="list-style-type: none"> ▪ Setting of the DRIVE CURRENT SELECT switch. ▪ Value of the HOLD CURRENT ADJUSTMENT trimmer. 	<ul style="list-style-type: none"> ▪ DRIVE CURRENT is higher than the setting for the applicable motor. ▪ The setting for HOLD CURRENT is too high.

Short-circuiting of the motor output connector may cause the driver to fail.

- The motor output connector and the power line.
- The motor output connector and the motor output connector.
- A.COM line and B.COM line.

Disconnection of the motor output line may cause the driver to fail.

- Disconnection of the motor output line cable.
- Loose connection of connector.

When the failure phenomenon cannot be remedied, contact our office.

9. Storing and Disposal

9 – 1. Storing

(1) Keep the product in the following environment:

- Indoors (where it is not exposed to direct sun).
- Where ambient temperature and humidity are controlled within the range set out in the specifications.
- Where there is no corrosive or inflammable gas.
- Where it can be protected from dust, salt or iron powder.
- Where the product main frame is not exposed to direct vibration or shock.
- Where it is not exposed to splashes of water, oil or chemicals.

(2) Do not allow standing or placing anything heavy on the product.

9 – 2. Disposal

(1) Dispose of the product as industrial waste.

1 0. Specifications

R2

1 0 – 1. General Specifications

Supply Power	DC+24V *1 (Ripple voltage P-P 2.0V or less) ●Rated input current : [DRIVE I. SEL ⇒ No. F set up] at DRIVE DC+24V: 2.5A *2 ●Rated input current : [HOLD I. ADJ ⇒ Approx. 40% set up] at HOLD DC+24V: 0.6A	
Motor output current	●DRIVE CURRENT 0.28A/phase~2.0A/phase ●HOLD CURRENT Approx. 40% of DRIVE CURRENT (factory-set)	
Input Signal	●Drive pulse input (CW, CCW) ----- Photo-coupler input ●Motor excitation stop input (M.F) ----- Photo-coupler input	
Functions of Operating Sections	●DRIVE CURRENT selection (DRIVE I. SEL) ●HOLD CURRENT adjustment (HOLD I. ADJ) ●Step angle selection (STEP SEL)	
Overheat alarm	●Overheat alarm LED (O. H. A LED)	
Operating Ambient Temperature	0°C ~ +40°C (No freezing allowed.)	
Operating Ambient Humidity	80%RH or less (No condensation allowed.)	
Storing Temperature	-10°C ~ +55°C (No freezing allowed.)	
Storing Humidity	80%RH or less (No condensation allowed.)	
Atmosphere	Indoor (Exposure to direct sun is not allowed.) Without any corrosive or inflammable gas, oil mist, or dust.	
Withstanding Vibration	No abnormality should be found after a vibration test at 10~55Hz, 0.15mm P-P	
Insulation resistance	DC connector - signal connector - Frame (Each other)	DC500V 100MΩ or more
Exterior Dimensions	$H66 \times W71 \times D35$ (mm)	
Weight	0.1 kg	

*1 Input voltage range is DC+24V±10%.

*2 Use a power supply that provides sufficient input current.

10-2. I/O Signal

(1) Example Circuit Connection

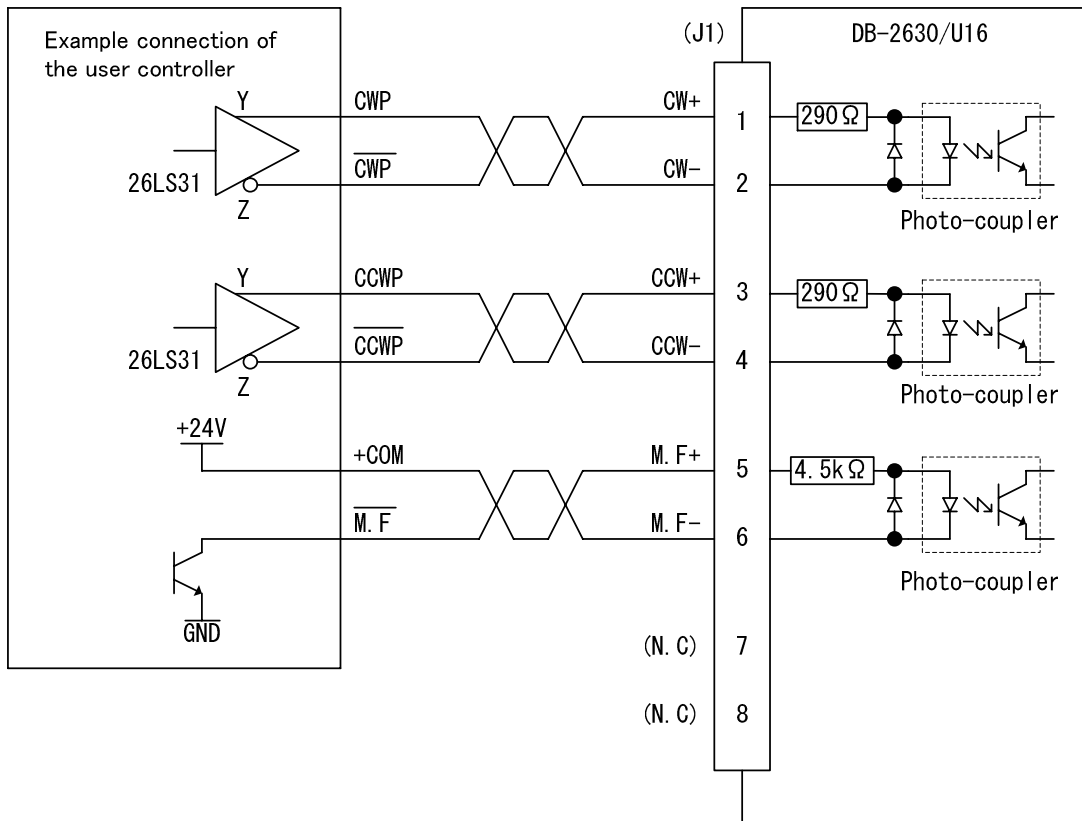

(2) Drive pulse input (CW, CCW)

- ① Operating current range : 6.9mA~16.4mA
 The photo-coupler turns on with inter-terminal voltage of 3.1 V~5.4 V.
 (Photo-coupler diode $V_F \doteq 1.1$ V)

② Timing chart

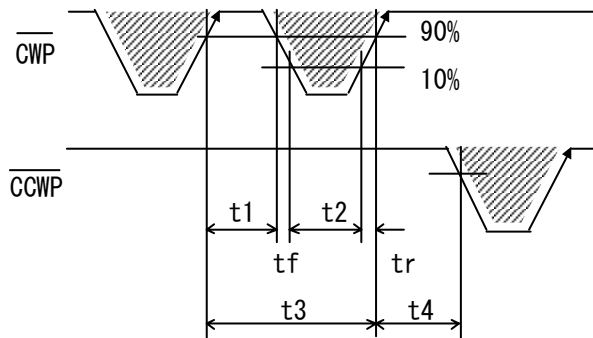

$t_1 \geq 7.1 \mu s$, $t_2 \geq 7.1 \mu s$, $t_f, t_r \leq 2 \mu s$
 $t_3 > 14.3 \mu s$, $t_4 > 1ms$

Maximum response frequency : 70kHz

- The shaded area () indicates light emission from the photo-coupler, and the motor is driven at the rising edge ().
 "t4" greatly varies according to the inertial moment including that of the motor.

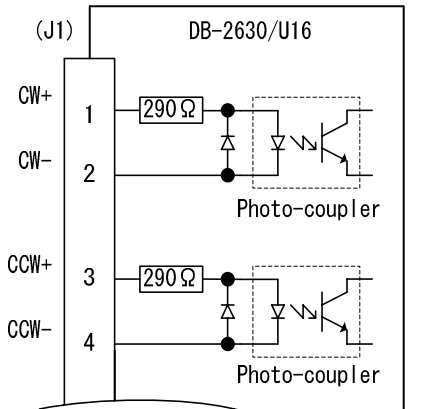

[To the line driver 26LS31]

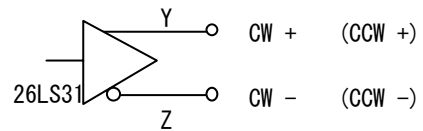

③ Automatic switching for DRIVE/HOLD

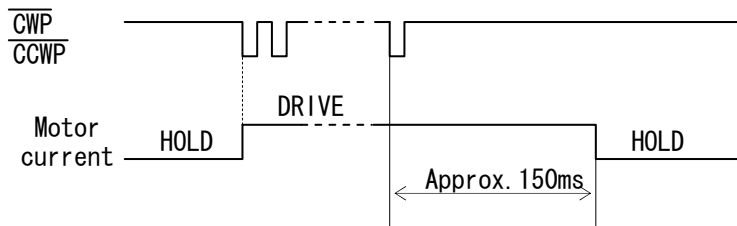

- Inputting drive pulse causes the current output to the motor to change from HOLD CURRENT to DRIVE CURRENT, which returns to HOLD CURRENT in about "Approx. 150ms". DRIVE CURRENT continues if pulse is input on driving-state.

④ Direction of rotation

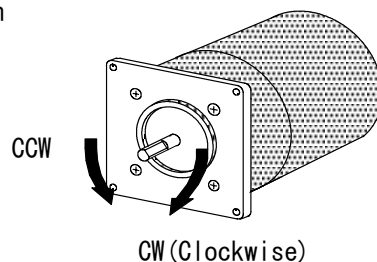

(3) Motor excitation stop input (M.F)

CAUTION

Deterioration of the holding power with the motor may cause breakage of the machine or injury.
Check safety before inputting.

- ① Operating current range : 4mA~5.3mA
The photo-coupler turns on with inter-terminal voltage of 19.1 V~25.1 V.
(Photo-coupler diode $V_F \doteq 1.1$ V)

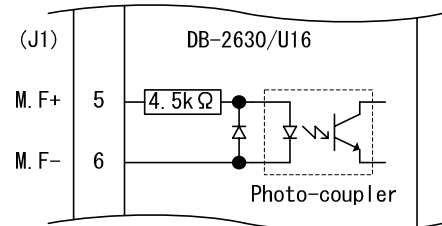

- Motor output current is shut off with the photo-coupler ON.
At this time, motor torque changes to detent torque.
- When this signal is input, motor torque may be lost, resulting in failure to retain the load transported.
In particular, this risk is high with the vertical drive (such as the Z-axis).

② Timing chart

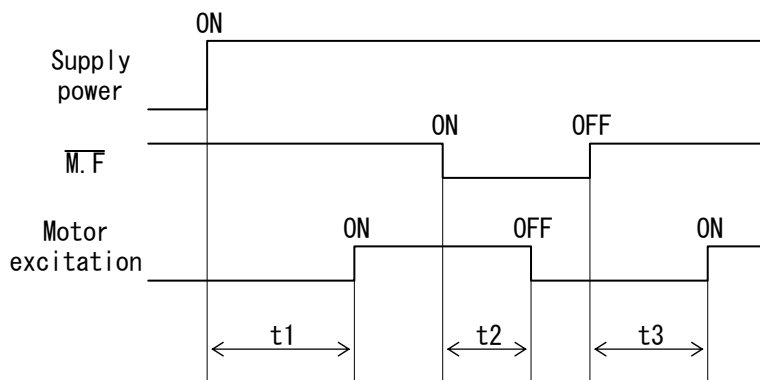

- $t1 \leq 300\text{ms}$ ($t1$: Time required for the motor to be enabled.)
- $t2 \leq 5\text{ms}$ ($t2$: Time required for the motor output current to be shut off.)
- $t3 \leq 100\text{ms}$ ($t3$: Time required for the motor to be enabled.)

1 0 – 3. Overheat alarm (O. H. A) LED

 **WARNING**

Overheating may cause fire.
Stop operation upon output of this signal.

- In case of internal temperature of the driver reaches approx. 70°C or more, O.H.A LED comes on. At this time the motor output current is not blocked.
- When this LED comes on, stop operation and check if there is any abnormality occurring with the motor and the driver.
- Provide mechanical cooling, for example, if this LED comes on while no abnormality is detected.
- Continuous operation is possible unless this LED comes on.

1 0 - 4. Dimensions

(Unit : mm)

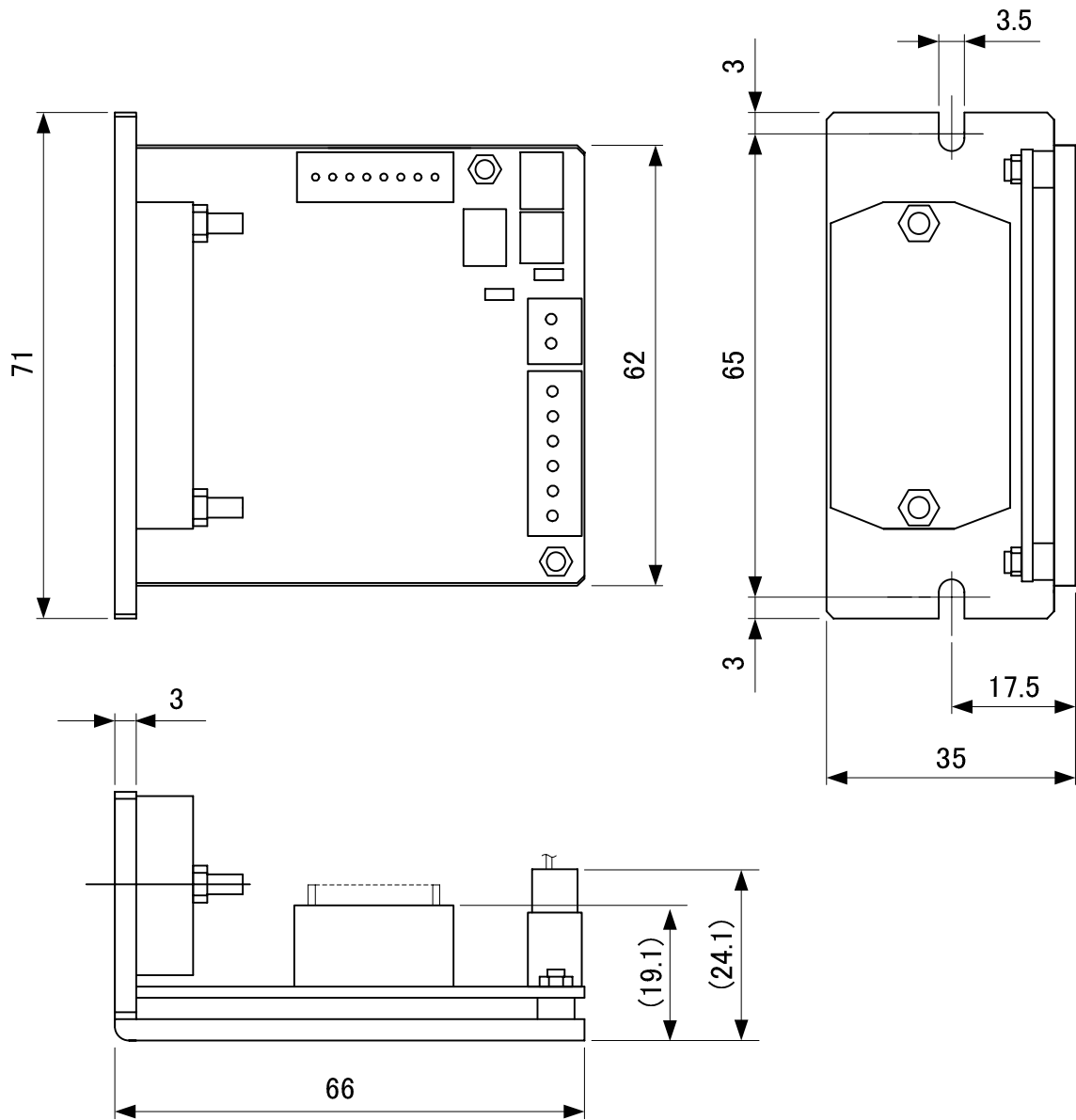

1 0 – 5. Applicable Motors

- Applicable motors are 2-phase stepping motor of unipolar winding ranging from 0.4A/phase ~ 2.0A/phase.

Applicable Motors	Basic Angle (°)	Current (A/phase)	DRIVE I. SEL	Torque Data Fig. No.
SANYO DENKI CO., LTD.				
103H7121-0140 (0110) 103H7123-0140 (0110) 103H7126-0140 (0110)	1.8	1.0	6	Fig. 1 Fig. 2 Fig. 3
103H7121-0440 (0410) 103H7123-0440 (0410) 103H7126-0440 (0410)	1.8	2.0	F	Fig. 4 Fig. 5 Fig. 6
ORIENTAL MOTOR CO., LTD.				
PK243-01A (B)	1.8	0.95	6	Fig. 7
PK264-01A (B) PK266-01A (B) PK268-01A (B)	1.8	1.0	6	Fig. 8 Fig. 9 Fig. 10
PK244-01A (B) PK245-01A (B)	1.8	1.2	8	Fig. 11 Fig. 12
PK264-02A (B) PK266-02A (B) PK268-02A (B)	1.8	2.0	F	Fig. 13 Fig. 14 Fig. 15
Factory Setting			6	—

() : Both axes

1 0 – 6. Torque Characteristics

R2

- (1) Representations in the torque characteristics table are made in terms of the motor rotation (s^{-1}) vs. torque ($N \cdot m$).

Motor rotation (s^{-1}) and drive pulse frequency (Hz) are converted as follows:

$$\text{Motor rotation}(s^{-1}) \times \frac{360^{\circ}}{\text{Step angle}} = \text{Drive pulse input frequency(Hz)}$$

- (2) The Maximum Starting Pulse Rate is represented as "fs" by the value at zero inertial load.
- (3) Upon operation, provide adequate allowance for torque.
- (4) The stepping motor may attain high temperature, depending on the operational conditions.
If the surface temperature exceeds 100°C , provide cooling measures to control it to operate at 100°C at the highest.

Fig. 1

103H7121-0140 (0110)
1.0A/PHASE

DRIVE I. SEL = No. 6
DC24V

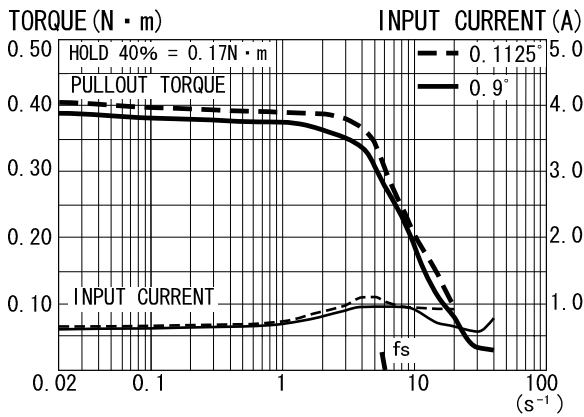

Fig. 2

103H7123-0140 (0110)
1.0A/PHASE

DRIVE I. SEL = No. 6
DC24V

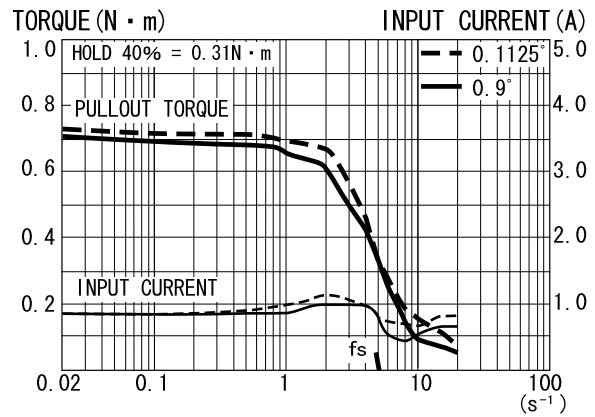

Fig. 3

103H7126-0140 (0110)
1.0A/PHASE

DRIVE I. SEL = No. 6
DC24V

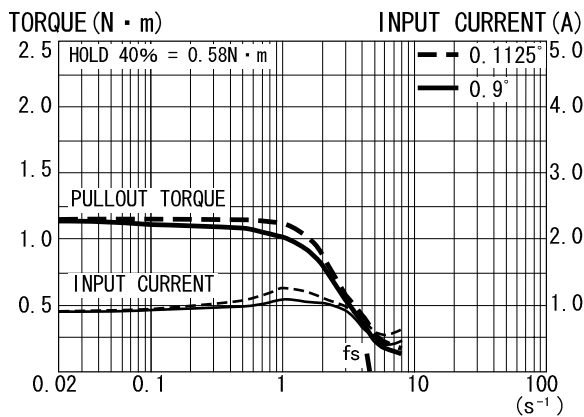

Fig. 4

103H7121-0440 (0410)
2.0A/PHASE

DRIVE I. SEL = No. F
DC24V

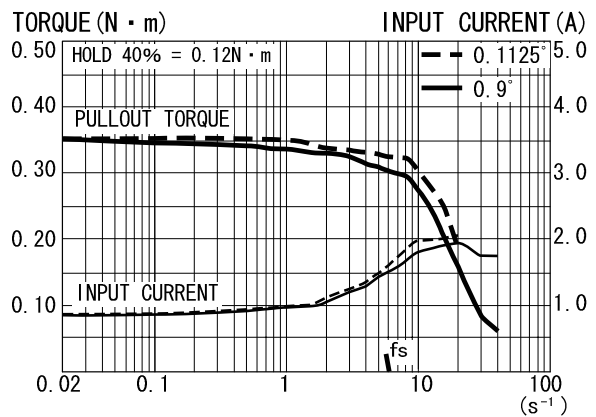

Fig. 5

103H7123-0440 (0410)
2.0A/PHASE

DRIVE I. SEL = No. F
DC24V

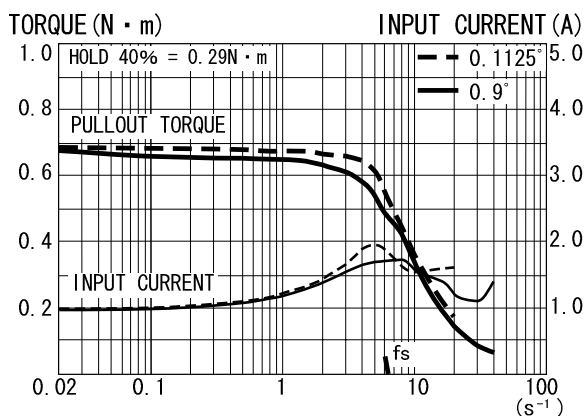

Fig. 6

103H7126-0440 (0410)
2.0A/PHASE

DRIVE I. SEL = No. F
DC24V

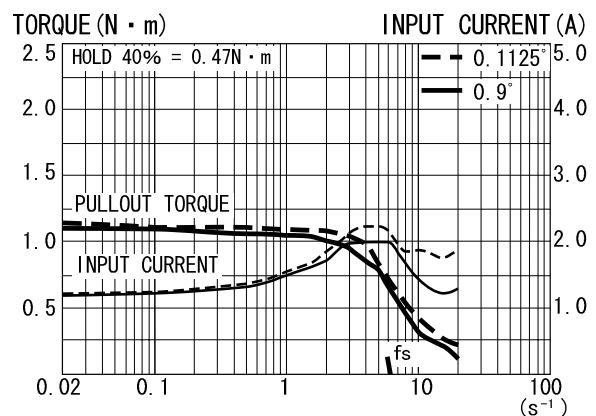

Fig. 7

PK243-01A(B)
0.95A/PHASE

DRIVE I. SEL = No. 6
DC24V

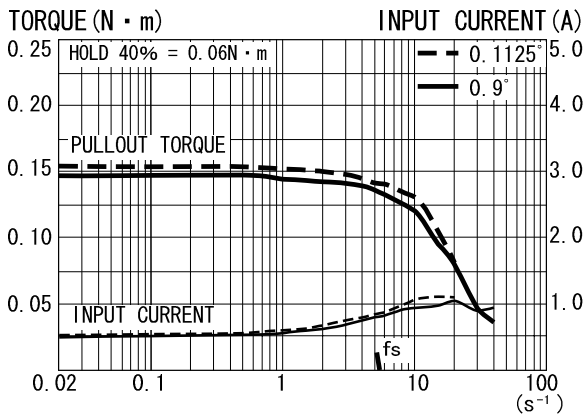

Fig. 8

PK264-01A(B)
1.0A/PHASE

DRIVE I. SEL = No. 6
DC24V

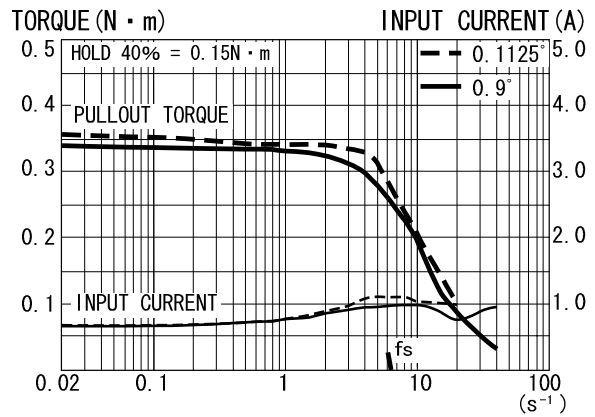

Fig. 9

PK266-01A(B)
1.0A/PHASE

DRIVE I. SEL = No. 6
DC24V

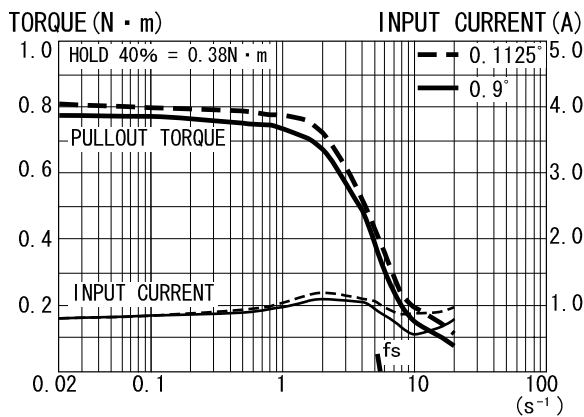

Fig. 10

PK268-01A(B)
1.0A/PHASE

DRIVE I. SEL = No. 6
DC24V

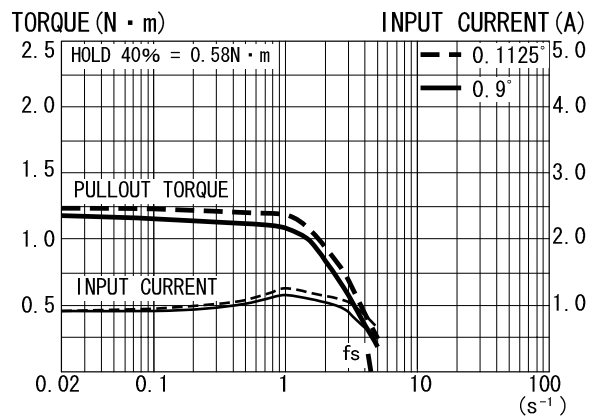

Fig. 11

PK244-01A(B)
1.2A/PHASE

DRIVE I. SEL = No. 8
DC24V

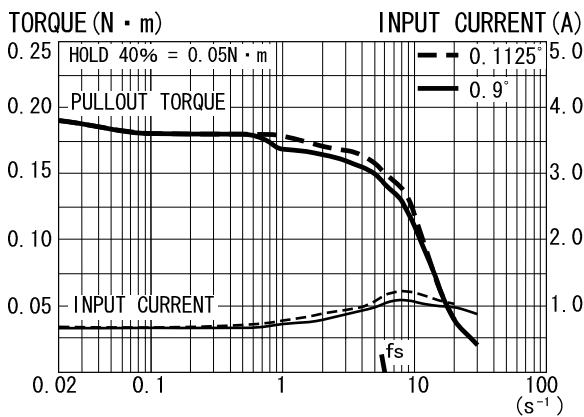

Fig. 12

PK245-01A(B)
1.2A/PHASE

DRIVE I. SEL = No. 8
DC24V

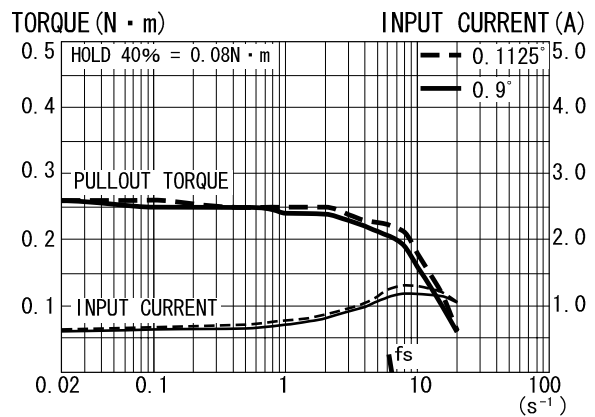

Fig. 13

PK264-02A (B)
2.0A/PHASE

DRIVE I. SEL = No. F
DC24V

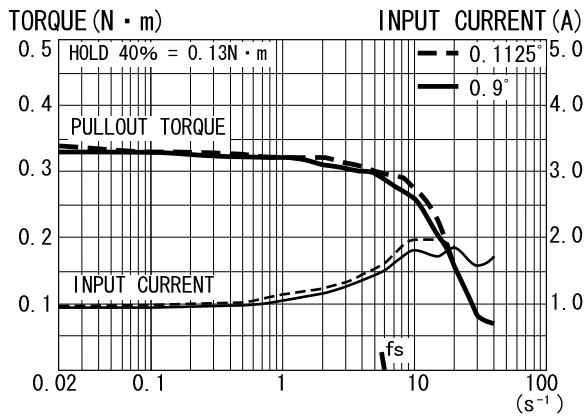

Fig. 14

PK266-02A (B)
2.0A/PHASE

DRIVE I. SEL = No. F
DC24V

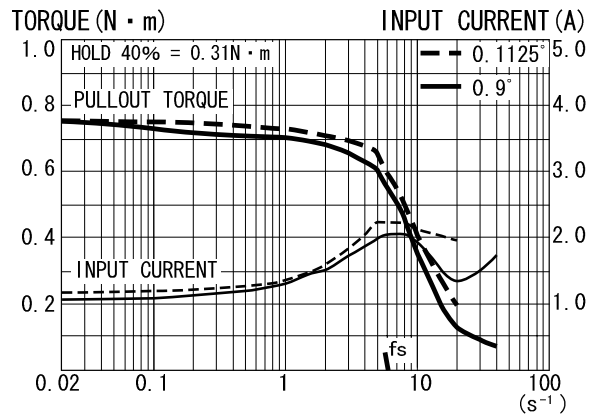
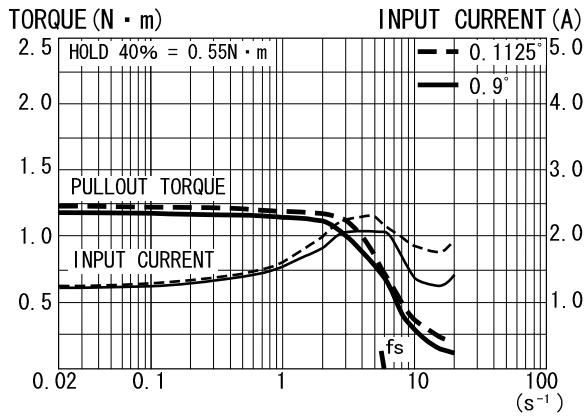

Fig. 15

PK268-02A (B)
2.0A/PHASE

DRIVE I. SEL = No. F
DC24V



Technical Service

TEL. (042) 664-5382 FAX. (042) 666-5664
E-mail s-support@melec-inc.com

Sales and Service

TEL. (042) 664-5384 FAX. (042) 666-2031
URL:<http://www.melec-inc.com>

Melec Inc. Control equipment marketing department
516-10, Higashiasakawa-cho, Hachioji-shi, Tokyo 193-0834, Japan

This Operating Manual is subject to change without prior notice
for the purpose of product improvement.